

DATE
Sept. 6, 2011
CAT. #: CD0206-50

OUTLINE DIMENSIONS
3-PHASE INDUCTION MOTOR

MOTOR TYPE:
AEEAGD
FRAME NO. 286T

Pole	HP	kW	Hz	VOLT	Syn. Speed r/min(rpm)
6	20	15	50	190/380	1000

Ins	Rating	Dimension in	Approx Weight	Bearings
F	CONT.	inches	458 lbs.	DE: 6311ZZ NDE: 6310ZZ

Totally Enclosed Fan-Cooled Type. Squirrel-Cage Rotor.

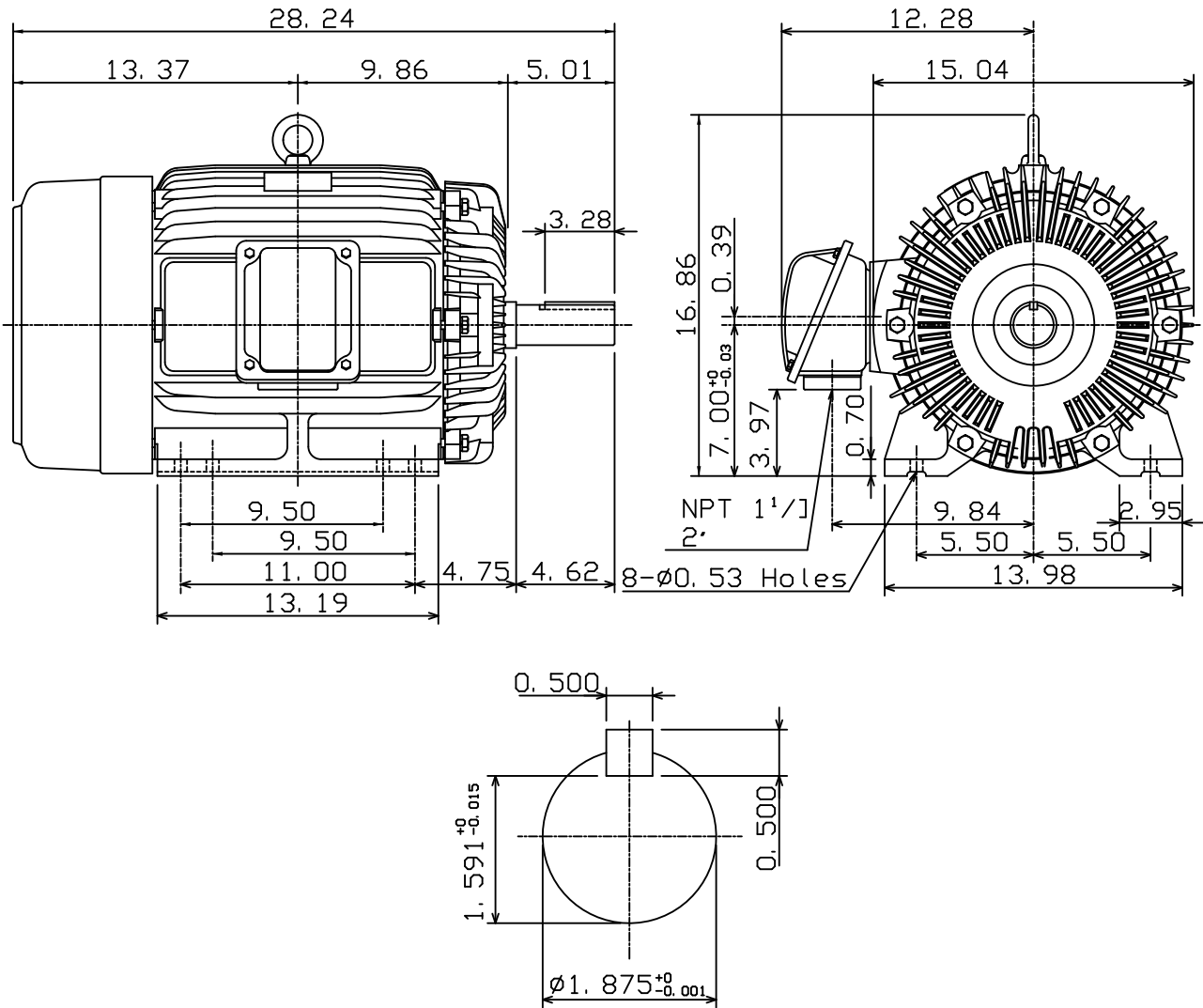

DWN.	K. L. KUO	01-01-05
CHKD.	C. H. KAO	01-28-05
APPD.	M. C. TSAI	01-28-05

TEC   Westinghouse

DWG NO.
31057H212420