

CATALOG NO. CD0304	OUTLINE DIMENSIONS 3-PHASE INDUCTION MOTOR	MOTOR TYPE: AEEAGD
DATE JULY-20-15		FRAME NO. 286T

Pole	HP	kW	Hz	VOLT	r/min(rpm)
4	30	22	60	230/460	1800

Ins	Rating	Dimension in	Approx Weight	Bearings	
F	CONT.	inches	445 lbs.	DE: 6311Z	NDE: 6310Z

Totally Enclosed Fan-Cooled Type, Squirrel-cage Rotor.

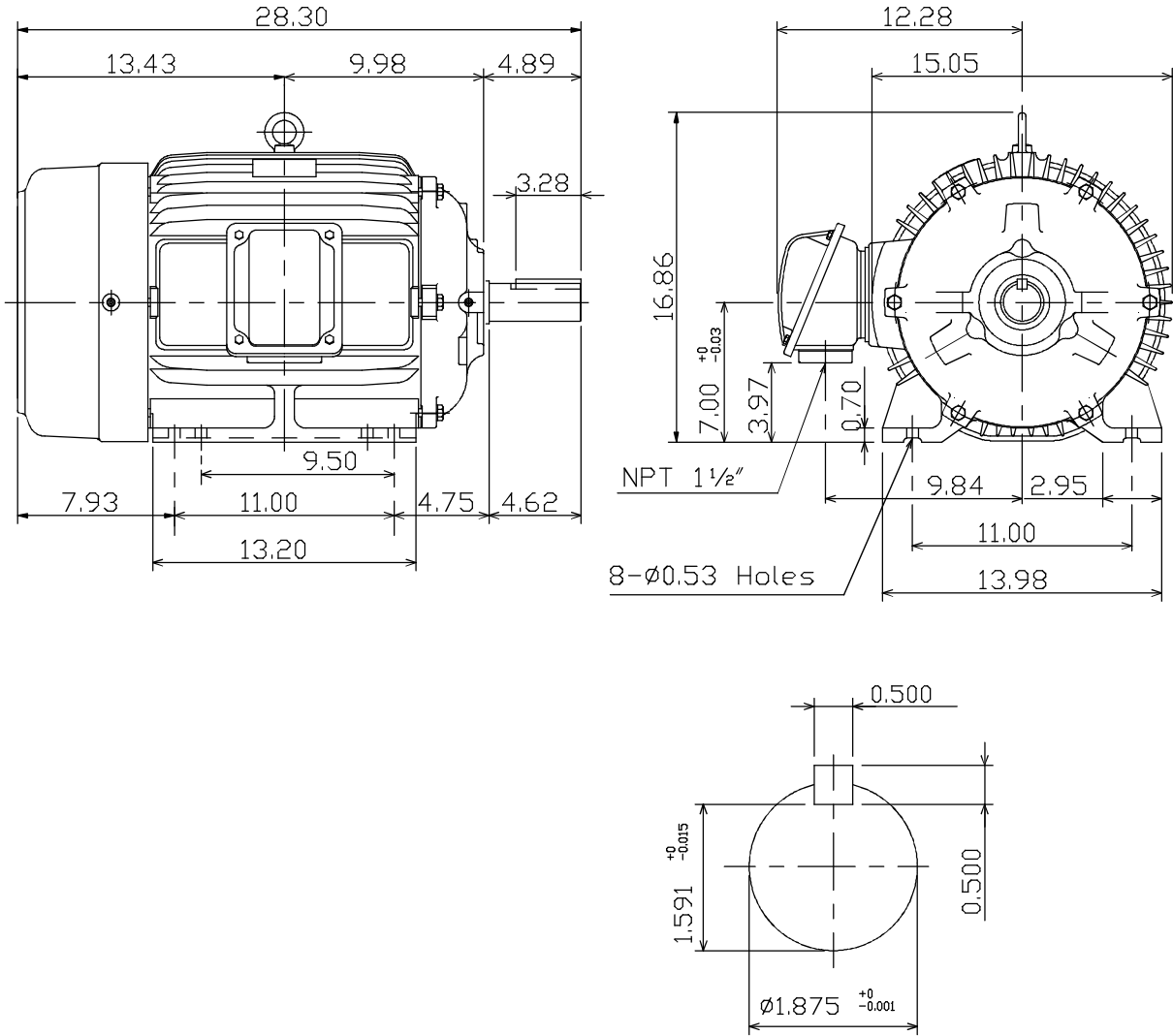

- NOTE:
1. ENCLOSURE: IP55
 2. SHAFT MATERIAL: SCM440 Q&T (AISI 4140 EQUIV)
 3. WITH THERMISTOR: PTC 140°C x 3PCS
WIRED IN MAIN TERMINAL BOX

TW-26C

	DWG. C. RAM	07 20 15
--	-------------	----------

DWG.	W.J.HUANG	06.18.13	TEC Westinghouse	DWG NO.
CHKD.	K.L.KUD	06.20.13		31057H212590
APPD.	C.H.SHYU	06.20.13		