

DATE
SEPT. 13, 2011
CATALOG NO.
CDO604-50

OUTLINE DIMENSIONS
3-PHASE INDUCTION MOTOR

MOTOR TYPE:
AEEAGD
FRAME NO. 364T

Pole	HP	kW	Hz	VOLT	Syn. Speed r/min(rpm)
4	60	45	50	190/380	1500

Ins	Rating	Dimension in	Approx Weight	Bearings
F	CONT.	inches	772 lbs.	DE: 6313 NDE: 6213

Totally Enclosed Fan-Cooled Type. Squirrel-Cage Rotor.

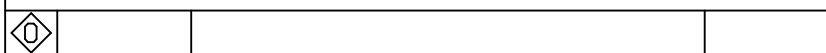
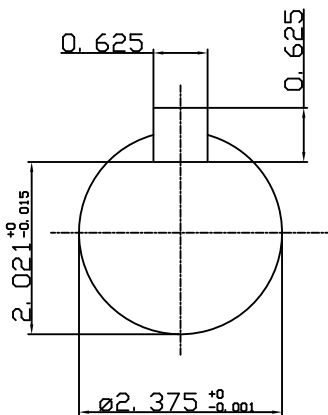
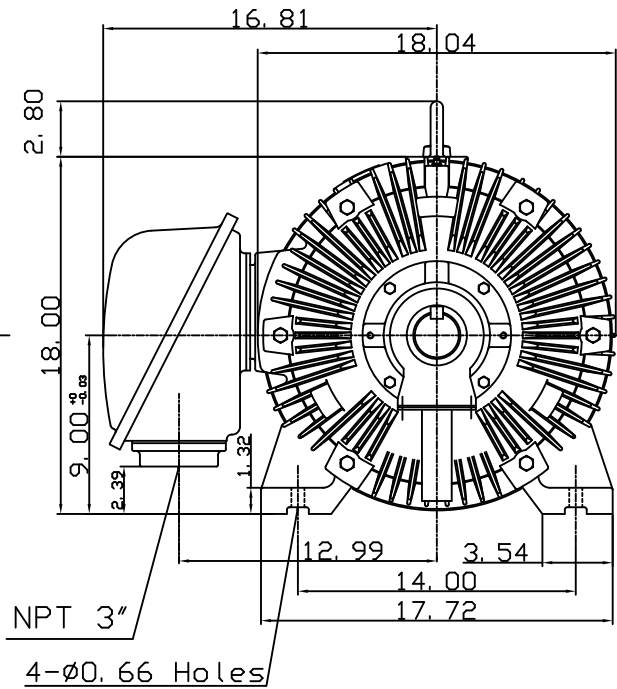
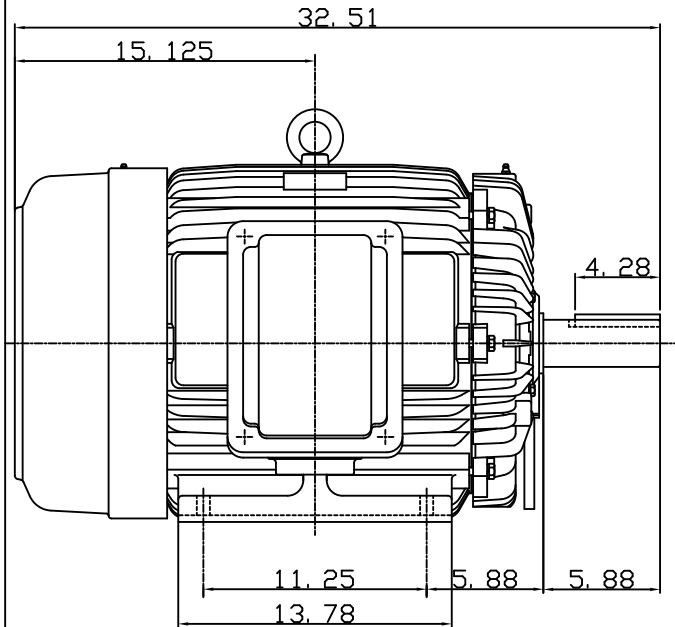

DWN.	S. M. JEAN	05-22-04
CHKD.	C. H. SHYU	05-22-04
APPD.	M. C. TSAI	05-22-04

TECO  **Westinghouse**

DWG NO.
31049U519061