

CATALOG NO. CD0604		OUTLINE DIMENSIONS 3-PHASE INDUCTION MOTOR		MOTOR TYPE: AEEAGD	
DATE JULY-20-15				FRAME NO. 364T	

Pole	HP	kW	Hz	VOLT	r/min(rpm)
4	60	45	60	230/460	1800

Ins	Rating	Dimension in	Approx Weight	Bearings	
F	CONT.	inches	718 lbs.	DE: 6313	NDE: 6213

Totally Enclosed Fan-Cooled Type, Squirrel-Cage Rotor.

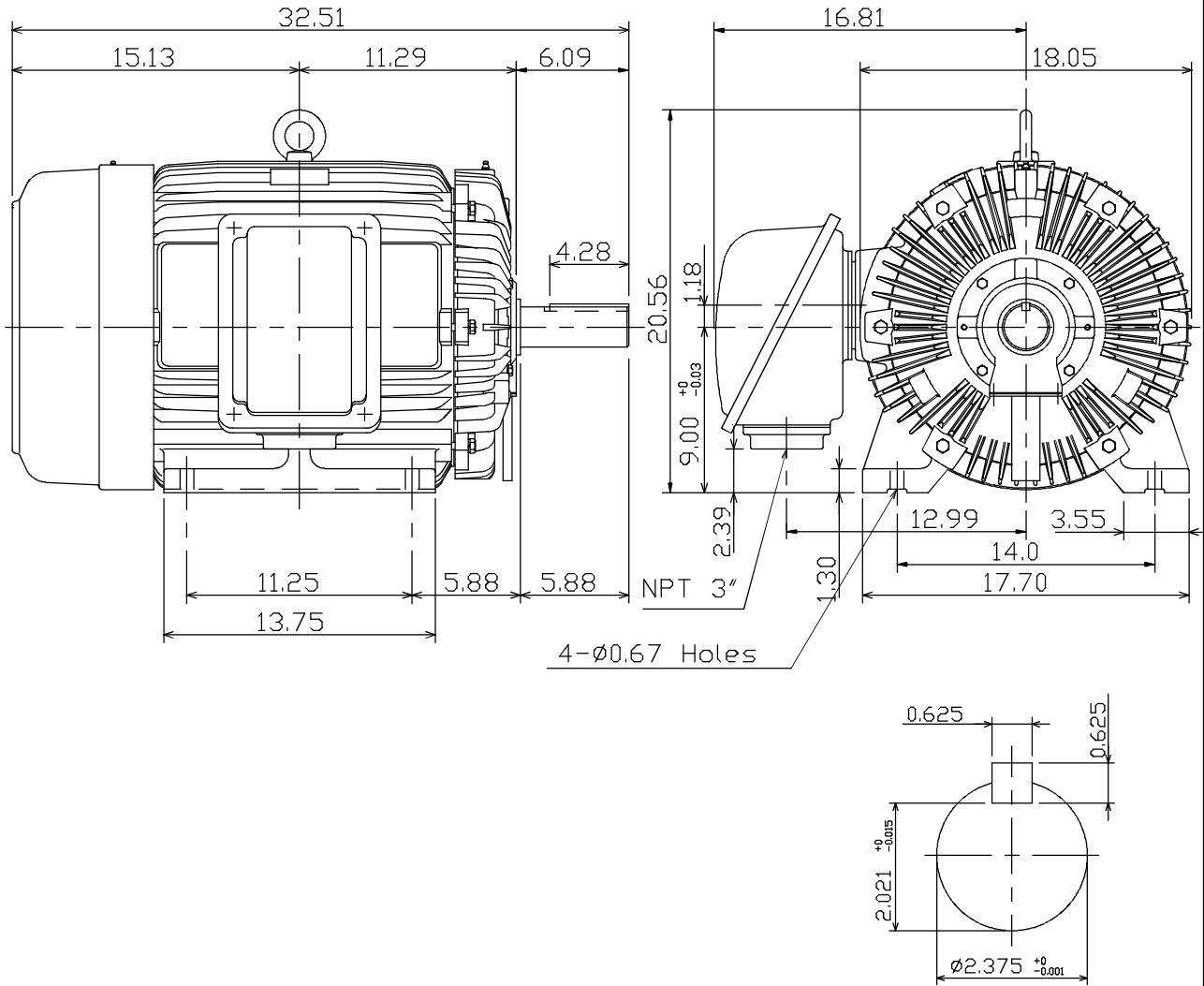

- NOTE:
1. ENCLOSURE: IP55
  2. SHAFT MATERIAL: SCM440 Q&T (AISI 4140 EQUIV)
  3. WITH THERMISTOR: PTC 140°C × 3PCS  
WIRED IN MAIN TERMINAL BOX

TW-46C

◇	DWG. C. RAM	07 20 15
---	-------------	----------

DWG.	J.S.LIN	06.15.13	TEC   Westinghouse	DWG NO.	31049J361610
CHKD.	K.L.KUD	06.15.13			
APPD.	C.H.SHYU	06.15.13			