

TYPE	OUTPUT		POLE	TIME RATING	VOLTAGE V	Hz	SYN. SPEED R. P. M
	HP.	kW.					
AEHH-GD	250	187	8	CONT.	460	60	900

TOTALLY ENCLOSED FAN-COOLED TYPE, SQUIRREL-CAGE ROTOR

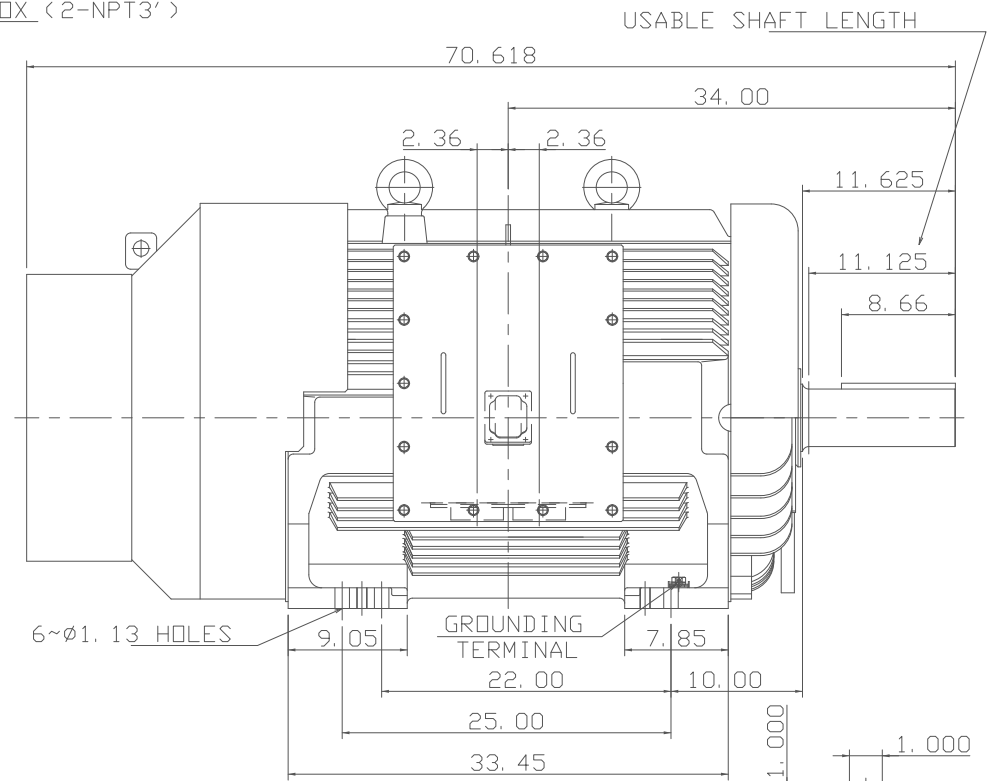
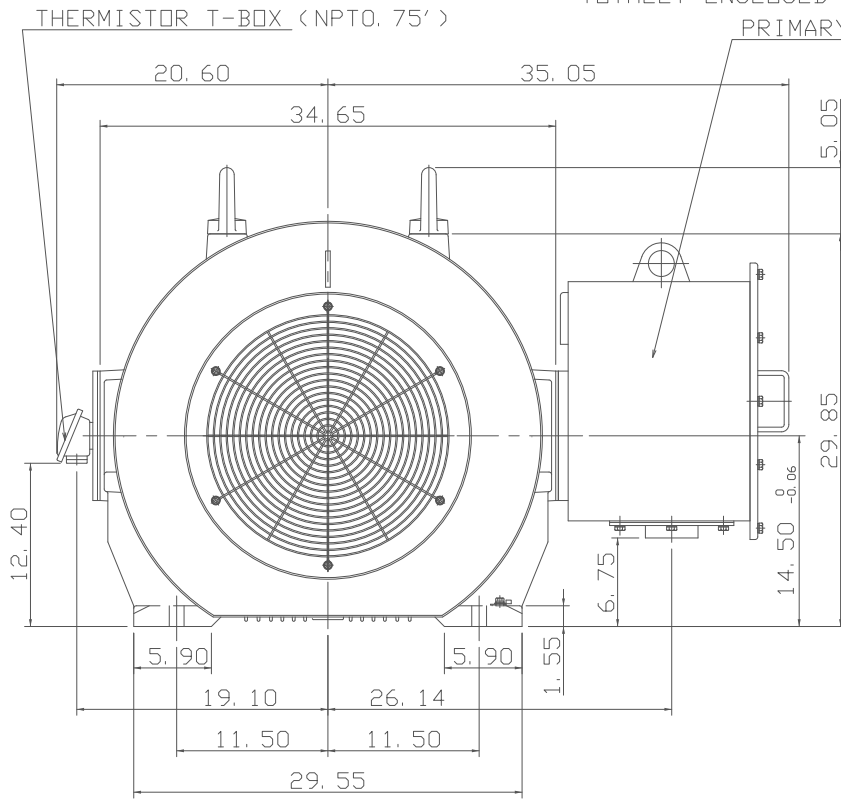

SHAFT END
(ENLARGED VIEW)

NOTE:

1. DIMENSIONS IN inch
2. FRAME NO.586/7UZ
3. F CLASS INSULATION, S. F. 1. 15
4. FOR BELT DRIVE
5. ENCLOSURE: IP55
6. BEARING SIZE: DRIVE-END NU326C3
OPP. DRIVE-END 6322
7. NON-SPARKING FAN
8. WITH THERMISTOR: PTC 140°C 3PCS
9. MOTOR APPROX. WEIGHT: 4610lb

DATE
April 30, 2018
CATALOG NO.
CDP2508RZ

OUTLINE DIMENSIONS
3-PHASE INDUCTION MOTOR

DWN.	J. WANG	MAR·10·2017
CHKD.	H. HUANG	MAR·10·2017
APPD.	C. LIU	MAR·10·2017

TEC Westinghouse

DWG NO. REV: 02
4B040T894