

TYPE	OUTPUT		POLE	TIME RATING	VOLTAGE V	Hz	SYN. SPEED R. P. M
	HP.	kW.					
AFHH			8	CONT.			

TOTALLY ENCLOSED FAN-COOLED TYPE. SQUIRREL-CAGE ROTOR

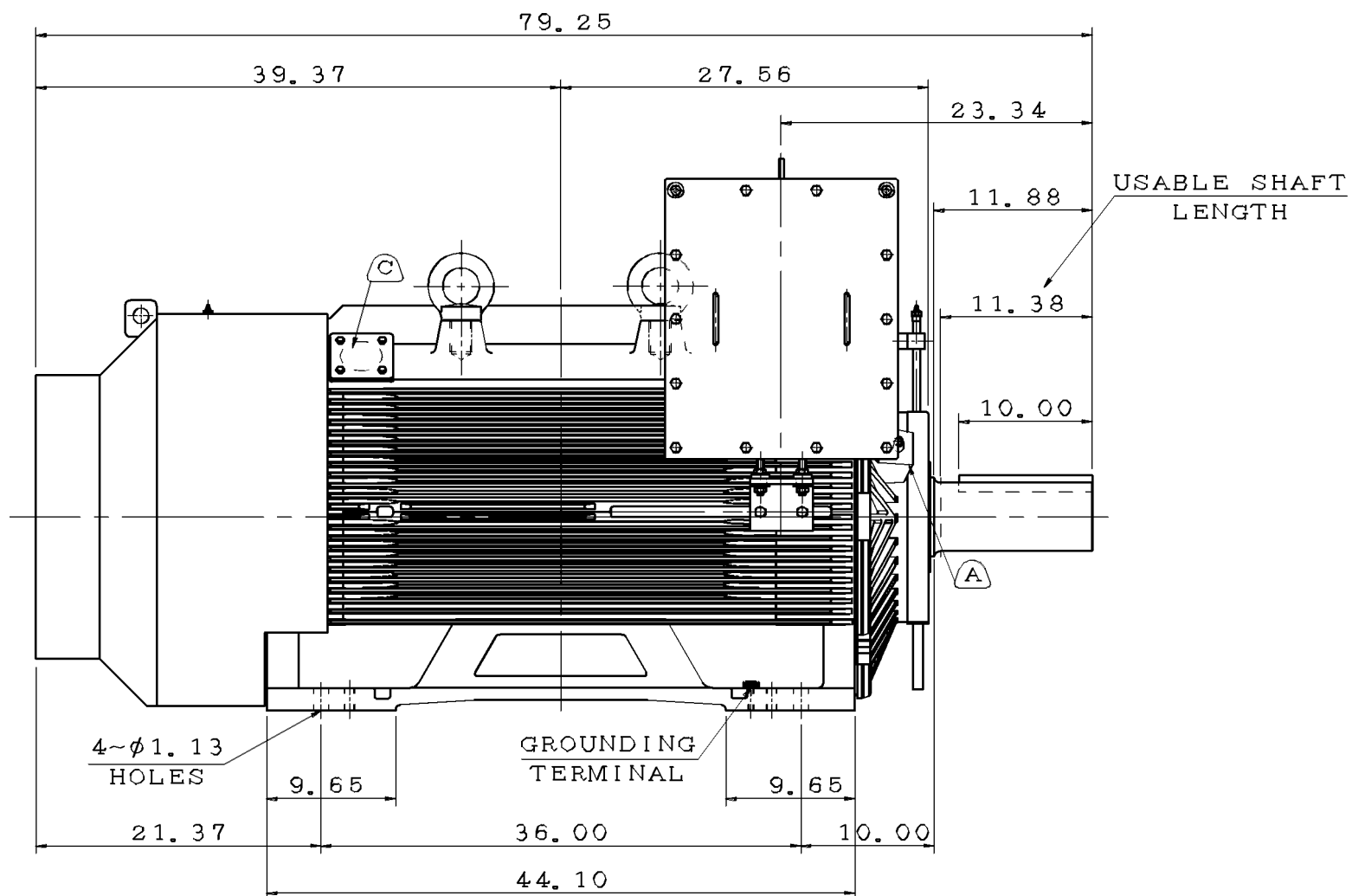
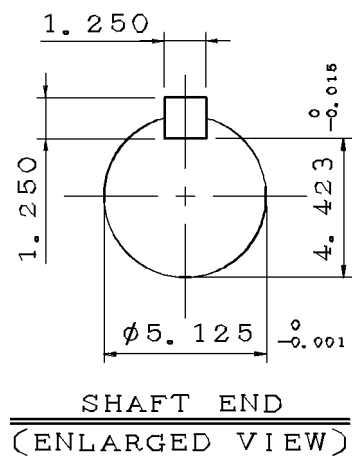
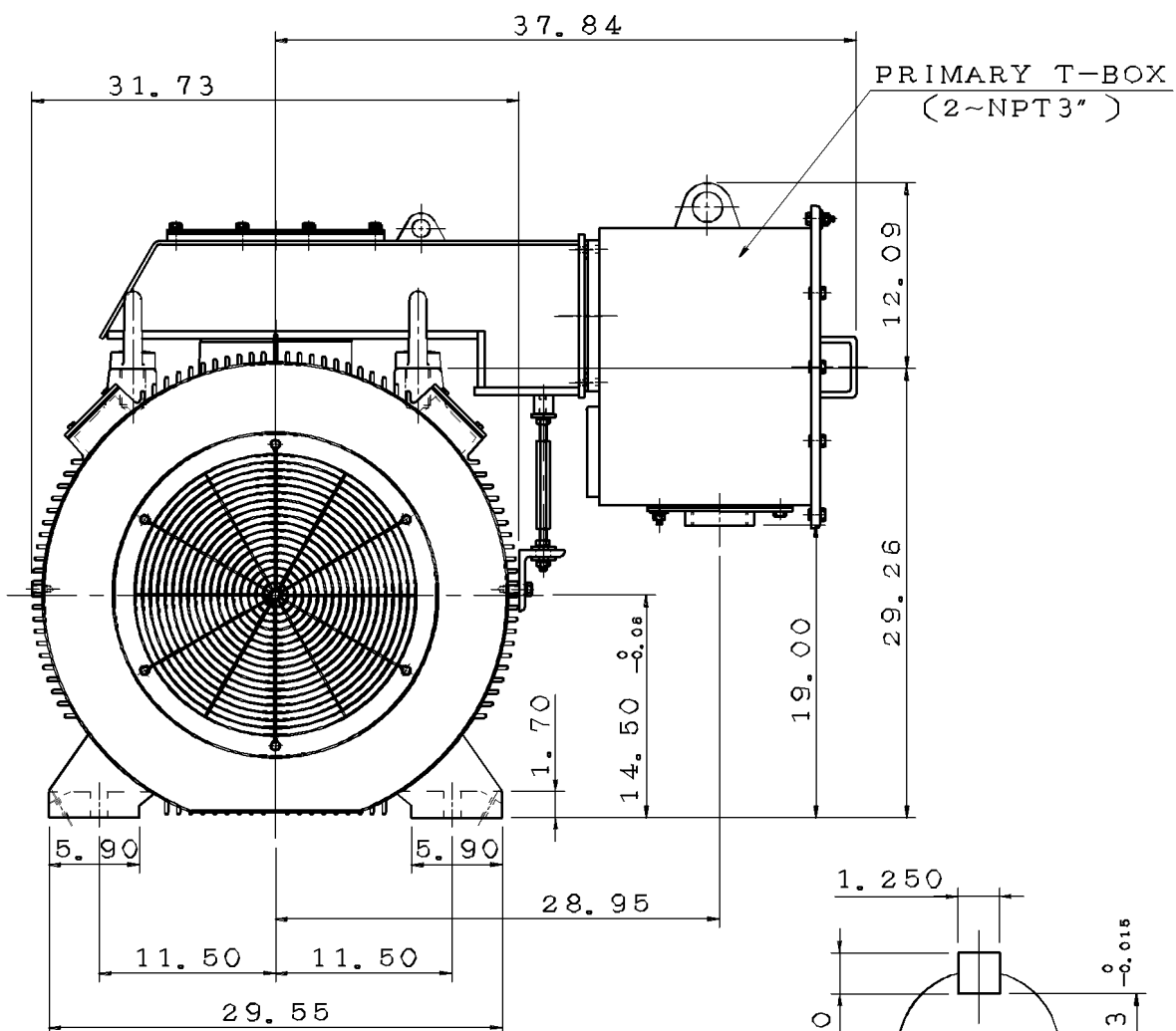

NOTE:

1. DIMENSIONS IN inch
2. FRAME NO. 5810C
3. F CLASS INSULATION
4. FOR BELT DRIVE
5. ENCLOSURE: IP55
6. BEARING SIZE: DRIVE-END NU330C3
OPP. DRIVE-END 6322C3
7. MOTOR APPROX. WEIGHT: 7300 lb

(B) FOR BEARING RTD, END BRACKETS SHALL BE PRE-DRILLED AND PLUGGED.

(C) FOR AUXILIARY, FRAME SHALL BE PRE-DRILLED AND COVERD WITH STEEL PLATE.

DATE	OUTLINE DIMENSIONS	
	3-PHASE INDUCTION MOTOR	

DWN.	L. JHENG	APR. 22. 2019
CHKD.	H. WANG	APR. 23. 2019
APPD.	C. WANG	APR. 23. 2019

TECO Westinghouse

DWG NO. 5A040C230
REV:01