

TYPE	OUTPUT		POLE	TIME RATING	VOLTAGE V	Hz	SYN. SPEED R.P.M
	HP.	kW.					
AEHHSY	450	335.7	8	CONT.	460	60	900

TOTALLY ENCLOSED FAN-COOLED TYPE. SQUIRREL-CAGE ROTOR

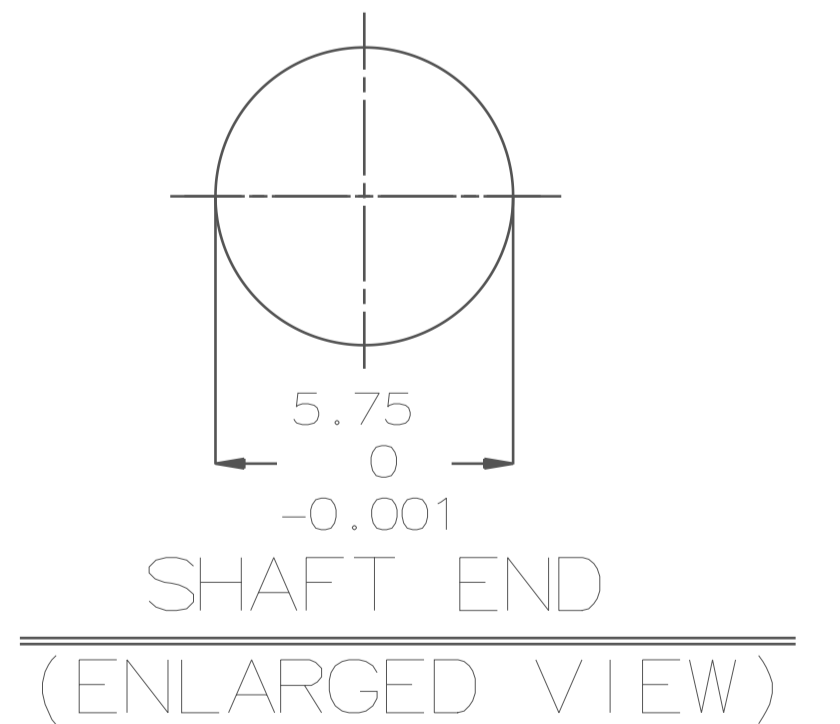
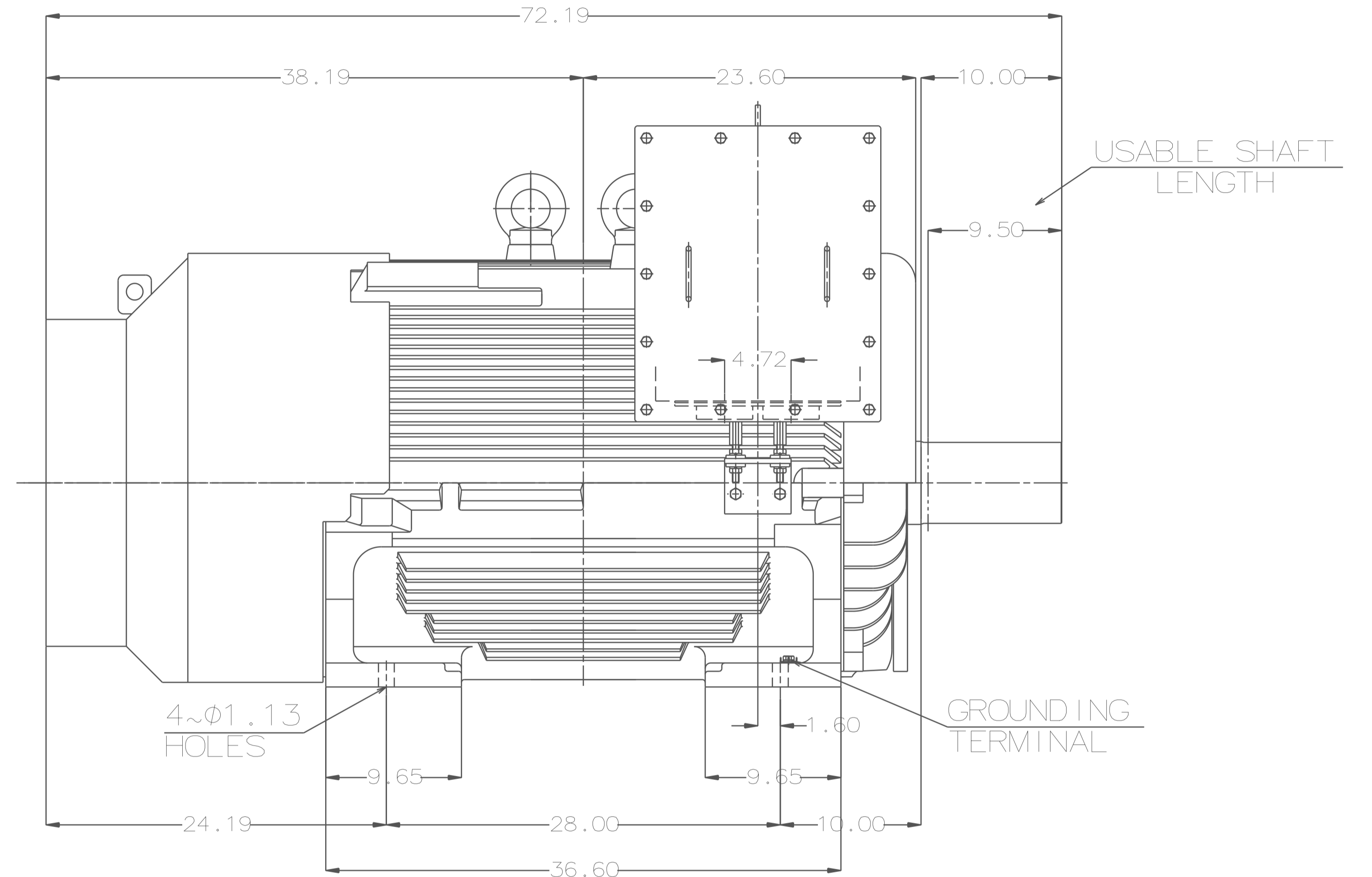
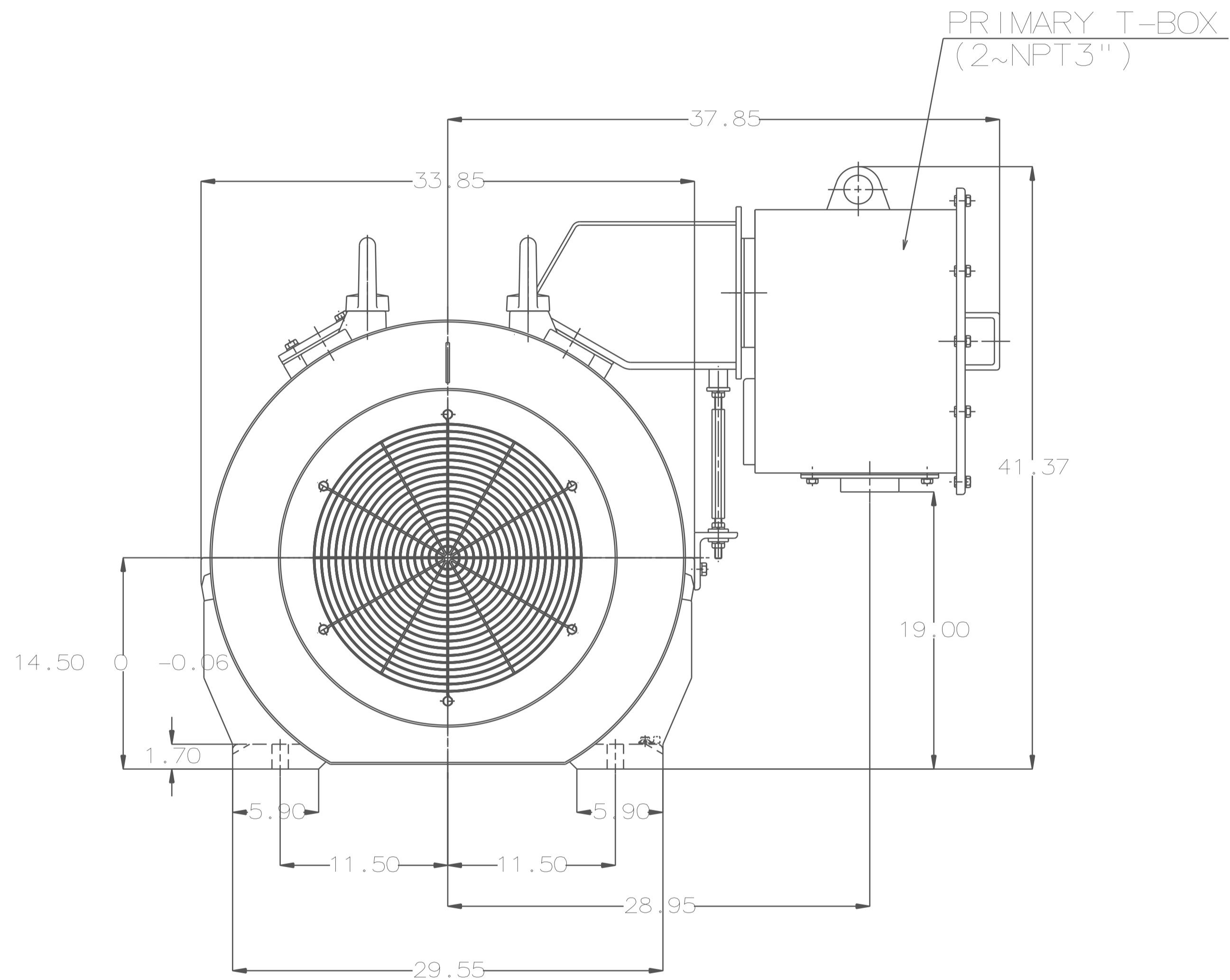

NOTE:

1. DIMENSIONS IN inch
2. FRAME NO. 5808UZ
3. F CLASS INSULATION, S.F.1.15
4. FOR DIRECT FLEXIBLE COUPLING
5. ENCLOSURE: IP55
6. BEARING SIZE: DRIVE-END 6330C3
OPP. DRIVE-END 6322C3
7. MOTOR APPROX. WEIGHT: 5450 LBS

DATE	12/7/15	OUTLINE DIMENSIONS
CATALOG #	EPY4508	

DWN.	J. CHANG	MAR. 05. 2015
CHKD.	H. HUANG	MAR. 05. 2015
APPD.	C. L IU	MAR. 05. 2015

TECO Westinghouse

DWG NO. 4B040G896
REV: 00