

TYPE	OUTPUT		POLE	TIME RATING	VOLTAGE V	Hz	SYN. SPEED R. P. M
	HP.	kW.					
AEHE-SY	600	447.6	4	CONT.	460	60	1800

TOTALLY ENCLOSED FAN-COOLED TYPE, SQUIRREL-CAGE ROTOR

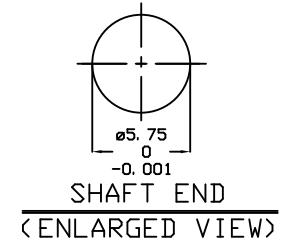
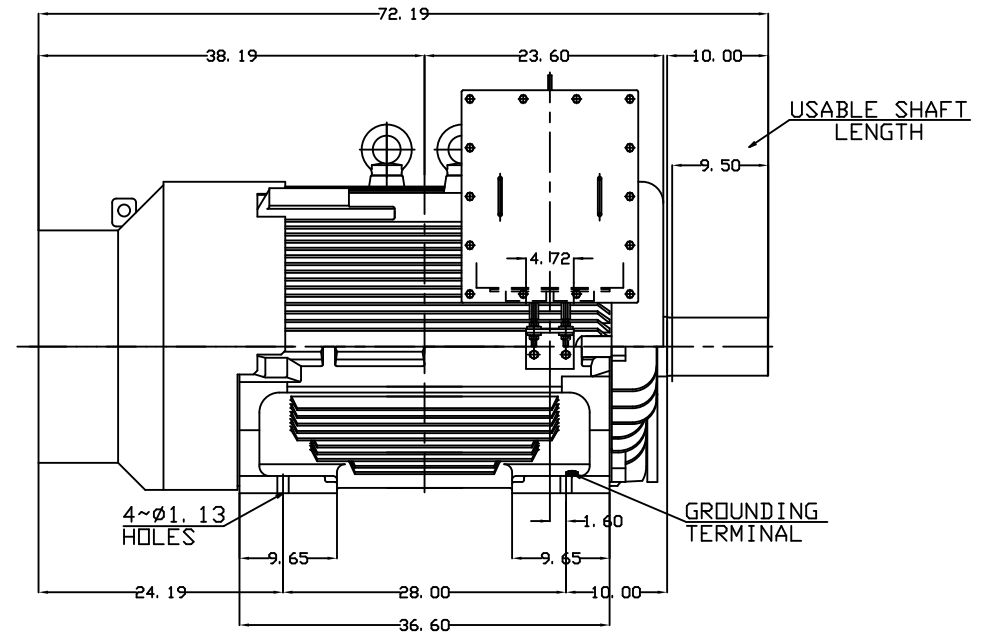
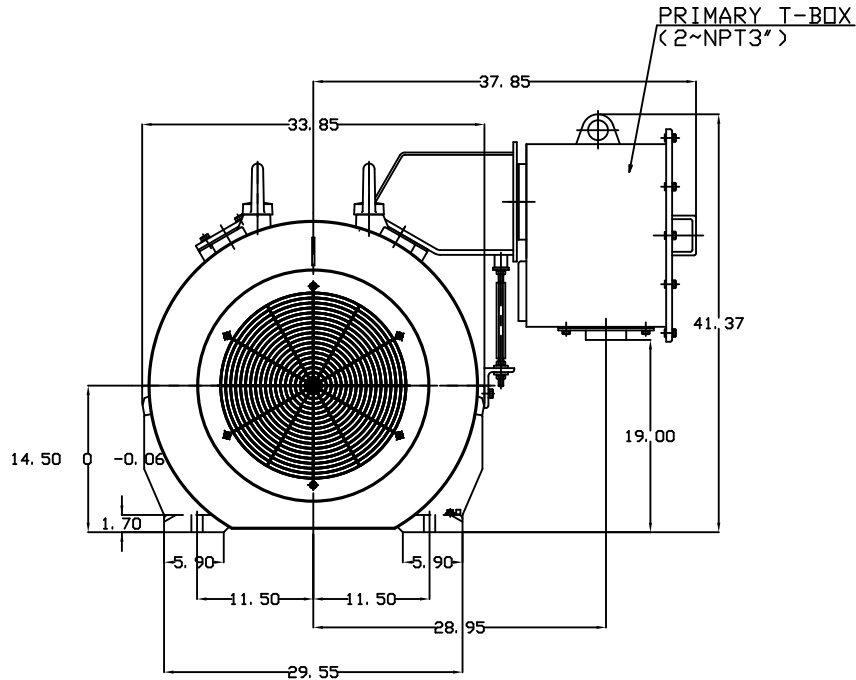

NOTE:

1. DIMENSIONS IN inch
2. FRAME NO. 5808UZ
3. F CLASS INSULATION, S. F. 1.15
4. FOR DIRECT FLEXIBLE COUPLING
5. ENCLOSURE: IP54
6. BEARING SIZE: DRIVE-END 6330C3
OPP. DRIVE-END 6322C3
7. MOTOR APPROX. WEIGHT: 5800 LBS

DATE	12/7/15	OUTLINE DIMENSIONS
CATALOG #	EY6004	3-PHASE INDUCTION MOTOR

DWN.	J. CHANG	MAR-05-2015
CHKD.	H. HUANG	MAR-05-2015
APPD.	C. LIU	MAR-05-2015

TECO Westinghouse

DWG NO. REV: 00
4B040G894