

TYPE	OUTPUT		POLE	TIME RATING	VOLTAGE	Hz	SYN SPEED R.P.M
	HP.	KW.					
AEH8B	500	373	6	CONT.	460	60	1200

TOTALLY ENCLOSED FAN-COOLED TYPE, SQUIRREL-CAGE ROTOR

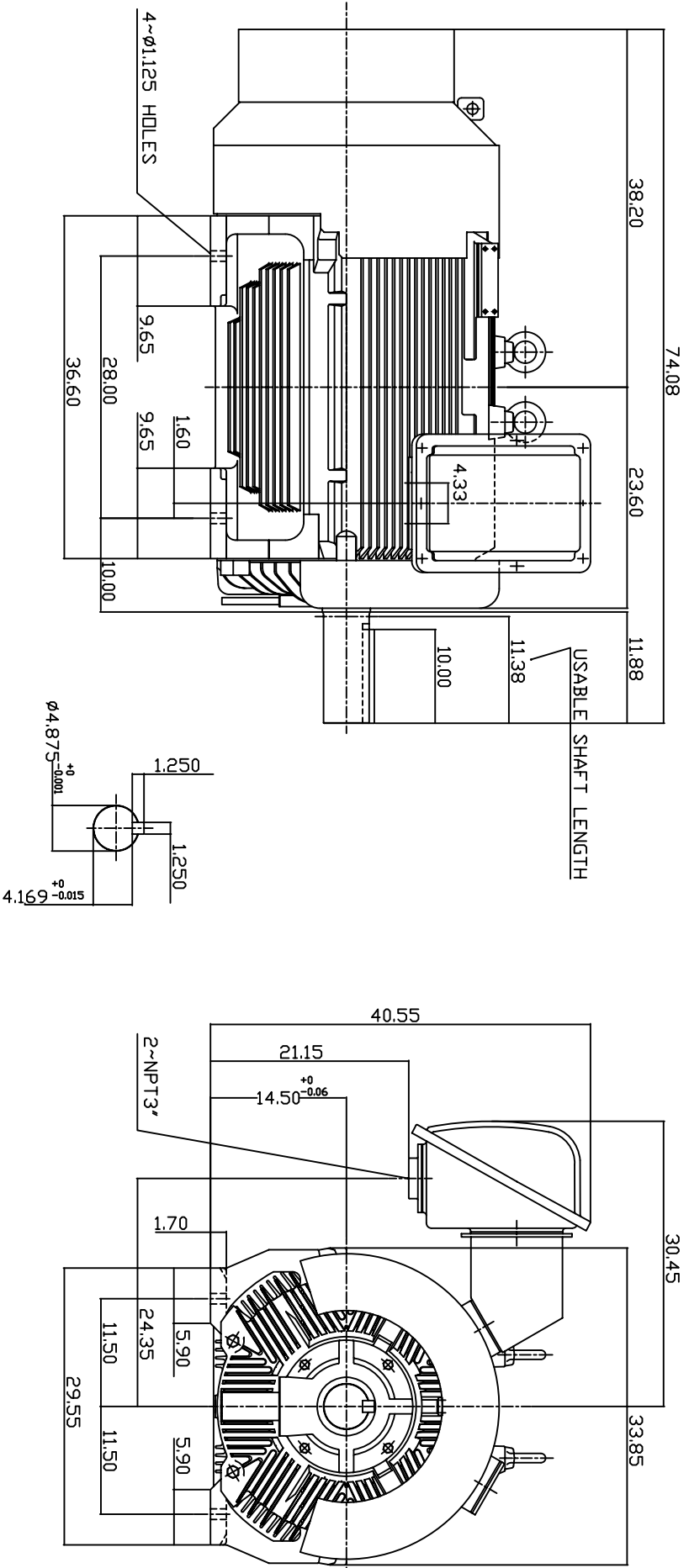

NOTE:

1. DIMENSIONS IN INCH.
2. FRAME NO. 5808B
3. F CLASS INSULATION, S.F.115
4. FDR BELT DRIVE
5. BEARING SIZE: DRIVE END: NU326
NON-DRIVE END: 6322
6. MOTOR APPROX. WEIGHT: 5600 LBS
7. ENCLOSURE: IP55
8. IMPRO SEAL ON BOTH ENDS.
9. NON-SPARKING FAN.
10. NOISE BELOW 83 DBA AT 1 METER AT NO LOAD.
11. VIBRATION VERTICAL/HORIZONTAL BELOW 0.08 IN/SEC AXIAL BELOW 0.06 IN/SEC.

TW-66C

DWN.	W.LLIN	MAR-04-2003
CHKD.	W.LLIN	MAR-04-2003
APPD.	C.WANG	MAR-04-2003

DATE	DCT 22, 2007	OUTLINE DIMENSIONS
CATALOG NO.	HB5006R	3-PHASE INDUCTION MOTOR



DWG NO. 3A040T184-4
REV: 00