

TYPE	OUTPUT		POLE	TIME RATING	VOLTAGE V	Hz	SYN. SPEED R.P.M
	HP.	kW.					
AEHNNH	100	74.6	6	CONT	230/460	60	1200

TOTALLY ENCLOSED FAN-COOLED VERTICAL HOLLOW SHAFT TYPE, SQUIRREL CAGE ROTOR

- NOTE:
- DIMENSIONS IN INCH
 - FRAME NO.444TP
 - F CLASS INSULATION, S.F.: 1.15
 - FOR DIRECT COUPLING.
 - BEARING SIZE:
UPPER BEARING: 7324B (UNINSULATED)
LOWER BEARING: 6316C3 (UNINSULATED)
 - LUBRICATION:
UPPER BEARING USE OIL.
OIL VISCOSITY: ISO VG68 [300SSU AT 100°F]
OIL QUANTITY: 2.6 GAL.
LOWER BEARING USE GREASE.(MOBIL POLYREX EM)
ROTATION: COUNTER-CLOCKWISE [VIEW FROM TOP].
 - WITH NON-REVERSE RATCHET MECHANISM.
 - WITH GIB KEY:0.375X0.375X2.874,1PCS
 - APPROXIMATE WEIGHT: 1950
 - REED FREQUENCY: 43 HZ
 - DOWNTHRUST: 10,100 LBS (L10-8800HRS)
 - SPACE HEATER RATED AT 120 VOLT, SINGLE PHASE, 109 WATTS, LEADS TERMINATE IN MAIN LEAD BOX.

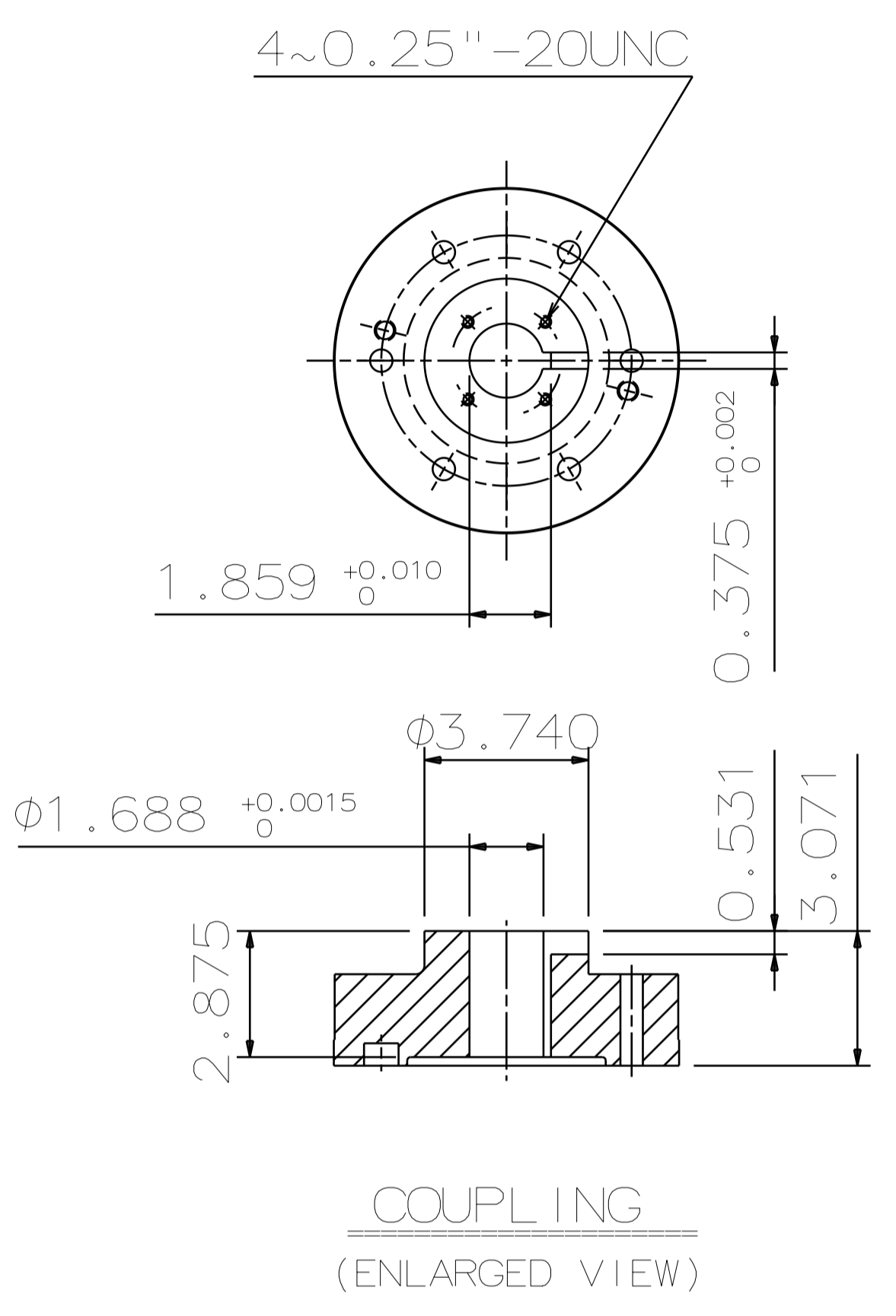

- A OIL FILLER [UPPER BEARING]
- B OIL GAUGE [UPPER BEARING]
- C OIL DRAIN [UPPER BEARING]
- D GREASE INLET [LOWER BEARING]
- E GREASE DISCHARGER [LOWER BEARING]
- F 2~M16 VERTICAL JACKING HOLES 180° APART IN MOTOR BASE.
- G M10 TAPPED HOLE IN MOTOR BASE WITH GROUNDING TERMINAL [R38-10] & BOLT LOCATED AS SHOWN.

DATE	DEC 08 2016	OUTLINE DIMENSIONS	
	VHTP1006	3-PHASE INDUCTION MOTOR	
DWN.	C.FU	APR.28.2015	DWG NO. REV:00
CHKD.	R.LEE	APR.28.2015	4B040L241
APPD.	C.LIU	APR.28.2015	

