

6

5

4

3

2

1

TYPE	OUTPUT		POLE	TIME RATING	VOLTAGE V	Hz	SYN. SPEED R.P.M
	HP.	kW.					
AEEHNH	300	223.7	6	CONT	460	60	1200

TOTALLY ENCLOSED FAN-COOLED VERTICAL HOLLOW SHAFT TYPE, SQUIRREL CAGE ROTOR

NOTE:

1. DIMENSIONS IN INCH
2. FRAME NO.5009
3. F CLASS INSULATION, S.F.: 1.15
4. FOR DIRECT COUPLING.
5. BEARING SIZE:
UPPER BEARING: 7328B [INSULATED]
LOWER BEARING: 6220C3 [UNINSULATED]
6. UPPER BEARING IS INSULATED. ANY METAL CONNECTIONS TO IT MUST BE INSULATED.
7. LUBRICATION:
UPPER BEARING USE OIL.
OIL VISCOSITY: ISO VG68 [300SSU AT 100 °F]
OIL QUANTITY: 1.8 GAL.
LOWER BEARING USE GREASE. [MOBIL POLYREX EM]
8. ROTATION: COUNTER-CLOCKWISE [VIEW FROM TOP].
9. WITH NON-REVERSE RATCHET MECHANISM.
10. WITH GIB KEY:0.500X0.500X3.07,1PCS
11. APPROXIMATE WEIGHT: 4600
12. REED FREQUENCY: 32 HZ
13. DOWNTHRUST: 12,400 LBS (L10-8800HRS)
14. SPACE HEATER RATED AT 120 VOLT, SINGLE PHASE, 218 WATTS, LEADS TERMINATE IN MAIN LEAD BOX.

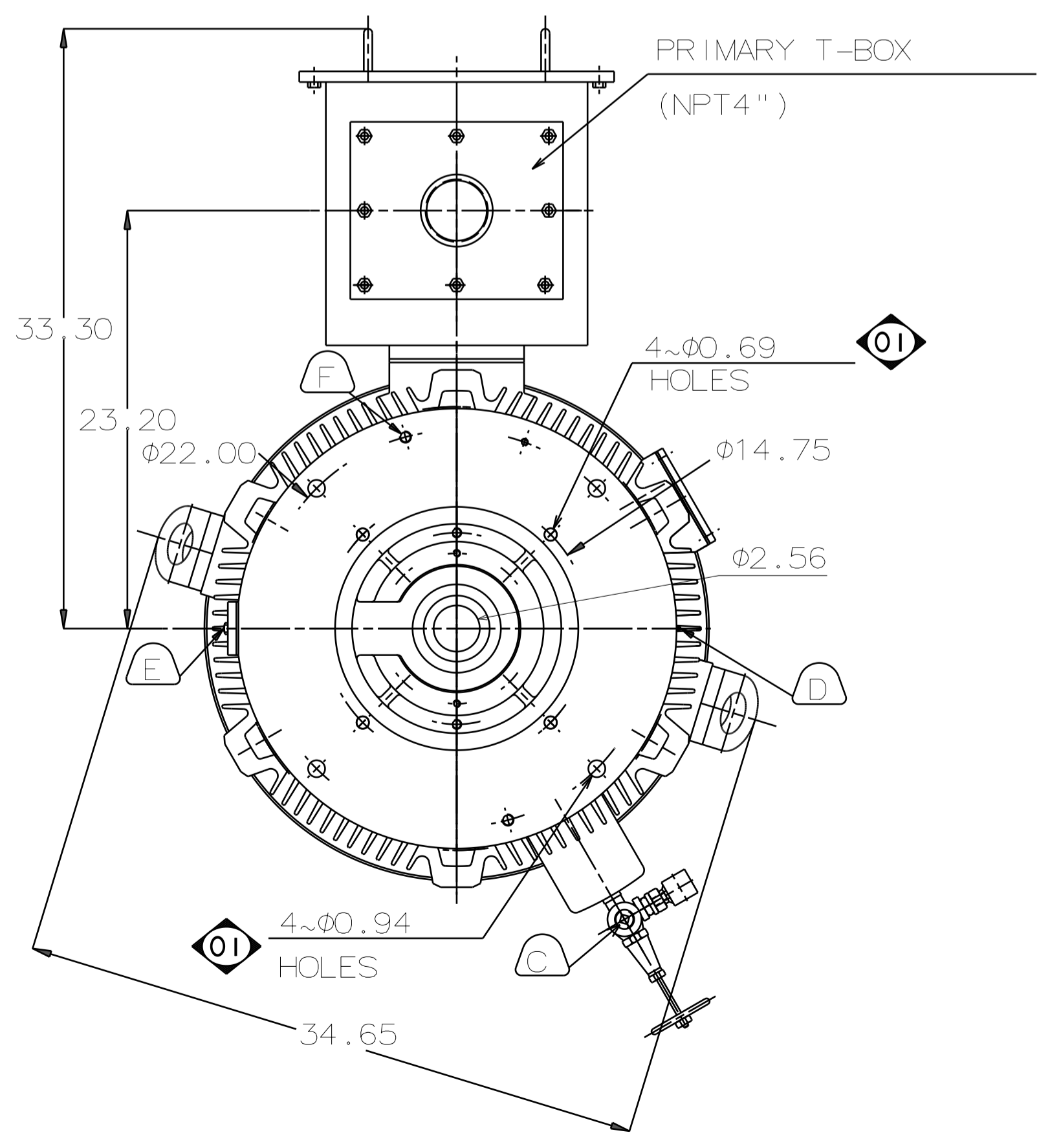
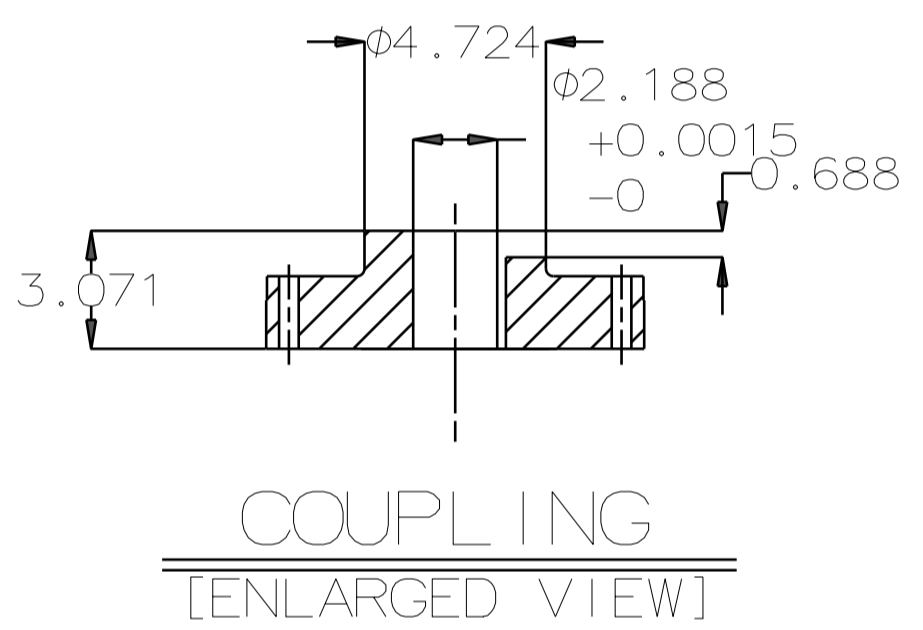
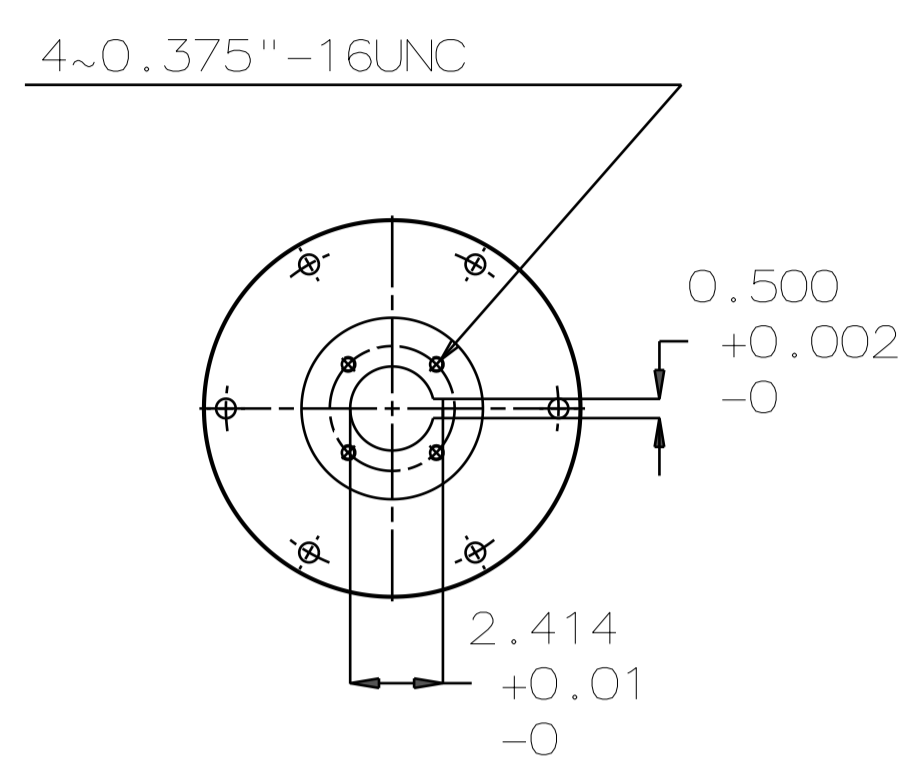
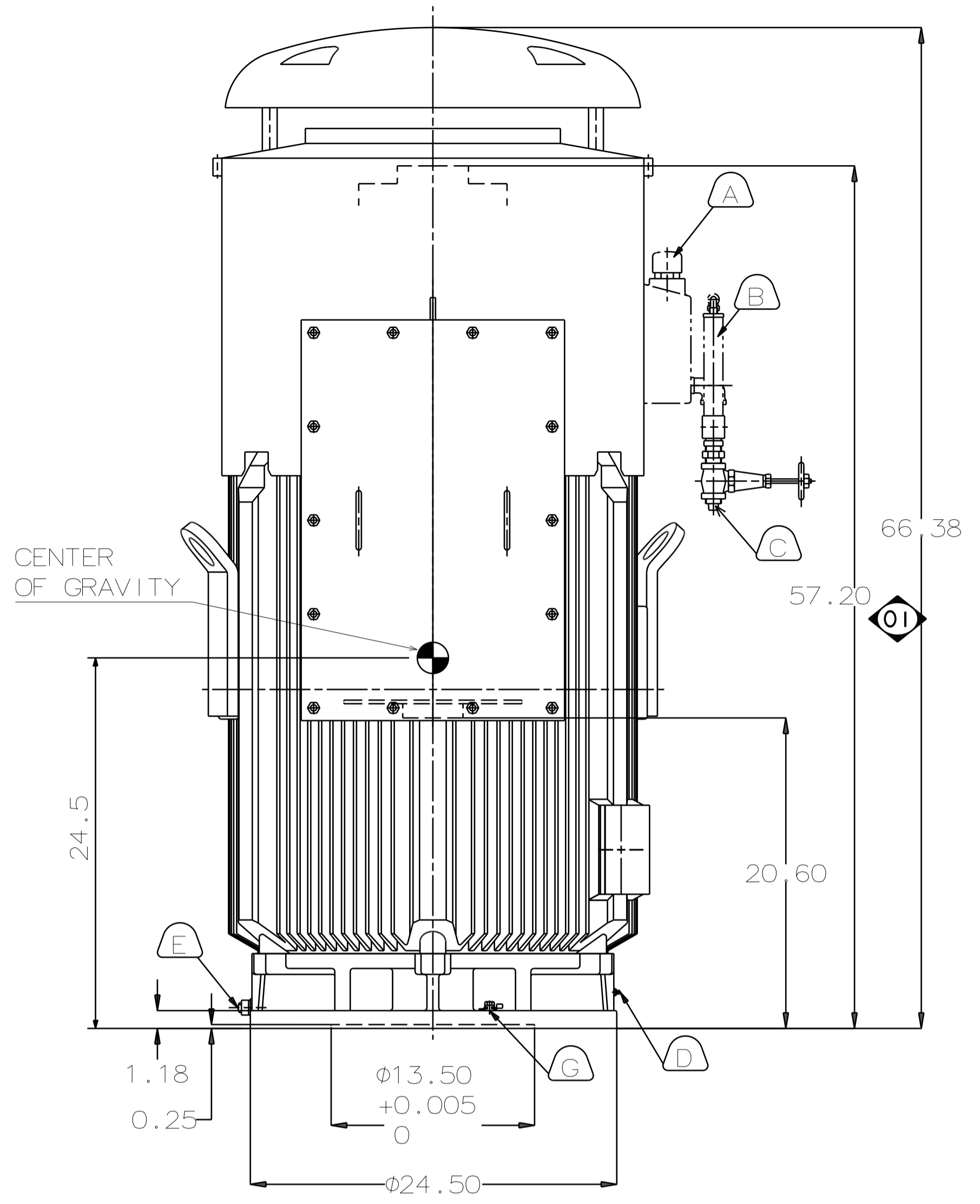

- (A) OIL FILLER [UPPER BEARING]
- (B) OIL GAUGE [UPPER BEARING]
- (C) OIL DRAIN [UPPER BEARING]
- (D) GREASE INLET [LOWER BEARING]
- (E) GREASE DISCHARGER [LOWER BEARING]
- (F) 2~M16 VERTICAL JACKING HOLES, 180°APART IN MOTOR BASE.
- (G) M10 TAPPED HOLE IN MOTOR BASE WITH GROUNDING TERMINAL [R38-10] & BOLT LOCATED AS SHOWN.

DATE	DEC 08 2016	OUTLINE DIMENSIONS	
	VHTP3006	3-PHASE INDUCTION MOTOR	
DWN.	C.FU	APR.17.2015	DWG NO. REV:01 4B040L120
CHKD.	R.LEE	APR.17.2015	
APPD.	C.LIU	APR.17.2015	
TECO Westinghouse			

6

5

4

3

2

1