

6

5

4

3

2

1

TYPE	OUTPUT		POLE	TIME RATING	VOLTAGE V	Hz	SYN. SPEED R.P.M
	HP.	kW.					
AMRKED	600	447.4	4	CONT	2300/4000	60	1800

ENCLOSED VENTILATED VERTICAL SOLID SHAFT TYPE, SQUIRREL CAGE ROTOR
NEMA WEATHER PROTECTED TYPE I

- NOTE:
1. DIMENSIONS IN INCH
 2. FRAME NO.5808
 3. F CLASS INSULATION, S.F. 1.15
 4. FOR DIRECT COUPLING
 5. BEARING SIZE:
UPPER BEARING: 29330+6028 (INSULATED)
LOWER BEARING: 6224C3 [UNINSULATED]
 6. UPPER BEARING IS INSULATED. ANY METAL CONNECTIONS TO IT MUST BE INSULATED.
 7. LUBRICATION:
UPPER BEARING USE OIL.
OIL VISCOSITY: ISO VG68 [300 SSU/100°F]
OIL QUANTITY: 2.9 GAL.
LOWER BEARING USE GREASE. [MOBIL POLYREX EM]
 8. ROTATION: COUNTER-CLOCKWISE [VIEW FROM TOP].
 9. WITH NON-REVERSE RATCHET MECHANISM.
 10. APPROXIMATE WEIGHT: 5370
 11. DOWNTHRUST: 30,600 LBS (L10-8800HRS)
 12. REED FREQUENCY: 35 HZ
 13. SPACE HEATER RATED AT 120 VOLT, SINGLE PHASE, 200 WATTS, LEADS TERMINATE IN MAIN LEAD BOX.

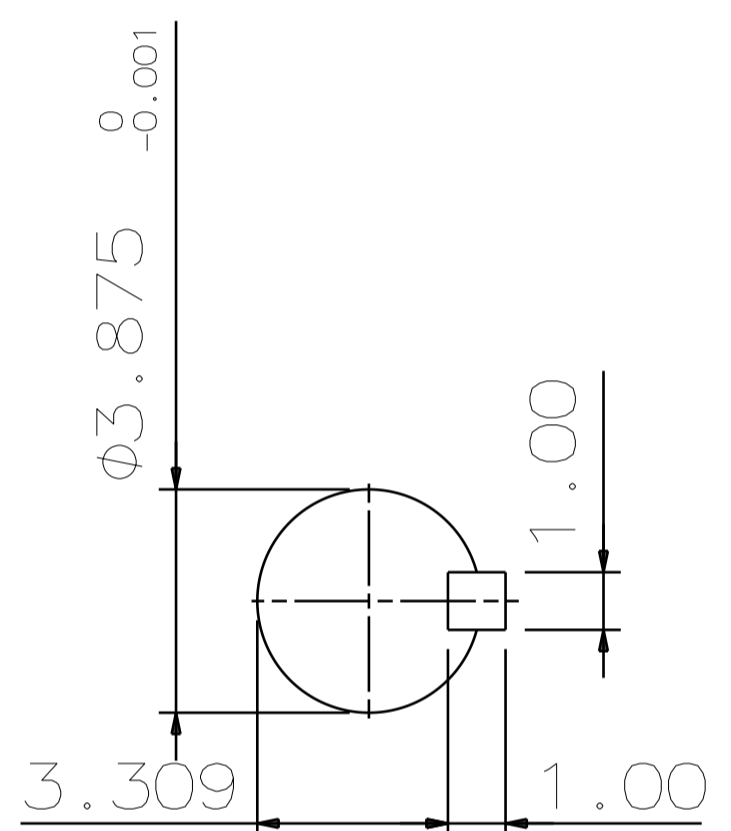
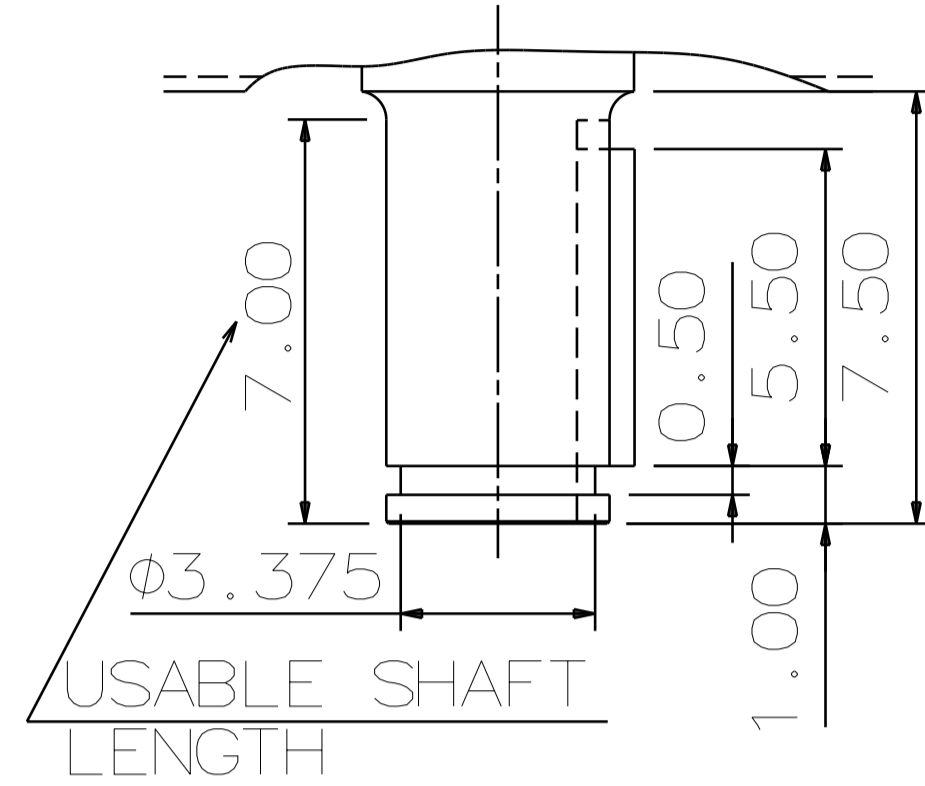
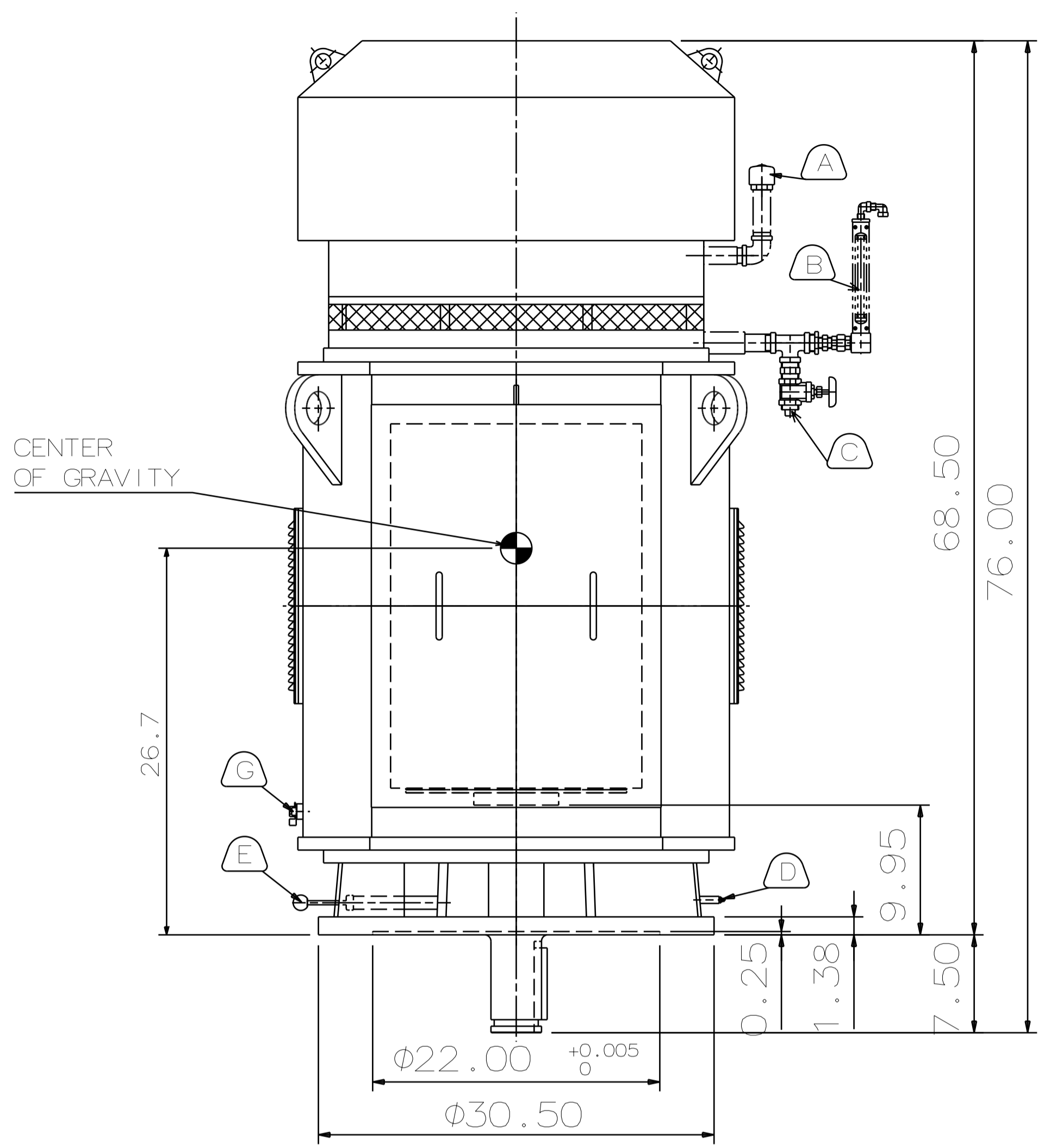

SHAFT END
(ENLARGED VIEW)

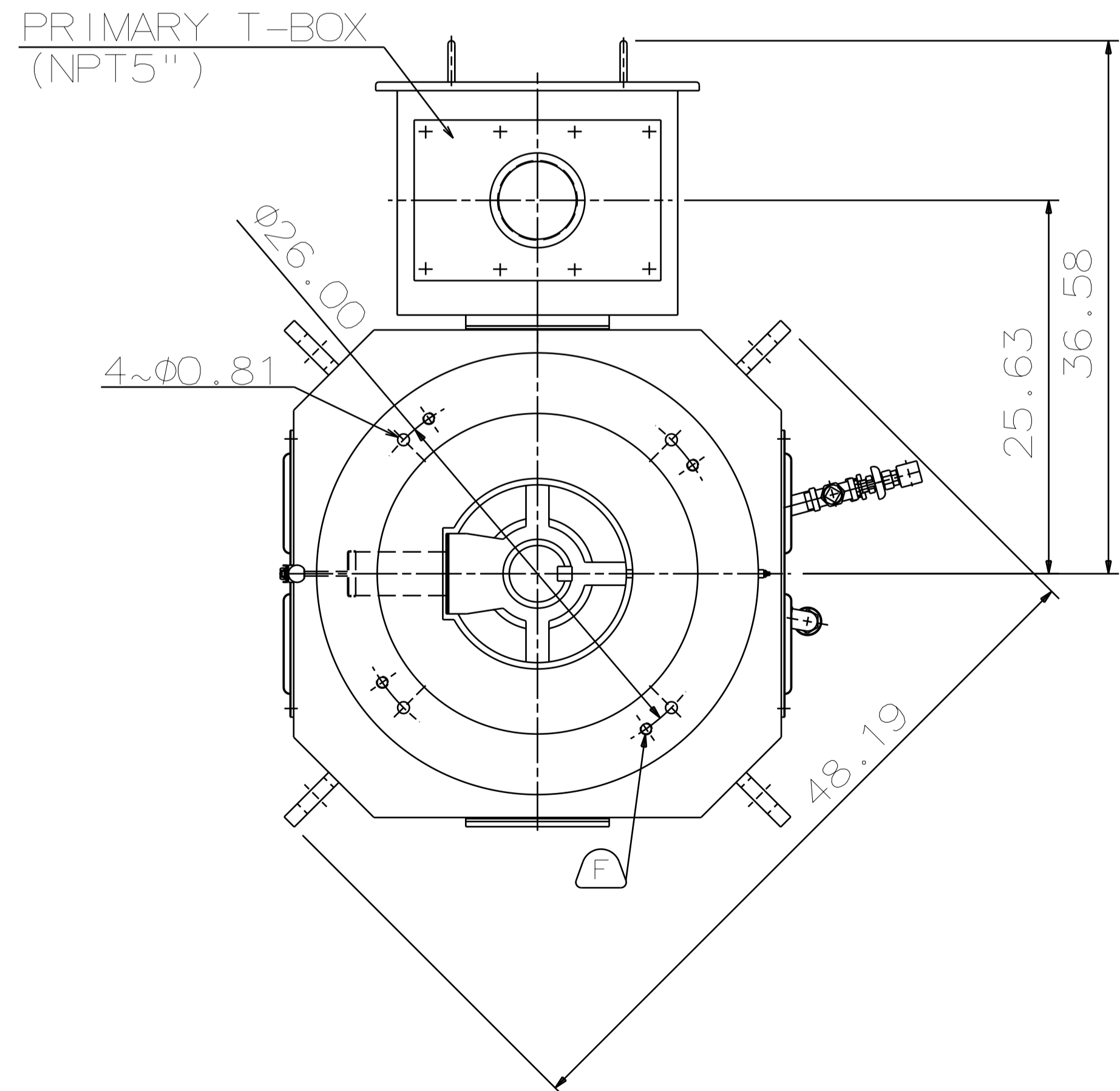

- (A) OIL FILLER [UPPER BEARING]
- (B) OIL GAUGE [UPPER BEARING]
- (C) OIL DRAIN [UPPER BEARING]
- (D) GREASE INLET [LOWER BEARING]
- (E) GREASE DISCHARGER [LOWER BEARING]
- (F) 4~M20 VERTICAL JACKING HOLES, 90°APART IN MOTOR BASE.
- (G) M10 TAPPED GROUNDING ON FRAME, WITH ONE GROUNDING STUDS & [R38-10] TERMINAL LOCATED AS SHOWN.

DATE DEC 08 2016	OUTLINE DIMENSIONS
VSKP6004	3-PHASE INDUCTION MOTOR

DWN.	Y. YANG	JUN.02.2015
CHKD.	R. LEE	JUN.02.2015
APPD.	C. LIU	JUN.02.2015

TECO Westinghouse	DWG NO.	REV:00
	4B040L495	

6

5

4

3

2

1