

DATE: NOV 27, 2019
 CATALOG NO.: DM1/54

OUTLINE DIMENSIONS
 PERMANENT MAGNET MOTOR

MOTOR TYPE: DVEM
 FRAME NO. 145T

Pole	HP	kW	Hz	VOLT	r/min(rpm)
6	1.5	1.12	90	460	1800

Ins	Rating	Dimension in	Approx Weight	Bearings
F	CONT.	inch	46 lbs	DE: 6205ZZ NDE: 6205ZZ

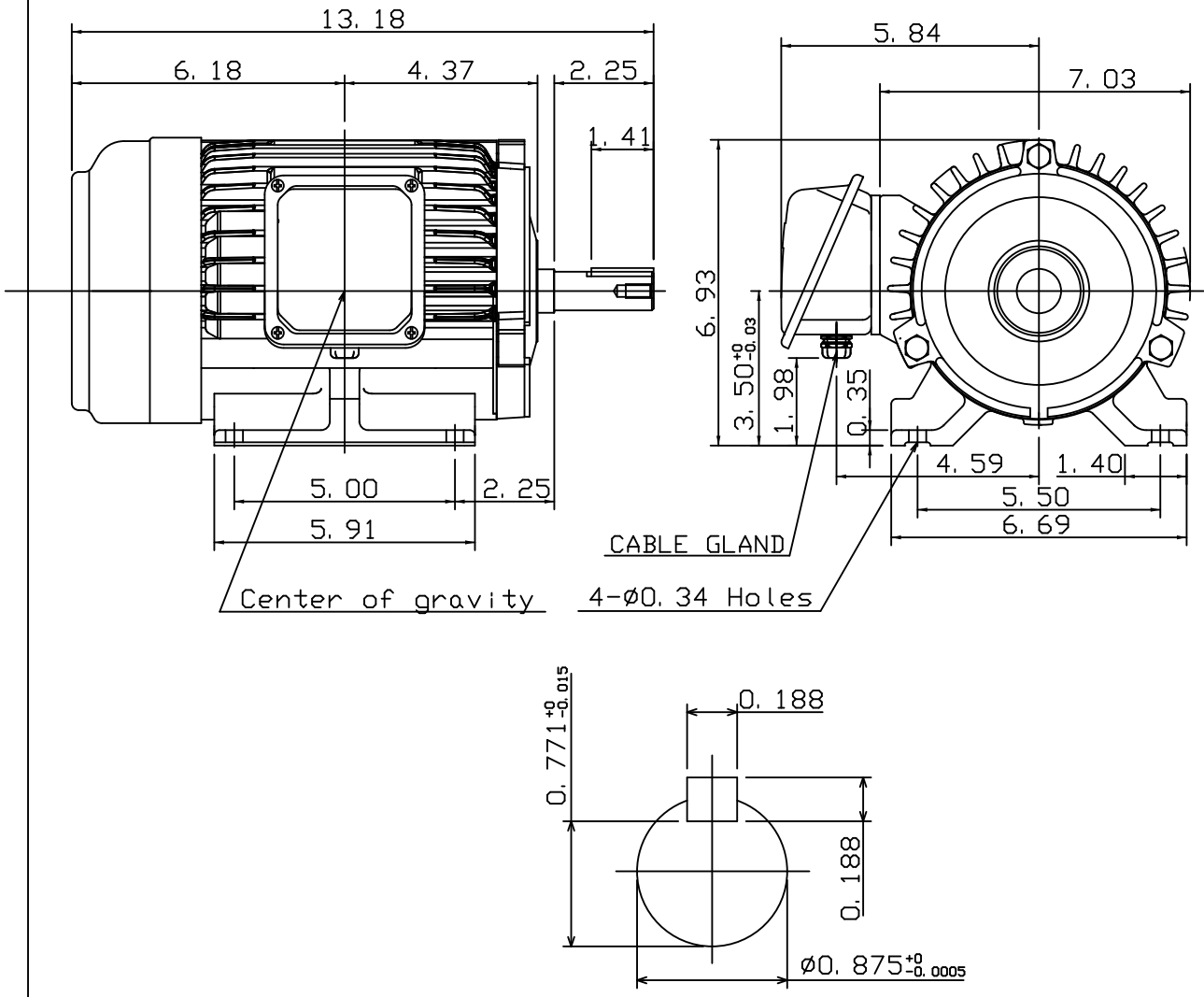

Note: 1. IP55 Protection
 2. CABLE GLAND(PF1/2")
 SUITABLE FOR RANGE
 ∅0.27~∅0.47

③ 06.20.19 邱柏人

DWG.	B. R. Chiu	08-07-18
CHKD.	P. Z. HSIEH	08-07-18
APPD.	L. S. Hung	08-07-18



DWG NO.
 31049R316033

TECO Westinghouse

ISSUED 12/2/2019	PERFORMANCE DATA 3-PHASE INDUCTION MOTOR	ENCLOSURE TEFC
TYPE DVEM		CATALOG# DM1/54

NAMEPLATE INFORMATION

OUTPUT		POLE	FRAME SIZE	VOLTAGE	HZ	RATED AMBIENT	INS. CLASS	TIME RATING	SERVICE FACTOR
HP	KW								
1.5	1.1	6	145T	460	90	40°C	F	CONT.	1.15

VARIABLE FREQUENCY DRIVE SERVICE

VARIABLE TORQUE				OHMS/PHASE EQUIVALENT WYE CIRCUIT (AT RATED OPERATING TEMPERATURE 25°C)			
HZ	HP	RPM	TORQUE (lb-ft)	RESIST.	Ld	Lq	BEMF
9~90	0.09~1.5	180~1800	2.58~4.30	7.738 Ω	24.01 mH	42.49	169 mV/rpm

CONSTANT TORQUE				CONSTANT HORSEPOWER			
HZ	HP	RPM	TORQUE (lb-ft)	HZ	HP	RPM	TORQUE (lb-ft)
60~90	0.98~1.5	1200~1800	4.3	90~135	1.5	1800~2700	4.30~2.87

TYPICAL PERFORMANCE

FULL LOAD RPM	EFFICIENCY			POWER FACTOR			SOUND PRESSURE LEVEL @ 3 FT Db(A)
	FULL LOAD %	3/4 LOAD %	1/2 LOAD %	FULL LOAD %	3/4 LOAD %	1/2 LOAD %	
1800	87.2	87.2	87	99.3	99.5	99.6	55.9

CURRENTS		TORQUE	INERTIA
NO LOAD (A)	FULL LOAD (A)	FULL LOAD (lb-ft)	ROTOR WR2 (lb-ft ²)
0.50	2.30	4.30	0.048

APPROVED:	M. PRATER	DRAWING NO.	31057DM1/54	REVISION:	0
-----------	------------------	-------------	--------------------	-----------	----------

TECO ® Westinghouse	OUTLINE DIMENSIONS	MOTOR TYPE: DVEM
	DATE	NAME PLATE

 <small>US 171882</small>	MAX-PM TM PERMANENT MAGNET SYNCHRONOUS MOTOR			
	TYPE	DVEM—NFO1K1EA010		
	HP/kW	1.5HP/1.1kW	TORQUE	4.3 lb-ft
	VOLTS	460 V	PH/INS	3/F
	AMPS	2.3 A	AMB/SF	-20~40°C/1.0
	BEMF	169 mV/rpm	RATING	CONT.
	Lq	30.35 mH	IP	55
	Ld	17.15 mH	POLE	6
	RESIST.	4.314 Ω(L-L)	WEIGHT	42.0 lb
	RATING	1800 rpm	MAX	2700 rpm
		90 Hz		135 Hz
	FRAME	145T	DATE	2019
	SER. NO.	E819B501001	EFF.	87.2 %
	CAT. NO.	DM1/54	PO NO.	STKS0001K
	DE BRG	6205ZZ	NDE BRG	6205ZZ
TECO ® Westinghouse		MOTOR COMPANY ROUND ROCK, TEXAS		

MADE IN TAIWAN 31045H344X808

NOTES :

1. DIMENSIONS: 3.15" L x 2.20" H (80mm x 56mm)
2. THICKNESS IS 0.02" (0.5mm)
3. MATERIAL: STAINLESS STEEL (SUS430CS)
4. PART NUMBER: 31045H344X808
5. FOR USE ON TYPE: DVEM (F#143T~286T; 6P)
6. CERTIFICATIONS:



CSA APPROVED.

◇		
---	--	--

DWG.	邱柏人	11.11.19	TECO ® Westinghouse	DWG NO.	31057M118090
CHKD.	謝弼任	11.12.19			
APPD.	王祈欣	11.12.19			



CONNECTION DIAGRAM

MODEL

DATE :
June.24.2019

For Y Connection

DAC-1548-4

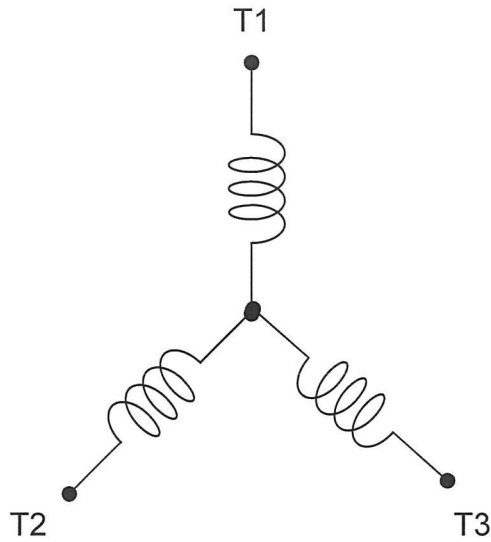

SCHEMATIC – Y CONNECTION

ROTATION

(VIEWED FROM DRIVE END)

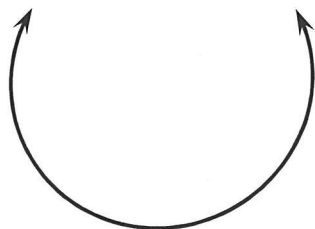

CONNECTION

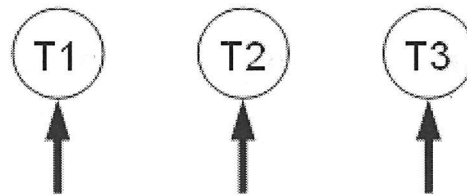

ACROSS-THE-LINE

APPD.	Wanghy	06,24,'19
CHKD.	Mingte	06,24,'19
DWN.	P.J.Huang	06,24,'19



DWG NO :
DAC-1548-4

T-N CURVE

NO.: TDTPM19702021

TYPE: DVEM

POLE: 6

HP : 1.5

VOLT.: 460

Tmin. : 3.5 Lb-ft

Tmax. : 8.9 Lb-ft

Tf : 5.9 Lb-ft

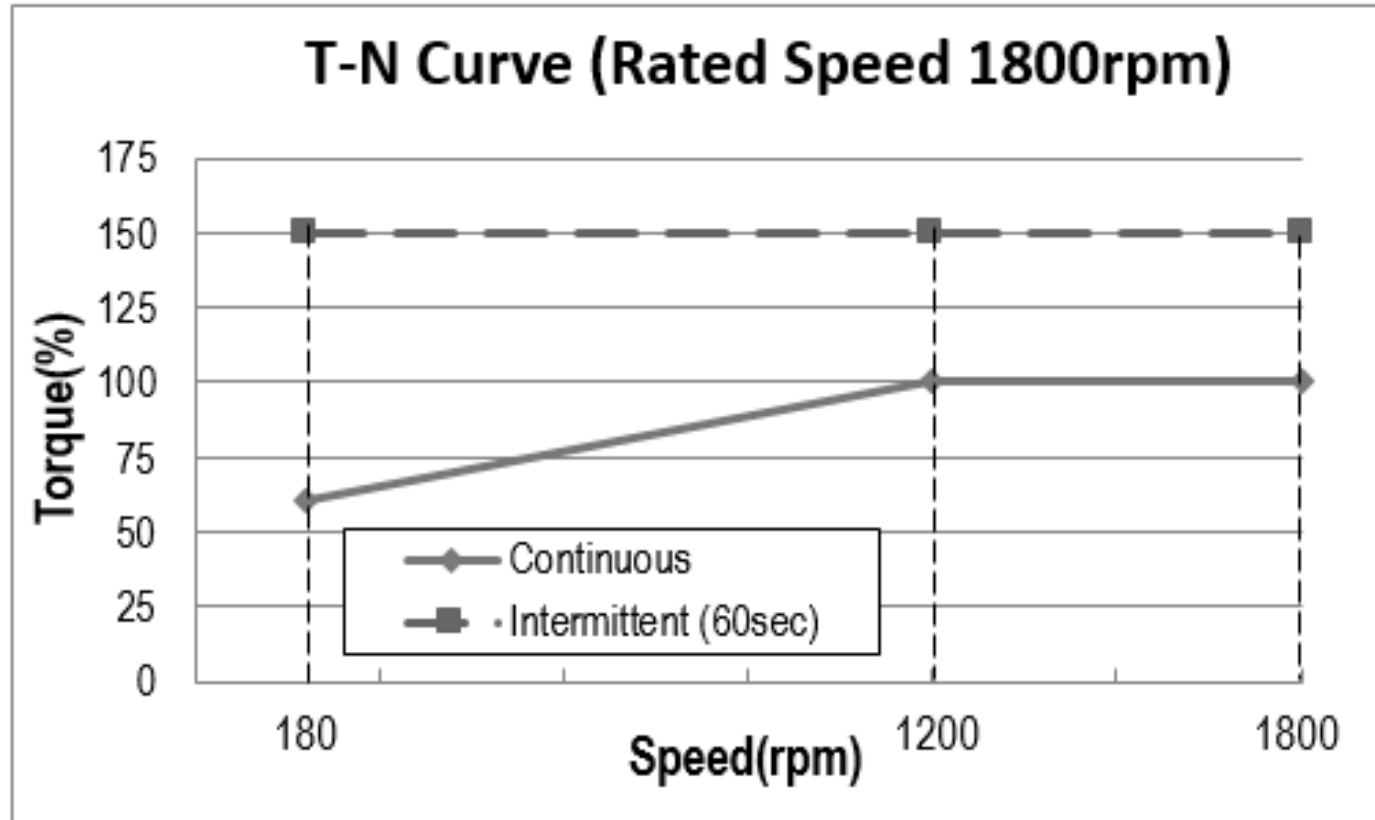

APPD.	Mingte	20191114
CHKD.	Mingte	20191114
DWN.	P.J. Huang	20191114

TECO   **Westinghouse**

DWG NO. Rev.00
TDTPM19702021
T-N

Efficiency & Power Factor CURVE

NO.: TDTPM19702021

TYPE: DVEM

POLE: 6

HP : 1.5

VOLT.: 460

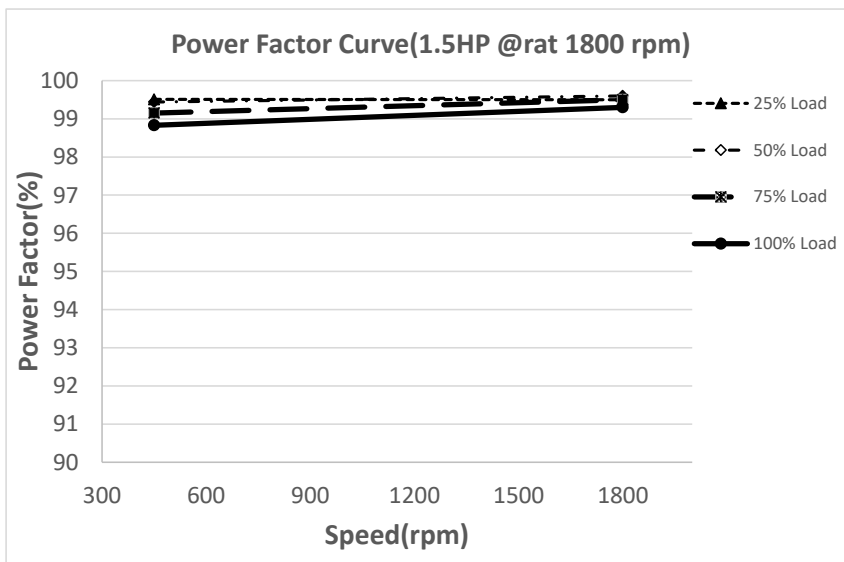
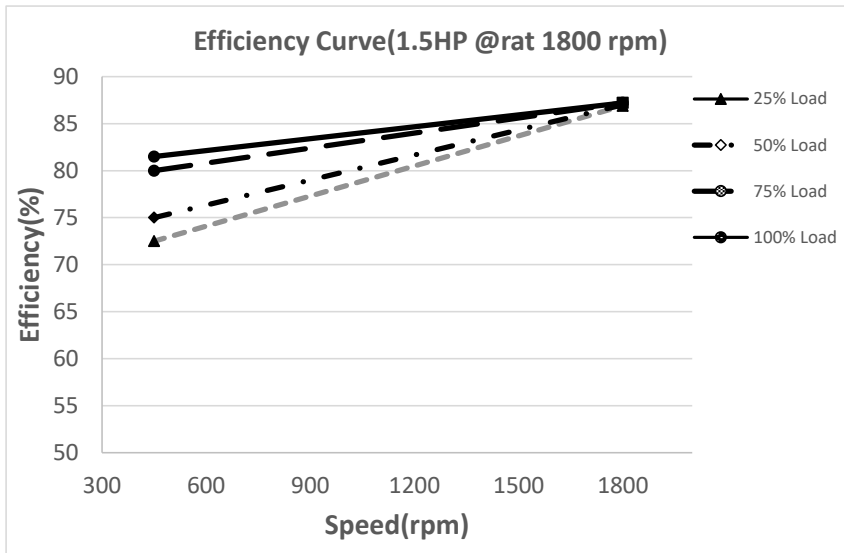

APPD.	Wanghy	20191129
CHKD.	Mingte	20191129
DWN.	P.J. Huang	20191129



DWG NO.	Rev.00
TDTPM19702021	
Efficiency&Power Factor	



High-Efficiency Permanent-Magnet Synchronous Motor

Instruction Manual

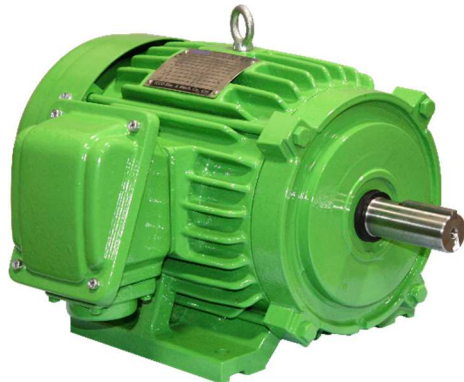

1BW0-A1-C-LD-426

Contents

1. Introduction3
2. Preparation	
2.1 Receiving inspection7
2.2 Installation7
2.3 Wiring8
3. Commissioning and operation	
3.1 Before operation8
3.2 Operation9
4. Maintenance and checks	
4.1 Routine checks9
4.2 Periodic checks10
4.3 Fitting checks10
5. Storage 11
6. Disassembly and assembly 11
7. Troubleshooting 12
8. Maintenance service 14

1. Introduction

Please peruse the Instructions before use

Introduction

Thank you for choosing TECO High-Efficiency Permanent Magnet Synchronous Motor (PMSM) products. This instruction manual is applicable to PMSM customers. It addresses precautions for motor operation. Please peruse it before using the motor.

Please place this instruction manual near the motor products. If you are to lend or transfer this product, please attach this instruction manual to the product. When installing the product on machines or equipment to be coupled for use, please make sure that the installation methods have been referred to this instruction manual.

In addition, due to other safety considerations, the motor installation and configuration may not match the contents of this document. If you have any query, please consult our company or distributor.

Safety precautions

Before using the product (installation, operation, maintenance, and check, etc.), please confirm the consistency of this instruction manual with the product, and read all the documents come with the product carefully. Please be familiar with the equipment, safety information and precautions mentioned in this instruction manual.

After thoroughly reading this instruction manual, please place it nearby the product.

In this manual, safety precautions are divided into "DANGER" and "CAUTION".



: Deaths or severe injuries may occur in case of incorrect handling.



: Minor or moderate personal injury may occur in case of incorrect handling.



DANGERS

(General)

- The works to check transportation, installation, piping, wiring, operation, running and maintenance shall be handled by qualified professionals to avoid electric shock, personal injury and fire.
- Do not perform the checks under powered state; turn off the power supply prior to work is a must to avoid electric shock.
- During operation, even if the power supply is turned off, the motor terminal may still generate voltage. Therefore, do not touch it to avoid the possible electric shock or injury. Please wait until the motor comes to complete stop before performing the works.
- To start motor at its off status, and under the condition of constant power, the load curve at a rpm above the rated rpm of motor is lower than the curve at rated torque, so the applicability of specifications should be considered to avoid motor burnout.
- Please install appropriate guard barrier and protective covers at the shaft extension end or at the position of other rotating parts of the motor to prevent personal injury by drawing.
- Please truly install the protective and insulating isolation devices for power cables to avoid the hazard of electric shock.
- Do not use the product in flammable environment.

(Installation and adjustment)

- Please confirm that the grounding wire of motor has been installed properly to avoid hazard of electric shock.
- To install product on ceiling or wall, please follow the product catalogue and relevant statutory & regulatory requirements for operation to avoid dangerous conditions of falling.
- Please make sure that the protective device has been connected to function normally to avoid fire hazard.
- Please do not perform operation without installing the top cover of T-box to avoid the hazard of electric shock.

(Wiring and routing)

- To configure the wiring connection for power cable shall follow the wiring diagrams and instruction manual for connection; and an incorrect wiring connection may lead to electric shock or fire hazard.
- Please do not over bend, pull and squeeze the power cable or motor lead to avoid electric shock or fire hazard.

(Operation)

- Please do not approach or touch the rotating body during operation to avoid danger.
- Be sure to turn off the power supply at power failure to avoid the danger resulted from power restoration.

(Maintenance and checks)

- To wire the power supply cable for connection shall follow the wiring diagrams and instruction manual for connection to avoid electric shock or fire hazard.

CAUTIONS

(General)

- Please ensure that a suitable space for maintenance and check is reserved around the installation position of motor in order to avoid the hazard of electric shock or personal injury.
- Please do not use the fittings other than the motor-specified fittings to avoid hazard of electric shock and personal injury.
- Please do not put your hands or place articles at the opening of motor to avoid electric shock, personal injury or fire.
- Please do not use damaged motor to avoid personal injury or fire.
- To work at high place shall be protected by relevant safeguard measures to avoid falling hazard.
- Any modification made to motor for use by customer, which is out of the scope of product warranty, will void warranty for subsequent liability of compensation.
- Nameplate and specifications plate shall be placed at an easily identifiable place without being covered by other articles.
- Please do not remove the nameplate and specifications plate.

(Transportation)

- Please pay attention to the hazards of dropping and tilting & falling, etc. during the transportation process.
- Please hoist the motor at the lifting-designated positions. After assembling the machine load in position at customer side, do not use the lifting positions of motor to hoist the entire machinery equipment.
- Please be sure to verify that the hoisting equipment is able to bear the load against the weight of packed motor to avoid hazards of dropping, tilting & falling and damage, etc.

(Unpacking)

- Before unpacking, please make sure that the motor is placed at a stable platform to avoid hazard of injury.
- After unpacking, please confirm that the product specifications and model number to avoid personnel injury and product damage caused by installation errors.

(Installation and adjustment)

- Do not place inflammable materials around the motor to avoid fire hazard.
- Do not pile up obstacles around the motor to avoid abnormal ventilation, which will reduce cooling efficiency and overheat the ambient temperature to cause fire hazard.
- If motor is to be connected to a pulley equipment, please:
be cautious to the tension device and pulley, etc.;
properly adjust the belt tension, pulley and bolts;
make sure that they are firmly locked to avoid injury from flying-off part and risk of equipment damage; and pay attention to the accuracy of installation for a direct-coupling motor, such as the concentricity and parallelism, etc.
- Please do not touch the rotating part, and please install protective cover, etc. means on the exterior of rotating part to avoid the hazard of injury.
- Please check the rotating direction prior to coupling the machine.

- Please do not walk or ride on motors to avoid hazard of injury.
- Please do not use hands to touch the keyway of motor shaft end to avoid hazard of injury.

(Wiring and routing)

- Please do not touch terminals when measuring the withstand voltage and insulation resistance so as to avoid hazard of electric shock.
- Please follow the technical regulations and electrical codes for electrical equipment to perform the wiring connection in order to avoid hazard of fire.

(Operation)

- A temperature rise will occur during the operation process, please do not use your hands or body to touch motor to avoid hazard of scald.
- If an error or abnormality occurs, please stop motor operation immediately to avoid the risk of electric shock, personal injury and fire.

(Maintenance and checks)

- When measuring the insulation resistance, please do not touch terminals to avoid hazard of electric shock.
- To charge or discharge the grease in or from the bearings, if needed, please do not touch the rotating body to avoid hazard of injury.
- A running motor will result in a temperature rise to its external frame bracket, please pay attention to it when performing maintenance and check to avoid hazard of scald.

(Repair and disassembly)

- Maintenance and disassembly of motors shall be carried out by qualified professionals to avoid electric shock, personal injury and fire risk.

2. Preparation

1. Receiving inspection

After receiving the motor, please pay attention to the following matters:

- (1) Please check the certificate of delivery and the certificate of product compliance.
- (2) Please check if the fittings are missing, damaged or rusted.
- (3) Manually rotate the shaft end to confirm for a smooth rotation. For a motor in large capacity, a heavier feeling will be sensed when rotating the shaft end due to the impact from inertia factor and magnetic attraction effect.
- (4) Please check the consistency for power, voltage, current and rpm in motor nameplate.

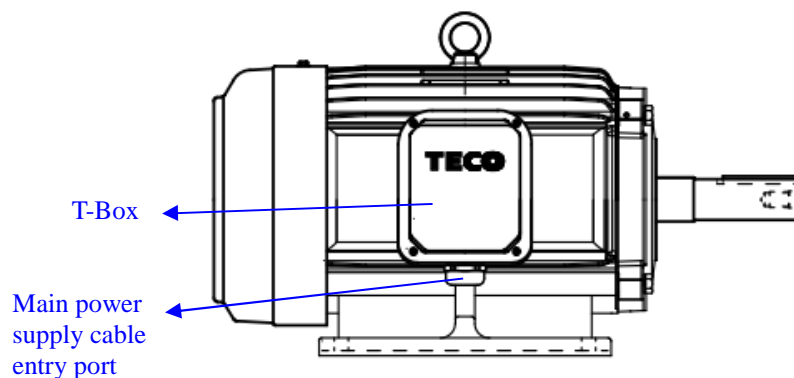

Figure 1 Motor profile

2 Installation

2.1 Installation location

- (1) Please install the motor at a well-ventilated place so that the motor-generated heat will not be recycled from the air exhaust side to the air suction side. For a higher ambient temperature, to use a corresponding heat dissipation and thermal insulation device is recommended.
- (2) Please maintain a spacing over 10-cm distance between the air inlet of cooling fan and the outer wall.
- (3) Please install the motor at a low humidity area.
- (4) Dust is easy to accumulate in the radiator of the frame, which reduces the cooling effect and leads to overheating; please clean it regularly.
- (5) If the environment for motor installation contains acidic, alkaline chemicals, and explosive special gases; using a motor with explosion-proof structure should be considered.
- (6) Please install motor at a workplace where is easy for disassembly, check, cleaning and maintenance.
- (7) Please install motor at a jobsite with lower voltage fluctuation of power supply.
- (8) Please use permanent magnet motor drives that meet the specifications. If you have any doubts about the match of drives, please contact our company and service staff of our distributor.

3. Wiring

3.1 Junction box

Permanent magnet motors need to be driven by permanent magnet motor drives. The name of each contact is marked inside the T-box. Please follow the correct marking for wiring connection.

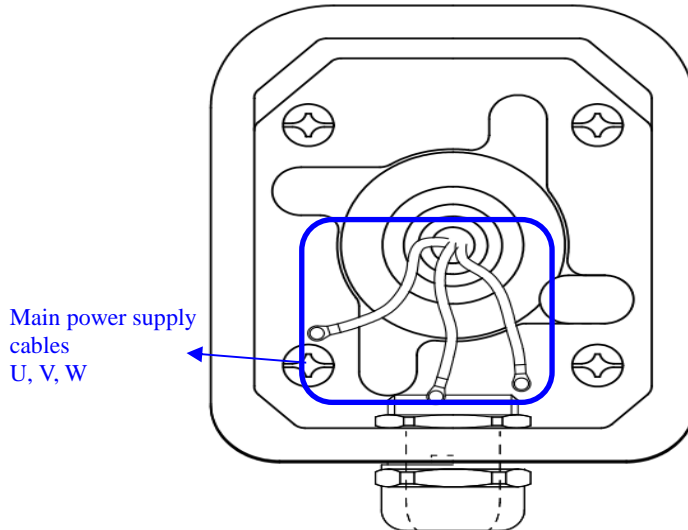

Figure 2 T-box layout diagram

3.2 Rotating direction

- (1) Please confirm if the rotating direction is correct.
- (2) The rotating direction of the motor is confirmed by observation from shaft end direction at load side; if change of rotating direction is desired, please adjust it from the drives.
- (3) Please confirm that the airflow direction of cooling fan is from the fan side toward the motor side (shaft end).

3. Commissioning and operation

1. Before operation

All motors have been strictly tested prior to their ex-factory; however, owing to the possible impacts arising from long-term storage or transportation against motor status, please check and validate motor status before use.

- (1) Precautions before commissioning:
 - ① Are power supply wirings correctly connected? Is external cover of T-box normally accessorized and locked?
 - ② Are anchor bolts loosened?
 - ③ Is there any improper ventilation condition?
 - ④ Is there occurrence of contact friction problem between rotating parts and stationary parts when manually rotating the shaft end?

- ⑤ Disconnect the main circuit of motor and measure the insulation resistance of stator coil to ground by using a 500VDC high resistance meter to connect the main power supply terminal of the motor and the grounding terminal; the insulation resistance to ground should be above 5MΩ as the standard.
 - ⑥ Are the grounding terminals of each part totally connected?
- (2) Lubrication
The motor is mounted non-oil-charging type bearings that needs no oil charging.
- (3) Others
In the case of direct coupling or belt pulley connection, it is necessary to check if the bolts and nuts at each part are locked properly.

2. Operation

- (1) To operate the motor for the first time, please test it at low-speed without load and check the following items after startup:
- ① Is rotating direction correct?
 - ② Is there any unusual noise at bearing assembly?
 - ③ Is there any abnormal noise inside the motor?
 - ④ Is there burnt smell around the surrounding?
 - ⑤ Is there any abnormal vibration? If yes, please take necessary check actions to identify the cause.
 - ⑥ Is three-phase equilibrium available from the input voltage and phase current of power supply?
- (2) If there is no abnormality detected from the abovementioned conditions, please connect motor to its load device, perform the no-load operation and full-load operation, and check again according to the above items.

4. Maintenance and checks

In order to prevent equipment from occurring the operation accidents, to carry out the routine records and checks is a must.

1. Routine checks

To start and operate the motor, please check the equipment status to ensure that there is no occurrence of abnormal vibration or unusual noise with the routine records maintained.

Items for routine check and record:

- (1) Date measured, time, weather
- (2) Ambient temperature
- (3) Voltage, load current, frequency, rpm

- (4) Temperature of stator winding or frame
- (5) Bearing temperature and bearing sound
- (6) Is there any abnormal vibration or unusual noise?
- (7) Is cooling fan for motor running normally?

Bearing is introduced a double shielded bearing (bearing model number is suffixed “ZZ”) for motor, which is oil pre-charging type that needs no further oil charging. Please periodically check if there is any unusual noise or abnormal vibration at the bearing; if yes, shut down the machine immediately for repair and maintenance.

Please regularly check the motor and maintain a clean motor exterior to avoid obstruction of foreign materials from affecting the heat dissipation. Cooling fan blades and filters shall be cleaned to ensure that ventilation opening will not be blocked to affect air flow.

2. Periodic checks

- (1) Insulation resistance measurement
- (2) Bearing status inspection
- (3) Ventilation status
- (4) Vibration measurement
- (5) Are screws fastened tightly?
- (6) Coupling status/belt tension for direct-coupling motor
- (7) Cleaning each part
- (8) Power state

It is suggested that the insulation resistance should be checked every six months, and other items should be checked annually. In addition, the vibration of the machine can be monitored regularly. This step is very crucial to the detection of abnormality at beginning stage. An excessive vibration may be generated from the factors of bearings, windings or coupling status, etc. to cause adverse effects; an immediate investigation shall be followed to eliminate the causes.

3. Fitting checks

For motor with fittings of electromagnetic brake or gear reducer mounted, if any, please refer to their respective instruction manual for checks.

5. Storage

For a motor that its use is not wanted for an extended period of time or for more than 3 months, please refer to the methods for handling its storage:

- (1) Please store it at a dry area and cover it with protective device.
- (2) Machined surfaces: Shall be smeared antirust agent every 6 months.
- (3) Rotating shaft: Shall be smeared antirust agent every 3 months (or before long-term preservation) and covered with protection cover to protect shaft end from collision damage.
- (4) Winding insulation resistance: When the motor has not been running for a long time, please measure the winding-ground insulation resistance every 6 months and prior to its operation. For a measured insulation resistance less than $100M\Omega$, please perform a drying treatment for the winding.

6. Disassembly and assembly

There are permanent magnets mounted inside the motor rotor, which has certain dangerousness and risk of damage for its disassembly. Therefore, user's disassembling the motor is prohibited. For any problem or question, please contact our company and service staff of each distributor.

7. Troubleshooting

For any abnormal conditions arising from general, routine and periodic checks, please refer to Table 2 Checklist for troubleshooting.

Table 2 Motor Troubleshooting Checklist

Possible causes			Symptoms	Shaft damaged	Noise/excessive vibration	Overheating		Irregular rotation	Protector triggered	Electric leakage	Faulty insulation resistance	Handling methods
						Body	Bearing					
Installation	Place	Ambient temperature too high			<input type="radio"/>	<input type="radio"/>		<input type="radio"/>				Improve ventilation system
		Humidity too high							<input type="radio"/>	<input type="radio"/>		Consult manufacturer
		Grease or water internally accumulated				<input type="radio"/>				<input type="radio"/>	<input type="radio"/>	Remove
		Insufficient space around motor			<input type="radio"/>	<input type="radio"/>			<input type="radio"/>			Remove unnecessary articles
		External vibration, excessive impact		<input type="radio"/>		<input type="radio"/>					<input type="radio"/>	Antivibration treatment
Unstable installation platform				<input type="radio"/>							Reinforce platform strength	
Load coupling	Direct coupling	Improper center alignment	<input type="radio"/>	<input type="radio"/>		<input type="radio"/>						Redo center alignment
		Coupling's amount of unbalance too big		<input type="radio"/>								Calibrate the coupling
	Pulley	Pulley center misaligned		<input type="radio"/>			<input type="radio"/>					Redo center alignment
		Contact angle too small	<input type="radio"/>			<input type="radio"/>						Select suitable outside diameter of pulley
		Tension too strong	<input type="radio"/>			<input type="radio"/>						Adjust belt tension
		Load point distant from motor too far	<input type="radio"/>			<input type="radio"/>						Move load point to be nearby motor side
	Others	Over-size pulley hinders ventilation for heat dissipation			<input type="radio"/>			<input type="radio"/>				Build air duct for heat dissipation of pulley
		Dirt stained to rotating part		<input type="radio"/>		<input type="radio"/>						Cleaning exterior
	Axial load too big				<input type="radio"/>						Review the axial force	
	Wiring	Excessive voltage drop			<input type="radio"/>		<input type="radio"/>	<input type="radio"/>				Wiring length is too long, adjust the length
Terminal loosened					<input type="radio"/>		<input type="radio"/>	<input type="radio"/>			Refasten terminals	
Incomplete grounding connection								<input type="radio"/>	<input type="radio"/>		Redo grounding connection	
Single-phase operation			<input type="radio"/>	<input type="radio"/>				<input type="radio"/>			Check connecting circuits	
Voltage imbalance			<input type="radio"/>	<input type="radio"/>				<input type="radio"/>			Check control side	
Incorrect wiring of cooling fan				<input type="radio"/>	<input type="radio"/>						Recheck loops	

Wrong wiring of thermistor							<input type="radio"/>			Recheck wirings
----------------------------	--	--	--	--	--	--	-----------------------	--	--	-----------------

Possible causes		Symptoms	Shaft damaged	Noise/excessive vibration	Overheating		Irregular rotation	Protector triggered	Electric leakage	Faulty insulation resistance	Handling methods
					Body	Bearing					
Load	Overload		<input type="radio"/>	<input type="radio"/>				<input type="radio"/>			Reduce load
	Acceleration / deceleration time too fast	<input type="radio"/>		<input type="radio"/>				<input type="radio"/>			Increase acceleration / deceleration time
	Load inertia too big			<input type="radio"/>				<input type="radio"/>			Increase acceleration time
	Excessive equipment vibration at load side		<input type="radio"/>								Perform mechanical investigation
	Load's amount of unbalance too big		<input type="radio"/>		<input type="radio"/>						Redo balance operation
Others	Faulty bearing		<input type="radio"/>		<input type="radio"/>			<input type="radio"/>			Return factory for inspection & repair
	Winding coil broken		<input type="radio"/>	<input type="radio"/>				<input type="radio"/>	<input type="radio"/>	<input type="radio"/>	Return factory for inspection & repair
	Abnormal noise of cooling fan, wire broken		<input type="radio"/>	<input type="radio"/>	<input type="radio"/>	<input type="radio"/>	<input type="radio"/>	<input type="radio"/>			Replace cooling fan

8. Maintenance service

1 Free repair warranty period

The warranty period is 1 year starting from the day of customer's receiving the product delivered from the factory.

2 Scope of warranty

2.1 Fault diagnosis

User may follow Table 2 to proceed troubleshooting for a preliminary diagnosis at the time of failure. For any problem, if any, please contact our company and distributors. No additional fees will be charged for a general consultation.

2.2 Fault maintenance

If the motor is damaged due to the following circumstances, additional fees may be charged for its repair and maintenance:

- ① Damage caused by repair or modification that is made by a company other than the TECO-designated companies.
- ② Damage caused by force majeure factors, such as natural disasters, fires.
- ③ The cause of the failure is not attributed to TECO.
- ④ Product warranty period is expired.

3 Repair after stopping production

For products that are stopped their production, the feasibility to repair them will be determined according to the existing situation; and a notice will be issued separately if they are unrepairable. We thank you for your understanding.

TECO Electric & Machinery Co., Ltd.

10F, No. 3-1, Park Street, Nangang District, Taipei City, Taiwan, R.O.C.

TEL: (02) 6615-9111

FAX: (02) 6616-2503

(02) 6616-2082

Web: <http://www.teco.com.tw>

<http://www.tecomotor.com.tw>