

11

10

9

8

7

6

5

4

3

2

1

POLE	HP	kW	Hz	VOLT	r/min(RPM)	INS	RATING	DIMENSION IN	APPROX WEIGHT	BEARINGS
4	350	.	60	460	1800	F	CONT.	INCH	3186 LB	DE: 6320 NDE: 6316

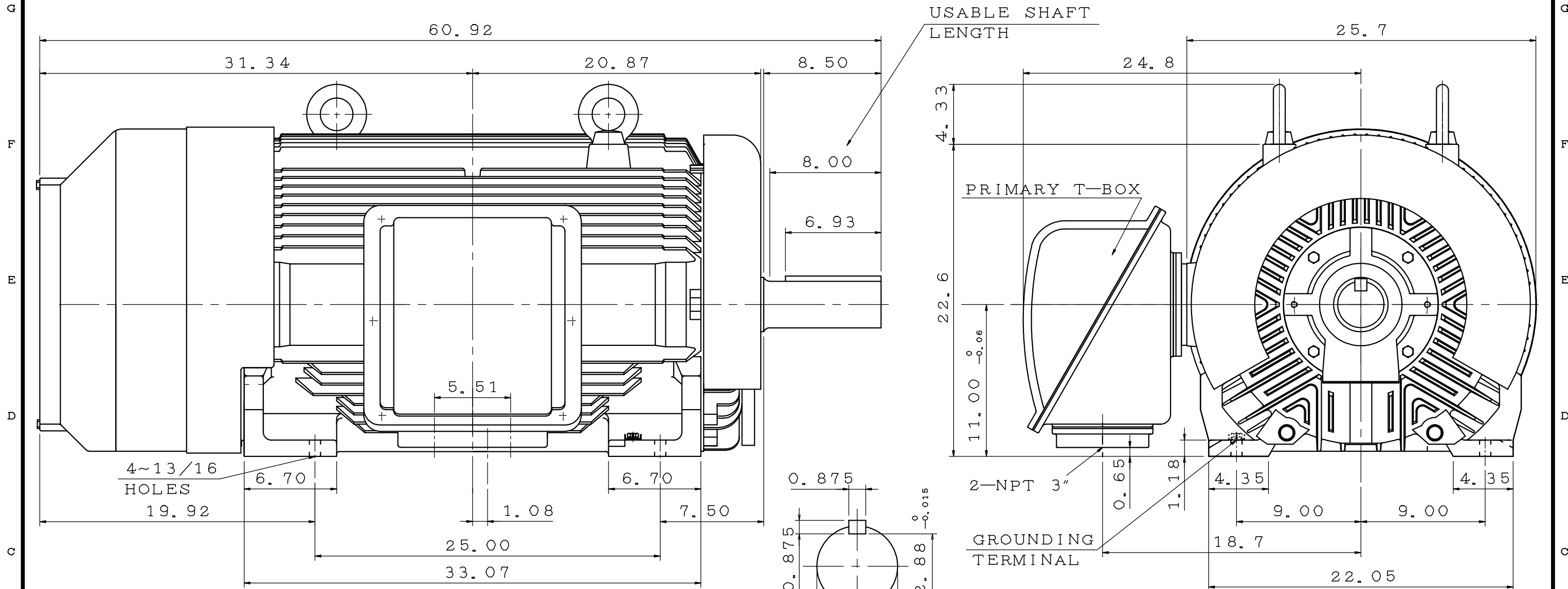

- NOTE:
1. FOR DIRECT FLEXBLE COUPLING
  2. ENCLOSURE: IP55 PROTECTION
  3. NON-SPARKING FAN

SHAFT END  
ENLARGED VIEW

OUTLINE DIMENSIONS 3-PHASE INDUCTION MOTOR			
MOTOR TYPE	AEHH8N-11-	FRAME NO.	449T(X)
CUSTOMER	.	DATE	.
ORDER NO.	.	TRANS. SHEET	.
<b>TECO</b> <b>Westinghouse</b>			DWG NO. 31057C578540

APPD.	M. C. JENG	01.21.20
CHKD.	M. C. JENG	01.21.20
DWG.	H. S. Hsu	01.21.20

第三角法

11

10

9

8

7

6

5

4

3

2

1

ISSUED 19-Mar-14	<b>PERFORMANCE DATA</b> 3-PHASE SQUIRREL CAGE HIGH EFFICIENCY INDUCTION MOTOR	MODEL <b>AEHH8N-□□□</b>
REVISED 12-Oct-20		



TEFC, NEMA T-FRAME, DESIGN - B, ee C C 0 0 2 A  
 CLASS F, 40°C AMBIENT, CONTINUOUS DUTY,  
 S.F. 1.15 460V 60Hz

**TYPICAL PERFORMANCE (460 V)**

HP	FULL LOAD RPM	FRAME SIZE	EFFICIENCY(%)				POWER FACTOR(%)			CURRENT			TORQUE				ROTOR WK <sup>2</sup> lb-ft <sup>2</sup>	NEMA CODE LETTER	APPROX. WEIGHT LBS
			FULL LOAD		3/4 LOAD	1/2 LOAD	FULL LOAD	3/4 LOAD	1/2 LOAD	FULL LOAD (A)	208V USABLE ON-A	LOCKED ROTOR (A)	FULL LOAD lb-ft	LOCKED ROTOR %FLT	PULL UP %FLT	BREAK DOWN %FLT			
			NOM.	MIN.	NOM.	NOM.													
60	3550	364TS	94.1	93.0	94.5	94.1	93.0	92.0	88.5	64.2	142	435	88.74	145	130	240	7.379	G	782
	1775	364T	95.0	94.1	95.0	94.5	86.5	83.0	75.5	68.4	151	435	177.5	200	155	240	12.23	G	800
	1180	404T	94.5	93.6	94.5	94.1	87.0	86.5	80.5	68.3	151	435	267.0	200	185	245	33.54	G	1261
	885	405T	93.0	91.7	93.6	93.6	81.0	78.0	68.0	74.6	165	435	356.0	200	180	230	32.55	G	1356
75	3555	365TS	94.5	93.6	95.0	95.0	93.0	92.5	89.0	79.9	177	543	110.8	145	130	250	9.056	G	841
	1775	365T	95.4	94.5	95.4	95.0	86.5	83.5	75.5	85.1	188	543	221.9	200	165	250	14.67	G	936
	1180	405T	94.5	93.6	94.5	94.5	86.5	84.5	79.0	85.9	190	543	333.7	200	175	225	37.86	G	1356
	885	444T	93.6	92.4	93.0	91.7	79.0	76.0	67.0	95.0	210	543	445.0	130	110	210	55.10	G	1467
100	3560	405TS	95.4	94.5	95.8	95.4	92.0	91.5	88.5	107	236	725	147.5	140	125	270	10.77	G	1233
	1775	405T	95.4	94.5	95.4	95.0	87.5	85.5	80.0	112	248	725	295.8	215	140	215	26.64	G	1301
	1181	444T	95.0	94.1	94.5	93.6	82.5	80.0	73.0	119	264	725	444.6	140	110	230	56.00	G	1575
	885	445T	93.6	92.4	93.0	91.7	79.0	76.5	68.0	127	280	725	593.3	130	110	210	72.80	G	1718
125	3563	444TS	95.0	94.1	94.5	93.6	86.0	83.5	80.0	143	317	910	184.2	110	88	220	16.60	G	1498
	1780	444T	95.4	94.5	95.0	94.1	85.0	83.0	77.0	144	319	910	368.7	130	100	220	44.30	G	1619
	1182	445T	95.0	94.1	94.5	93.6	83.0	80.5	74.0	148	328	910	555.3	140	110	230	68.00	G	1795
	888	447T	94.1	93.0	93.6	92.1	80.0	77.0	69.0	155	344	910	739.1	120	100	200	141.0	G	2026
150	3566	445TS	95.0	94.1	94.5	93.6	87.0	84.5	81.0	170	---	1085	220.9	110	88	220	20.00	G	1588
	1783	445T	95.8	95.0	95.4	94.5	85.0	83.0	78.0	172	---	1085	441.7	130	100	220	52.00	G	1703
	1185	447T	95.8	95.0	95.4	94.5	83.5	81.0	74.0	176	---	1085	664.6	135	105	220	103.0	G	2059
	888	449T	94.1	93.0	93.6	92.1	80.0	77.0	69.0	187	---	1085	886.9	120	100	200	166.0	G	2281
200	3572	447TS	95.4	94.5	95.0	94.1	89.0	85.0	81.0	221	---	1450	294.0	104	83	210	32.00	G	1916
	1785	447T	96.2	95.4	95.8	95.0	87.0	83.5	78.5	224	---	1450	588.3	120	95	210	73.50	G	2004
	1186	449T	95.8	95.0	95.4	94.5	84.0	81.0	74.0	233	---	1450	885.4	135	105	210	125.0	G	2272
	888	449T	94.5	93.5	94.1	93.0	80.0	77.0	69.0	248	---	1450	1183	120	100	200	221.0	G	2598
250	3575	449TS	95.8	95.0	95.4	94.5	89.8	86.0	82.0	272	---	1825	367.2	103	83	210	44.00	G	2132
	1787	449T	96.2	95.4	95.8	95.0	88.0	84.5	80.0	277	---	1825	734.5	110	90	210	83.00	G	2312
	1188	449T	95.8	95.0	95.4	94.5	84.5	82.0	74.5	289	---	1825	1105	110	90	210	140.0	G	2466
300	3580	449TS	95.8	95.0	95.4	94.5	90.2	86.5	82.5	325	---	2200	440.0	102	81	210	52.50	G	2312
	1788	449T	96.2	95.4	95.8	95.0	88.0	84.5	80.0	332	---	2200	881.0	100	85	210	107.0	G	2532
	1188	449T	95.8	95.0	95.4	94.5	84.5	82.0	74.5	347	---	2200	1326	100	85	210	199.0	G	2708
	1188	449T(X)	95.8	95.0	95.4	94.5	84.5	81.0	73.0	347	---	2200	1326	150	120	250	199.0	G	3130
350	3583	449TS	95.8	95.0	95.4	94.5	90.2	86.5	82.5	379	---	2550	512.9	102	81	210	62.00	G	2826
	1788	449T	96.2	95.4	95.8	95.0	88.0	84.5	80.0	387	---	2550	1028	100	85	210	124.00	G	2937
	3579	449TS(X)	95.8	95.0	96.4	95.7	91.0	87.5	83.0	372	---	2350	513.5	120	100	300	57.40	G	3000
1789	449T(X)	96.2	96.2	96.2	95.7	89.0	86.5	80.0	384	---	2450	1027	150	130	350	126.0	G	3186	
400	3575	449TS	95.8	95.0	95.7	95.5	91.0	90.0	89.0	429	---	2900	587.5	160	130	300	64.60	G	2930
	1785	449T	96.2	95.4	96.0	95.8	84.0	82.0	79.0	460	---	2900	1177	140	110	300	135.0	G	3080
	3576	449TS(X)	95.8	95.0	96.0	95.5	88.5	87.5	83.0	438	---	2600	587.3	160	130	300	69.77	G	3045
	1788	449T(X)	96.2	95.4	96.4	96.1	88.9	86.8	80.9	437	---	2900	1175	140	120	350	146.3	G	3342

- NOTE :
- The above are typical values based on test according to ANSI/IEEE standard 112 method B.
  - Breakdown & locked rotor torques are shown as average expected values.
  - Efficiency, power factor, speed and torque are the same for other voltages.  
Current values vary inversely with voltage.
  - Tolerance according to NEMA MG1-12 & IEC 60034-1.
  - Data subject to change without notice.

APPD.	Jason Wang	23-Oct-20	<b>TECO Electric &amp; Machinery Co., Ltd.</b>	DWG. NO.	<b>31057D98649</b>
CHKD.	Shian.Jeng	23-Oct-20		REV. 05	
DWN.	C.T. CHEN	15-Apr-20		2/2	

**TECO**

# CONNECTION DIAGRAM

MODEL

DATE :  
DEC.04.'02

For  $\Delta/\Delta$  connection

DAC-1545-1

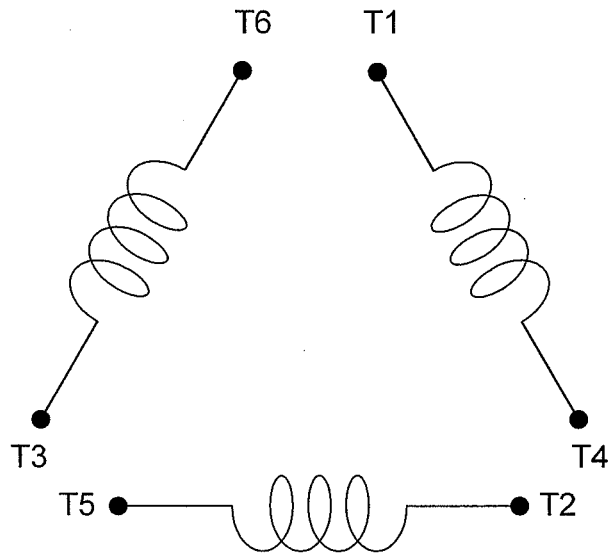

**SCHEMATIC -  $\Delta/\Delta$  CONNECTION**

## ROTATION

(VIEWED FROM DRIVE END)



## CONNECTION

$\Delta-\Delta$  START

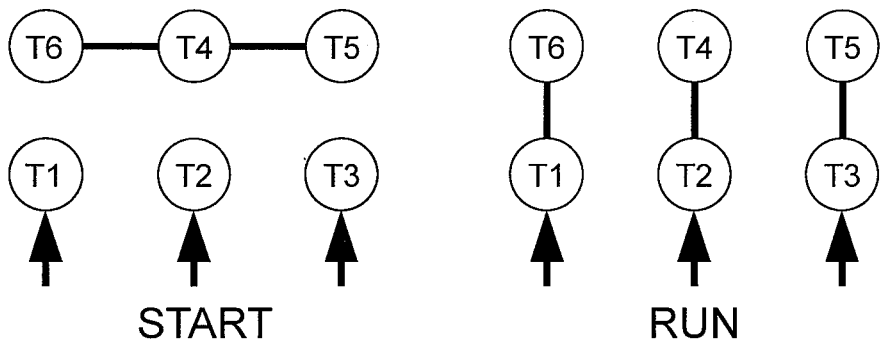

ACROSS-THE-LINE



承 認		
審 核	蔡	Dec.05.02
校 對	林	Dec.04.02
繪 製	林賢龍	DEC,04,'02

**東元電機股份有限公司**  
**TECO ELECTRIC & MACHINERY CO., LTD.**  
 TAIWAN R.O.C.

圖 號：  
**DAC-1545-1**



# **INSTALLATION AND MAINTENANCE INSTRUCTIONS FOR THREE PHASE INDUCTION MOTORS**

Frames 143T - 449TZ



5100 North IH 35 Round Rock, Texas 78681

## RECEIVING

1. Check nameplate data.
2. Check whether any damage has occurred during transportation.
3. After removal of shaft clamp, turn shaft by hand to check that it turns freely.
4. If motor is to be reshipped (alone or installed to another piece of equipment) the shaft must again be clamped to prevent axial movement.

Note: Remove the bearing clamp before turning the shaft on 284T-449TZ frame motors.

## WARNING

### THE FOLLOWING SAFETY PRECAUTIONS MUST BE OBSERVED:

1. Electric rotating machinery and high voltage can cause serious or fatal injury if improperly installed, operated or maintained. Responsible personnel should be familiarized with NEMA MG-1; Safety Standards for Construction and Guide Selection. Installation and Use of Electric Motors and Generators; National Electric Code and all local safety requirements.
2. When servicing, all power sources to the motor and to the accessory devices should be de-energized and disconnected and all rotating parts should be at standstill.
3. Lifting means, when supplied, are intended for lifting the motor only. When two lifting devices are supplied with the motor a dual chain must be used.
4. Suitable protection must be used when working near machinery with high noise levels.
5. Safeguard or protective devices must not be by-passed or rendered inoperative.
6. The frame of this machine must be grounded in accordance with the National Electric Code and applicable local codes.
7. A suitable enclosure should be provided to prevent access to the motor by other than authorized personnel. Extra caution should be observed around motors that are automatically or have automatic re-setting relays as they may restart unexpectedly.
8. Shaft key must be fully captive or removed before motor is started.
9. Provide proper safeguards for personnel against possible failure of motor-mounted brake, particularly on applications involving overhauling loads.
10. Explosion proof motors are constructed to comply with the label service procedure manual, repair of these motors must be made by TECO-Westinghouse Motor Company or U/L listed service center in order to maintain U/L listing.

## LOCATION

1. Drip-proof motors are intended for use where atmosphere is relatively clean, dry, well ventilated and non-corrosive.
2. Totally enclosed motors may be installed where dirt, moisture, or dust are present and in outdoor locations.
3. Explosion-proof motors are built for use in hazardous locations as indicated by Underwriters' label on the motor.
4. Chemical duty enclosed motors are designed for installation in high corrosion or excessive moisture locations.

**Note: in all cases, no surrounding structure should obstruct normal flow or ventilating air through or over the motor.**

## MOUNTING

1. Mount motor securely on a firm, flat base. All ball bearing normal thrust motors up to and including 256T frame size may be side-wall or ceiling mounted; all others check nearest TECO-Westinghouse office for mounting recommendations.
2. Align motor accurately, using a flexible coupling if possible. For drive recommendations, consult with drive or equipment manufacturer, or TECO-Westinghouse.
3. Mounting bolts must be carefully tightened to prevent changes in alignment and possible damage to the equipment. The recommended tightening torque's for medium carbon steel bolts, identified by three radial lines at 120 degrees on the head, are:

Bolt Size	Recommended Torque (Ft-lb.)	
	Minimum	Maximum
2/8	25	37
1/2	60	90
5/8	120	180
3/4	210	320

4. V-belts Sheave Pitch Diameters should not be less than those shown in Table 1 (NEMA recommended values)
5. Tighten belts only enough to prevent slippage. Belt speed should not exceed 5000 ft. per min.

**TABLE 1. V-Belt Sheave Pitch Diameters (MG1-14.42)**

Frame Number					V-Belt Sheave			
					Conventional A, B, C, D AND E		Narrow 3V, 5V, AND 8V	
	Horsepower at				Minimum Pitch Diameter Inches	*Maximum Width Inches	Minimum Outside Diameter Inches	**Maximum Width Inches
	Synchronous Speed, RPM							
3600	1800	1200	900					
143T	1.5	1	.75	.5	2.2	4.25	2.2	2.25
145T	2-3	1.5-2	1	.75	2.4	4.25	2.4	2.25
182T	3	3	1.5	1	2.4	5.25	2.4	2.75
182T	5	...	...	...	2.6	5.25	2.4	2.75
184T	...	...	2	1.5	2.4	5.25	2.4	2.75
184T	5	...	...	...	2.6	5.25	2.4	2.75
184T	7.5	5	...	...	3.0	5.25	3.0	2.75
213T	7.5-10	7.5	3	2	3.0	6.5	3.0	3.375
215T	10	...	5	3	3.0	6.5	3.0	3.375
215T	15	10	...	...	3.8	6.5	3.8	3.375
254T	15	...	7.5	5	3.8	7.75	3.8	4
254T	20	15	...	...	4.4	7.75	4.4	4
256T	20-25	...	10	7.5	4.4	7.75	4.4	4
256T	...	20	...	...	4.6	7.75	4.4	4
284T	...	...	15	10	4.6	9	4.4	4.625
284T	...	25	...	...	5.0	9	4.4	4.625
286T	...	30	20	15	5.4	9	5.2	4.625

**TABLE 1. V-Belt Sheave Pitch Diameters (MG1-14.42)**

Frame Number					V-Belt Sheave			
					Conventional A, B, C, D AND E		Narrow 3V, 5V, AND 8V	
	Horsepower at				Minimum Pitch Diameter Inches	*Maximum Width Inches	Minimum Outside Diameter Inches	**Maximum Width Inches
	Synchronous Speed, RPM							
3600	1800	1200	900					
324T	...	40	25	20	6.0	10.25	6.0	5.25
326T	...	50	30	25	6.8	10.25	6.8	5.25
364T	...	...	40	30	6.8	11.5	6.8	5
364T	...	60	...	...	7.4	11.5	7.4	5.785
365T	...	...	50	40	8.2	11.5	8.2	5.785
365T	...	75	...	...	9.0	11.5	8.6	5.785
404T	...	...	60	...	9.0	14.25	8.0	7.25
404T	...	...	...	50	9.0	14.25	8.4	7.25
404T	...	100	...	...	10.0	14.25	8.6	7.25
405T	...	...	75	60	10.0	14.25	10.0	7.25
405T	...	100	...	...	10.0	14.25	8.6	7.25
405T	...	125	...	...	11.5	14.25	10.5	7.25
444T	...	...	100	...	11.0	16.75	10.0	8.5
444T	...	...	...	75	10.5	16.75	9.5	8.5
444T	...	125	...	...	11.0	16.75	9.5	8.5
444T	...	150	...	...	...	16.75	10.5	8.5
445T	...	...	125	...	12.5	16.75	12.0	8.5
445T	...	...	...	100	12.5	16.75	12.0	8.5
445T	...	150	...	...	...	16.75	10.5	8.5

\*Max. Sheave width = 2(N-W) - .25

\*\*Max Sheave width = N-W

\*\*\*Sheave ratios greater than 5:1 and center-to-center distance less than the diameter of the large sheave should be referred to TECO-Westinghouse.

## POWER SUPPLY & CONNECTIONS

1. Wiring of motor and control, overload protection and grounding should be in accordance with National Electrical Code and all local safety requirements.
2. Nameplate voltage and frequency should agree with power supply. Motor will operate satisfactorily on line voltage within  $\pm 10\%$  of nameplate voltage; or frequency with  $\pm 5\%$  and with a combined variation not to exceed  $\pm 10\%$ . 230-volt motors can be used on 208-volt network systems, but with slightly modified performance characteristics as shown on the nameplate.
3. Dual voltage and single voltage motors can be connected for the desired voltage by following connection diagram shown on the nameplate or inside of the conduit box.
4. All Explosion Proof motors have Temperature Limiting Devices in the motor enclosure to prevent excessive external surface temperature of the motor in accordance with U/L standards. Terminals of thermal protectors (P1 & P2) should be connected to the motor control equipment, according to the connection diagram inside of the conduit box.
5. Standard connection diagram for three phase, not thermally protected, dual rotation motors are shown in diagrams A through E. **(Note: To change rotation, Interchange any two line leads)**

**A. 3 Lead, Single Voltage**



**B. 6 Lead, Dual Voltage & Voltage Ratio 1 to 3**

**B-1 Across the Line Start & Run**



**B-2 Wye Start & Delta Run  
(Low Voltage only)**



**C. 9 Leads; Dual Voltage & Voltage Ratio 1 to 2, Wye Connected**

**C-1 Across the Line Start & Run**



**C-2 Part Winding Start  
(Low Voltage only)**



### D. 9 Leads; Dual Voltage & Voltage Ratio 1 to 2, Delta Connected

D-1 Across the Line Start & Run



D-2 Part Winding Start (Low Voltage only)



### E. 12 Leads, Dual Voltage

E-1 Across the Line Start & Run



E-2-1 Wye Start & Delta Run (Low Voltage only)



E-2-2 Wye Start & Delta Run (High Voltage only)



### E-3 Part Winding Start (Low Voltage only)



\*Important: For Part Winding Start, M2 contactor should be closed within two (2) seconds after M1 contactor is closed.  
Only 4 pole and above (e.g., 6P, 8P...) motors are satisfactory for Part Winding Start at low voltage.

### START UP

1. Disconnect load and start motor. Check direction of rotation. If rotation must be changed, ALLOW THE MOTOR TO STOP COMPLETELY. Interchange any two leads of a three-phase motor.
2. Connect load. The motor should start quickly and run smoothly. If no, shut power off at once. Recheck the assembly including all connections before restarting.
3. If excessive vibration is noted, check for loose mounting bolts too flexible motor support structure or transmitted vibration from adjacent machinery. Periodic vibration checks should be made; foundations often settle.
4. Operate under load for short period of time and check operating current against nameplate.

### TESTING

If the motor has been in storage for an extensive period or has been subjected to adverse moisture conditions, it is best to check the insulation resistance of the stator winding with a megometer. Depending on the length and conditions of storage it may be necessary to regrease or change rusted bearings.

If the resistance is lower than one megohm the windings should be dried in one of the following two ways:

1. Bake in oven at temperatures not exceeding 194°F until insulation resistance becomes constant.
2. With rotor locked, apply low voltage and gradually increase the current through windings until temperature measured with a thermometer reaches 194°F. Do not exceed this temperature.

## MAINTENANCE

### INSPECTION

Inspect motor at regular intervals. Keep motor clean and ventilation openings clear.

### LUBRICATION

1. Frame 143T-256T: Double shielded and pre-lubricated ball-bearing motors without grease fittings and don't need re-lubrication, except on MAX-E1<sup>®</sup> and MAX-E2<sup>®</sup> products which have re-greasable features.
2. Frames 280TS, 320-449TZ(TS): Motors having grease fittings and grease discharge devices at brackets. Motors are shipped with grease for initial running. It is necessary to re-lubricate anti-friction bearing motors periodically, depending on size and type of service. See Table 2 to provide maximum bearing life. Excessive or too frequent lubrication may damage the motor.

**TABLE 2**

Horsepower	Standard Conditions	Severe Conditions	Extreme Conditions
1 Thru 30 Hp, 1800 rpm and below	7 years	3 years	180 days
40 Thru 75 Hp, 1800 rpm and below	210 days	70 days	30 days
100 Thru 150 Hp, 1800 rpm and below	90 days	30 days	15 days
1 Thru 20 Hp, 3600 rpm	5 years	2 years	90 days
25 Thru 75 Hp, 3600 rpm	180 days	60 days	30 days
100 Thru 150 Hp, 3600 rpm	90 days	30 days	15 days

Note:

- A. Standard conditions: 8 hours operation per day, normal or light loading, clear and 40°C ambient conditions.
  - B. Severe conditions: 24-hour operation per day or light shock loading, vibration or in dirty or dusty conditions.
  - C. Extreme conditions: With heavy shock loading or vibration or dusty conditions.
  - D. For double shielded bearings, above data (lubrication frequency) means that the bearing must be replaced.
3. Be sure fittings are clean and free from dirt. Using a low-pressure grease gun, pump in the recommended grease until new grease appears at grease discharge hole.
  4. Use the POLYUREA grease unless special grease is specified on the nameplate.
  5. If re-lubrication is to be performed with the motor running, stay clear of rotating parts. After re-greasing, allow the motor to run for ten to thirty minutes.

## **RENEWAL PARTS**

1. Use only genuine TECO-Westinghouse renewal parts or as recommended by TECO-Westinghouse Motor Company.
2. When you order renewal parts please specify complete information to TECO-Westinghouse office/agent such as type, frame no., poles, horsepower, voltage, series no., quantity, etc.

**FOR FURTHER INFORMATION PLEASE CONTACT  
TECO-WESTINGHOUSE MOTOR COMPANY**

**Round Rock, TX**

**800-873-8326**