

TYPE	OUTPUT		POLE	TIME RATING	VOLTAGE V	Hz	SYN. SPEED R. P. M
	HP.	KW.					
AEJH-TK	900		2	CONT.	2300/4160	60	3600

TOTALLY ENCLOSED FAN-COOLED TYPE, SQUIRREL-CAGE ROTOR

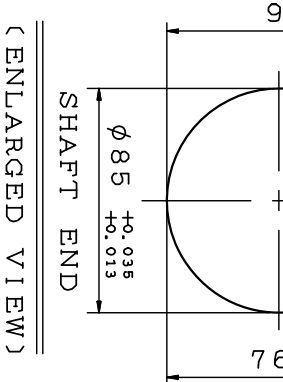
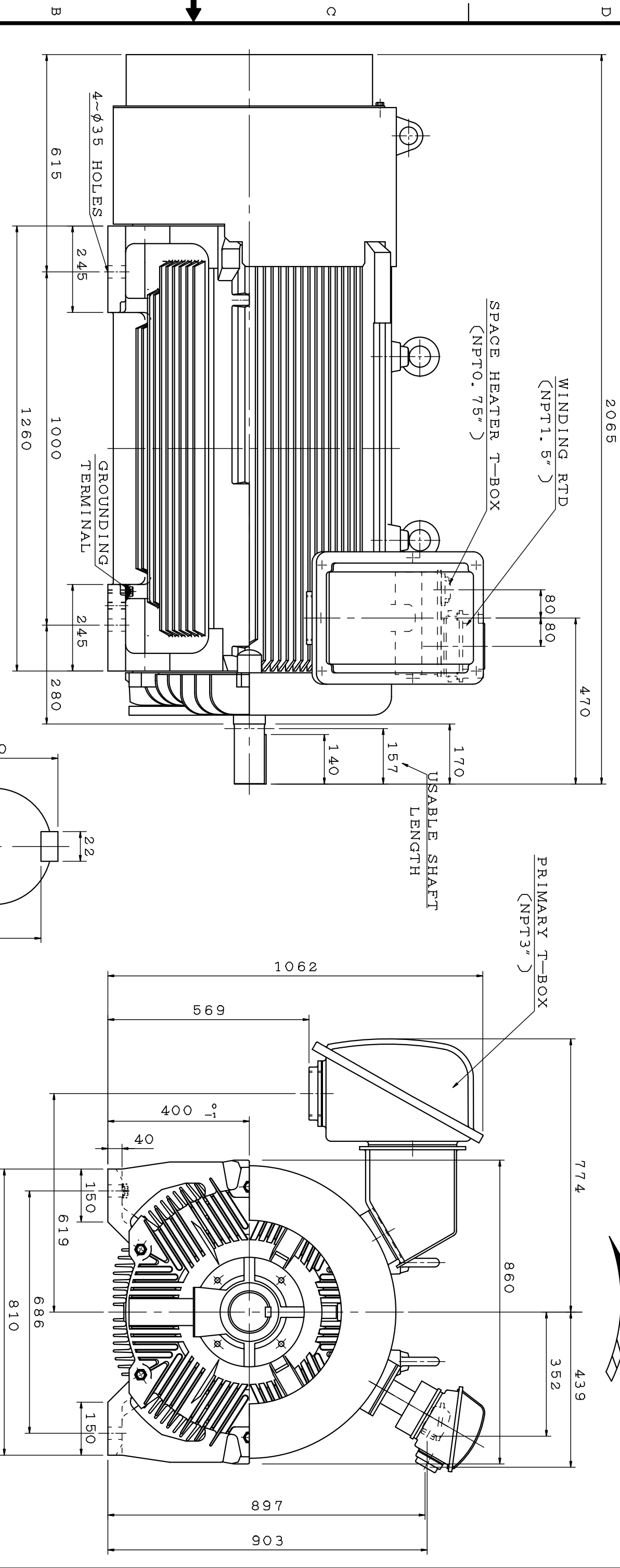

- NOTE:
1. DIMENSIONS IN MM
  2. FRAME NO. 400CA
  3. F CLASS INSULATION
  4. FOR DIRECT FLEXIBLE COUPLING
  5. ENCLOSURE: IP54
  6. BEARING SIZE: DRIVE-END 6318C3  
OPP. DRIVE-END 6315C3
  7. WITH WINDING RTD: PT 100Ω/0°C 6PCS
  8. WITH SPACE HEATER: 1φ 120V 250W
  9. APPROX. WEIGHT: 7780 LBS

DWN.	R. SHEN	FEB•22•2010
CHKD.	C. FU	FEB•23•2010
APPD.	B. YANG	FEB•24•2010

DATE	OUTLINE DIMENSIONS
	3-PHASE INDUCTION MOTOR
<b>TECO</b> Westinghouse	
DWG NO.	REV:00
3 B040Y306	



項	A
01	NPT - 0.75"
02	
03	
04	
05	
06	
07	
08	
09	
10	
11	



- NOTE:
1. DIMENSIONS IN INCHES [MM].
  2. TW-06
  3. SPACE HEATER T-BOX.
  4. ENCLOSURE:IP55.

DATE \_\_\_\_\_

SCHEMATIC DRAWING

TERMINAL BOX

DWN.	HHUANG	JUL - 19 - 2003
CHKD.	HHUANG	JUL - 19 - 2003
APPD.	C.WANG	JUL - 19 - 2003



DWG NO. 3A040U272

REV: 02

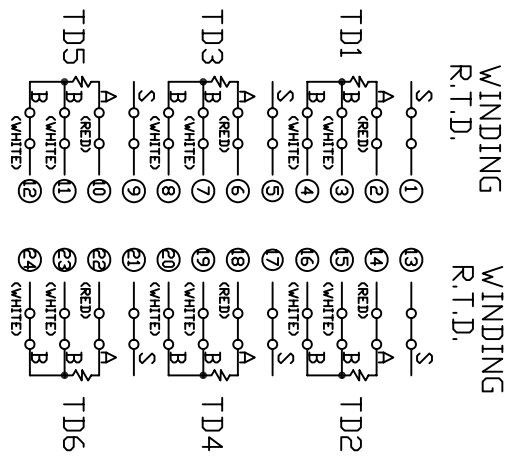

- NOTE:
1. DIMENSION IN MILLICINCHES.
  2. TW-36
  3. WINDING R.T.D. T-BOX.
  4. TD1 & TD2 FOR UKA) PHASE  
TD3 & TD4 FOR V(B) PHASE  
TD5 & TD6 FOR W(C) PHASE.
  5. ENCLOSURE:IP55

ITEM	A
01	NPT-1.5"
02	
03	
04	
05	
06	
07	
08	
09	
10	
11	
12	

DATE \_\_\_\_\_  
 SCHEMATIC DRAWING  
 TERMINAL BOX

DWN.	S. WANG	MAR-26-1999
CHKD.	J.PENG	MAR-29-1999
APPD.	A.WU	MAR-29-1999

**TEG Westinghouse**  
 D/WG NO. 3A040D418  
 REV:09

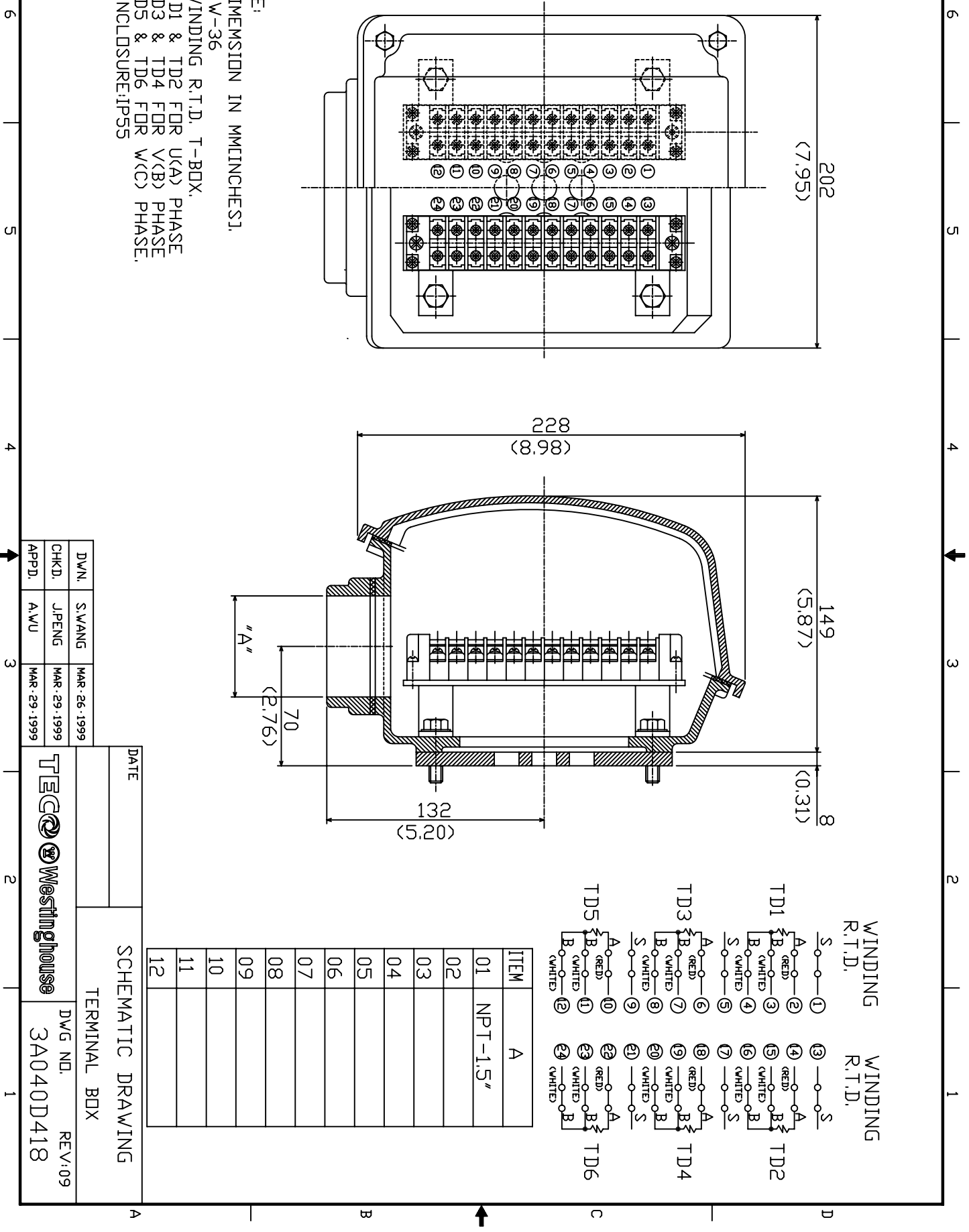

# TECO Westinghouse

ISSUED <b>April 29, 2010</b>	<b>PERFORMANCE DATA</b>	ENCLOSURE <b>TEFC</b>
TYPE <b>AEJHTK</b>	<b>3-PHASE INDUCTION MOTOR</b>	CATALOG# <b>JF09002</b>

### NAMEPLATE INFORMATION

OUTPUT		POLE	FRAME SIZE	VOLTAGE	HZ	RATED AMBIENT	INS. CLASS	NEMA DESIGN	TIME RATING	SERVICE FACTOR
HP	KW									
<b>900</b>	<b>671</b>	<b>2</b>	<b>400CA</b>	<b>2300/4160</b>	<b>60</b>	<b>40°C</b>	<b>F</b>	<b>B</b>	<b>CONT.</b>	<b>1.15</b>

### TYPICAL PERFORMANCE

FULL LOAD RPM	EFFICIENCY				POWER FACTOR			MAXIMUM POWER FACTOR CORRECTION
	FULL LOAD		3/4 LOAD %	1/2 LOAD %	F. L. %	3/4 LOAD %	1/2 LOAD %	
	MIN. %	NOM. %						
<b>3577</b>	<b>95.2</b>	<b>96</b>	<b>95.8</b>	<b>95.2</b>	<b>89.7</b>	<b>88.5</b>	<b>84.2</b>	<b>181 KVAR</b>

### CURRENTS

NO LOAD		FULL LOAD		LOCKED ROTOR		NEMA KVA CODE LETTER
AT	AT	AT	AT	AT	AT	
2300 VOLT	4160 VOLT	2300 VOLT	4160 VOLT	2300 VOLT	4160 VOLT	
<b>45.30</b>	<b>25.10</b>	<b>196.00</b>	<b>108.00</b>	<b>1540.00</b>	<b>851.00</b>	<b>G</b>

### TORQUE

### INERTIA

### ACCEL TIME

FULL LOAD lb-ft	LOCKED ROTOR %FLT	PULL UP %FLT	BREAK DOWN %FLT	ROTOR WR <sup>2</sup> lb-ft <sup>2</sup>	NEMA LOAD WK <sup>2</sup> lb-ft <sup>2</sup>	MAX ALLOWABLE WK <sup>2</sup> lb-ft <sup>2</sup>	NEMA LOAD WK <sup>2</sup> Sec	MAX ALLOWABLE WK <sup>2</sup> Sec
<b>1313.00</b>	<b>116</b>	<b>104</b>	<b>220</b>	<b>225</b>	<b>615</b>	-	<b>6.00</b>	-

SAFE STALL TIME IN SECONDS

ALLOWABLE STARTS PER HOUR

SOUND PRESSURE LEVEL @ 3 FT dB(A)

SAFE STALL TIME IN SECONDS		ALLOWABLE STARTS PER HOUR		SOUND PRESSURE LEVEL @ 3 FT dB(A)
COLD	HOT	COLD	HOT	
<b>20</b>	<b>15</b>	<b>2</b>	<b>1</b>	-

APPROVED:

**M. PRATER**

DRAWING NO.

**3A057JF09002**

REV. **1**

DATE  
NOV.22.2010

SCHEMATIC  
6 LEADS

MODEL

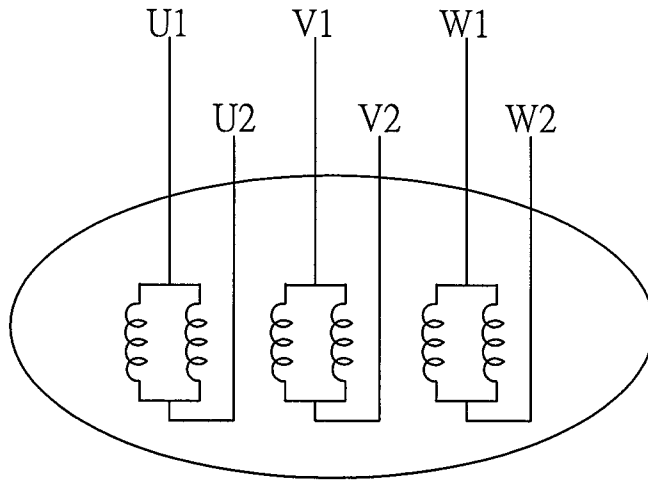

SCHEMATIC DIAGRAM - 6 LEADS

VOLTAGE	CONNECTION	ROTATION ( VIEWED FROM DRIVE END )
LOW	<p>Diagram showing a star (Y) connection. Three horizontal lines at the top are labeled R, S, and T. The bottom terminals of the windings are connected to a central point. The bottom terminals are labeled U1, U2, V1, V2, W1, and W2.</p>	<p>A curved arrow indicating clockwise rotation when viewed from the drive end.</p>
HIGH	<p>Diagram showing a delta (Δ) connection. Three horizontal lines at the top are labeled R, S, and T. The windings are connected in a closed loop. The bottom terminals are labeled U1, U2, V1, V2, W1, and W2.</p>	<p>A curved arrow indicating clockwise rotation when viewed from the drive end.</p>

DWN.	S.HUANG	MAR · 03 · 2003
CHKD.	T.HSIAO	MAR · 03 · 2003
APPD.	T.HSIAO	MAR · 03 · 2003

**TECO** **Westinghouse**

DWG NO. REV: 00

3 A 0 6 1 H 4 7 7



# Instructions For Three Phase Induction Motors

Large Cast Iron Frame Type  
IEC Frame 280 (NEMA Frame 444) and above

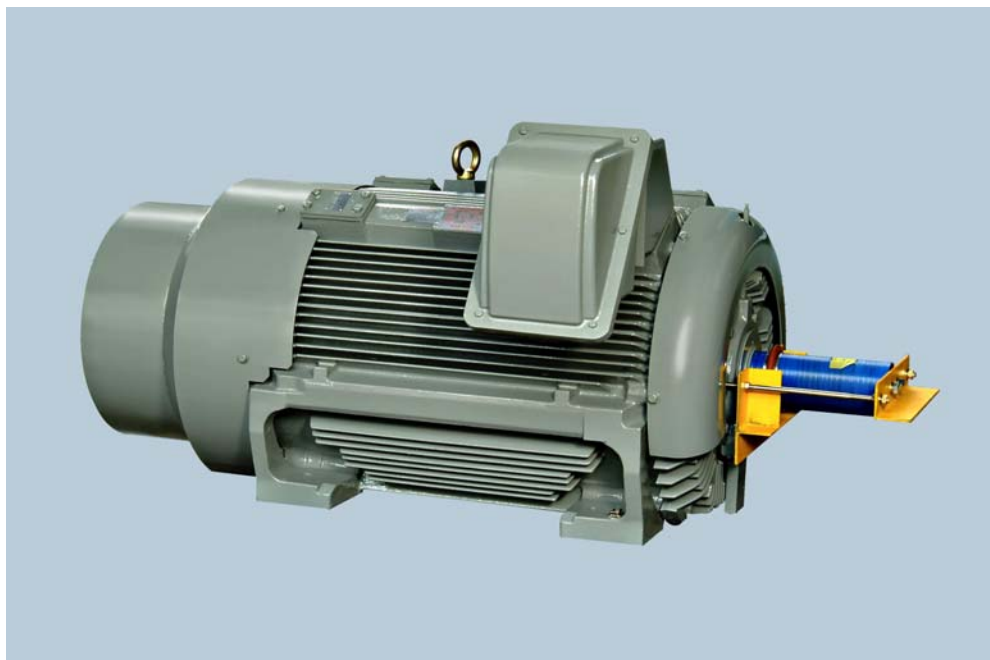

## INDEX

Page

---

<b>1. INTRODUCTION.....</b>	<b>3</b>
<b>1.1 General.....</b>	<b>3</b>
<b>1.2 Serial number of the machine .....</b>	<b>4</b>
<b>1.3 Mounting.....</b>	<b>4</b>
<b>1.4 Direction of rotation.....</b>	<b>4</b>
<b>2. ACCEPTING, INSPECTION, STORAGE, TRANSPORTATION .....</b>	<b>5</b>
<b>2.1 Inspection upon receipt .....</b>	<b>5</b>
<b>2.2 Storage.....</b>	<b>5</b>
<b>2.3 Transportation.....</b>	<b>10</b>
<b>3. INSTALLATION.....</b>	<b>11</b>
<b>3.1 Site and environment for motor installation .....</b>	<b>11</b>
<b>3.2 Foundation.....</b>	<b>11</b>
<b>3.3 Installation of shaft coupling.....</b>	<b>14</b>
<b>3.4 Installation for belt drive.....</b>	<b>19</b>
<b>3.5 Conveyance with chain or gear .....</b>	<b>20</b>
<b>3.6 Electrical connections .....</b>	<b>21</b>
<b>4. OPERATION.....</b>	<b>23</b>
<b>4.1 Examination before start.....</b>	<b>23</b>
<b>4.2 Starting operation .....</b>	<b>29</b>
<b>5. MAINTENANCE .....</b>	<b>34</b>
<b>5.1 Major points in regular inspection and maintenance .....</b>	<b>34</b>
<b>5.2 Motor windings .....</b>	<b>35</b>
<b>5.3 Clean the interior of the motor .....</b>	<b>35</b>
<b>5.4 Clean the exterior of the motor.....</b>	<b>36</b>
<b>5.5 Maintenance of anti-friction bearing .....</b>	<b>38</b>
5.5.1 Frequency of relubrication.....	38
5.5.2 Kinds of grease.....	38
5.5.3 Grease quantity .....	40
5.5.4 Re-greasing .....	40
5.5.5 Oil relubrication (For oil lubrication types only).....	41
5.5.6 Cleaning and installation of bearings.....	42
<b>5.6 Maintenance of sleeve bearing .....</b>	<b>43</b>
5.6.1 Daily inspections.....	43
5.6.2 Regular examination .....	43
5.6.3 Disassembly .....	44
5.6.4 Reassembly .....	45

---

---

5.6.5 Oil viscosity for vertical motors .....	46
<b>5.7 Maintenance of slip ring (For Wound Rotor only) .....</b>	<b>47</b>
<b>5.8 Maintenance of non-reverse ratchet mechanism .....</b>	<b>49</b>
<b>5.9 Dismantling and Assembly Procedure .....</b>	<b>50</b>
<b>5.10 Records of operation and maintenance.....</b>	<b>51</b>
<b>6. FAULT FINDING AND RECOGNITION.....</b>	<b>52</b>
<b>7. RECYCLE.....</b>	<b>54</b>
<b>Appendix 1. Daily inspection .....</b>	<b>57</b>
<b>Appendix 2. Monthly inspection.....</b>	<b>58</b>
<b>Appendix 3. Regular Inspection .....</b>	<b>59</b>
<b>Appendix 4. Typical motor cross sectional drawings : SCIM, TEFC.....</b>	<b>62</b>
<b>Appendix 5. Typical motor cross sectional drawings : ODP .....</b>	<b>63</b>
<b>Appendix 6. Typical motor cross sectional drawings : SCIM, TEWC .....</b>	<b>64</b>
<b>Appendix 7. Typical ball bearing construction drawing .....</b>	<b>65</b>
<b>Appendix 8. Typical roller bearing construction drawing .....</b>	<b>66</b>
<b>Appendix 9. Typical ball bearing with insulation bushing construction drawing .....</b>	<b>67</b>
<b>Appendix 10. Typical thrust bearing assembly drawing (vertical machine) .....</b>	<b>68</b>
<b>Appendix 11. Sleeve bearing construction .....</b>	<b>69</b>
<b>Appendix 12. Mounting of Insulated Sleeve Bearings.....</b>	<b>71</b>
<b>Appendix 13. Shaft earth brush assembly drawing (Type I).....</b>	<b>72</b>
<b>Appendix 14. Shaft earth brush assembly drawing (Type II).....</b>	<b>73</b>
<b>Appendix 15. Bolt Torque (kg-cm) .....</b>	<b>74</b>
<b>Appendix 16. TECO Worldwide Operations.....</b>	<b>75</b>

---

---

## 1. INTRODUCTION

### 1.1 General

This and the following instructions address the more common situations encountered in motor installation, operation and maintenance. For the TECO motor warranty to be and to remain in effect, the motor must be installed and operated in strict accordance with the outline drawing, motor nameplates and these instructions, and must not be altered or modified in any unauthorized manner.

During the installation and operation of motors in heavy industrial applications there is a danger of contact with live electrical and rotating parts. Therefore to prevent injury and/or damage the basic planning work for installation, transport, assembly, operation, etc.... needs to be done and checked by authorized and competent personnel only.

Since these instructions cannot cover every eventuality of installation, operation and maintenance, the following points should however be considered and checked.

- Technical data and information on permissible use such as assembly, connection, ambient and operating conditions given in the related catalogue, operating instructions, nameplates and other production documentation.
- General erection and safety regulations.
- Local (job site) and plant-specific specifications and requirements.
- Proper use of transport, lifting devices and tools.
- Use of personal protective equipment.

**The following safety indications should be observed when reading these instructions:**



**Electric Hazard.**



**Danger.**

#### **ATTENTION !**

**Warning of possible damage to the motor or installation.**

This instruction manual is for **TECHNICAL USE ONLY, NOT FOR COMMERCIAL PURPOSE**. The warranty is limited to coverage expressed in your sales contract. Documentation of storage, transportation, installation and examination, if required, shall be obtained from TECO-Westinghouse service centers before start and maintenance.

---

## 1.2 Serial number of the machine

Each electric motor is identified with a serial number. It has been stamped on a main name plate which is attached on the frame by rivets. This serial number is very important as an index for tracking this motor's history.

## 1.3 Mounting

In this instruction manual, the arrangements for most of the electric motor are as follows:

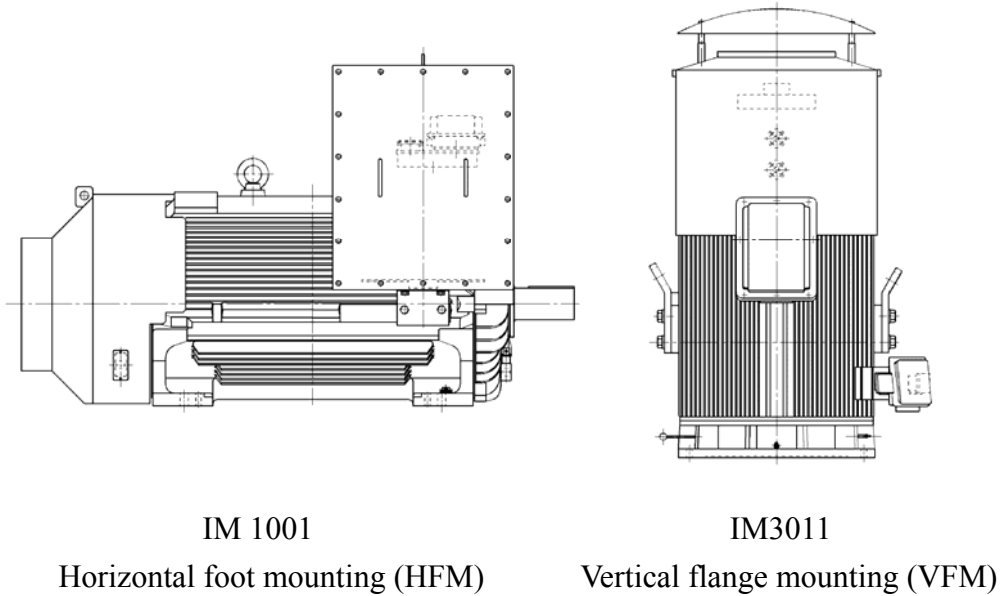
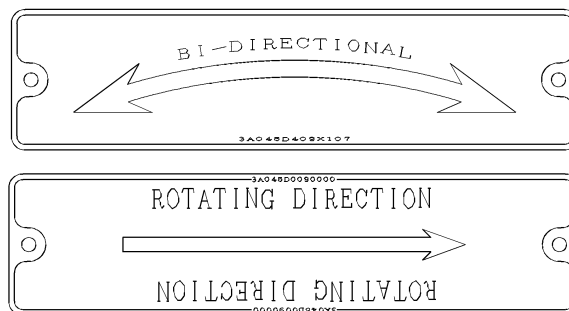

**Fig. 1 Mounting arrangement**

## 1.4 Direction of rotation

The arrow on the direction nameplate indicates the direction of the rotation of the Rotor, looking in front of the DE-Shaft-end.

The motor must be operated just on the plate shown direction.



**Fig. 2 Direction nameplate**

### **ATTENTION !**

**Operating the motor in the incorrect direction may cause serious damage to both the motor and driven equipment.**

---

## 2. ACCEPTING, INSPECTION, STORAGE, TRANSPORTATION

### 2.1 Inspection upon receipt

Check the following points upon receipt :

- Is there any visible damage to the motor or case? Any damage should be photographed, documented and reported to the carrier and TECO-Westinghouse immediately.
- Are the nameplate ratings identical with your confirmed order ?
- Are dimensions and color in compliance with your specifications ?
- Are the nameplate ratings for heater, thermal protector, temperature detector, etc. identical with your confirmed order ?
- Are all accessories and accompanying instruction manuals in good order ?
- Does the arrow head indicate the correct direction of rotation?
- If there are any specific requirements, please ensure they are in conformity with your specification.

### 2.2 Storage

#### 2.2.1 General

When motors are not in operation, the following precautionary measures must be taken to insure the motors do not suffer deterioration or damage from moisture, dust and dirt, or careless handling. The climate, length of time the equipment is to be stored, and the adequacy of the storage facilities will determine the storage precautions required.

Any deterioration or damage of the motors due to customer's incorrect storage of the motors is not covered by the warranty. This includes all periods of time when the motor is installed on site but has not been placed into operation.

The following procedures must be followed and a maintenance log must be kept to keep from voiding factory warranty. The records are also useful to decide if a motor is suitable or not to be put into service.

#### 2.2.2 Location

The ideal storage area is a clean, heated, and well-ventilated building.

- (a) High and dry, well-ventilated indoor, without exposure to direct sun lights, free from dust, corrosive gas (such as chlorine, sulfur, dioxide, and nitrous oxides) and fumes, and infestation by vermin or insects.
  - (b) The ideal storage temperature range is from 10°C to 50°C (50°F to 125°F)
  - (c) Not close to a boiler or freezer.
  - (d) Entirely free from vibration. Vibration levels above 2.5 mm/s (0.1 in/sec) velocity could damage the bearings and cause "brinelling" of the bearing races.
  - (e) Motors should be put on pallets to prevent moisture from accumulating underneath.
  - (f) Motors should be stored in a heated building, outdoor storage is not suitable for motors. If motors have to be stored outdoors for some reasons, they should be well covered with a tarpaulin and protected from contamination and the elements. Motors should be well shielded from dust, but under well-ventilated circumstances. This should be for a very short period of time (say less than one month) only and the risk of deterioration is the responsibility of the users.
-

### 2.2.3 Moisture prevention

Since moisture can be very detrimental to electrical components, the motor temperature should be maintained about 3°C above the dew point temperature by providing either external or internal heat. If the motor is equipped with space heaters, they should be energized at the voltage shown by the space heater nameplate attached to the motor. Check weekly that the space heaters are operating. Incandescent light bulbs can be placed within the motor to provide heat, if the anti-condensation space heaters are not fitted. However, if used, incandescent bulbs must not be allowed to come in contact with any parts of the motor because of the concentrated hot spot that could result.

### 2.2.4 Prevent Corrosion and frost damage

When motors are shipped from the factory, the shaft extension and bearing journals on sleeve bearing motors, are covered with a protective coating. This coating should be examined to see that it has not been accidentally removed. The coating should be renewed if there are any signs of corrosion or if the coating has been removed. Care should be taken to keep parts such as fitted surface, key, shaft extension, mounting feet or face, and axial central hole from any collision with foreign matters, and to have rust preventative in place. It is a good practice to seal any shaft openings with silicone, rubber caulking, or tape. If any rust is observed, measures should be taken to remove the rust and protect against it. Grease or anti-corrosion agent should also be generously applied to prevent rusting.

Water-cooled motors or motors using bearings with water-cooling coils, please make sure the water is dried off to prevent tube corrosion or frost damage.

TECO-Westinghouse reserves the right to void warranties based upon evidence of rust or other indications of moisture inside the motor that indicate that the motor was improperly stored.

### 2.2.5 Insulation resistance test

Even during storage, the insulation resistance should be kept above the specified values.

- (a) For measurement of insulation resistance and acceptable standard values, please refer to measures stated in 4.1.2 "Measurement of insulation resistance".
- (b) Insulation resistance test should be performed once every three months.
- (c) Resistance measurement of each temperature detector (ex. PT 100Ω/°C) is necessary once every three months.

### 2.2.6 Long period of idle (storage)

If the motor is not in operation for a long period of time (one week and above) after installation or has been in operation but stopped for a period of time, the following precautions must be taken.

- (a) Protect the motor as measures stated in 2.2.3 and 2.2.4.
  - (b) Insulation resistance test should be performed as stated in 2.2.5.
  - (c) Bearing Protection per 2.2.7.
  - (d) Operation test should be performed once every three (3) months.
-

- (e) If external vibration is present, the shaft coupling should be opened.
- (f) If motors are mounted shaft up, a solid protective plate or shield shall be mounted above the installation if needed.
- (g) If motors are mounted shaft down, drip covers are to be mounted to give satisfactory protection if needed.
- (h) If motors are equipped with drain plugs, they should be removed.
- (i) When motors equipped with brushes, the brushes should be lifted in the brush holder, if there is no protective strip (such as MYLAR) between the brushes and collector rings.
- (j) Water-cooled motors or motors using bearings with water-cooled coils, ensure the water is dried off to prevent tube corrosion or frost damage.
- (k) Storage maintenance must be documented for warranty and reference purposes.

### 2.2.7 Bearing protection

- (a) If the motor has been provided with a shaft shipping brace to prevent shaft movement during transit, it must be removed before operating the motor.  
It is very important that this brace be reinstalled exactly as it was originally, before the motor is moved from storage or any time when the motor is being transported. This prevents axial rotor movement that might damage the bearings.

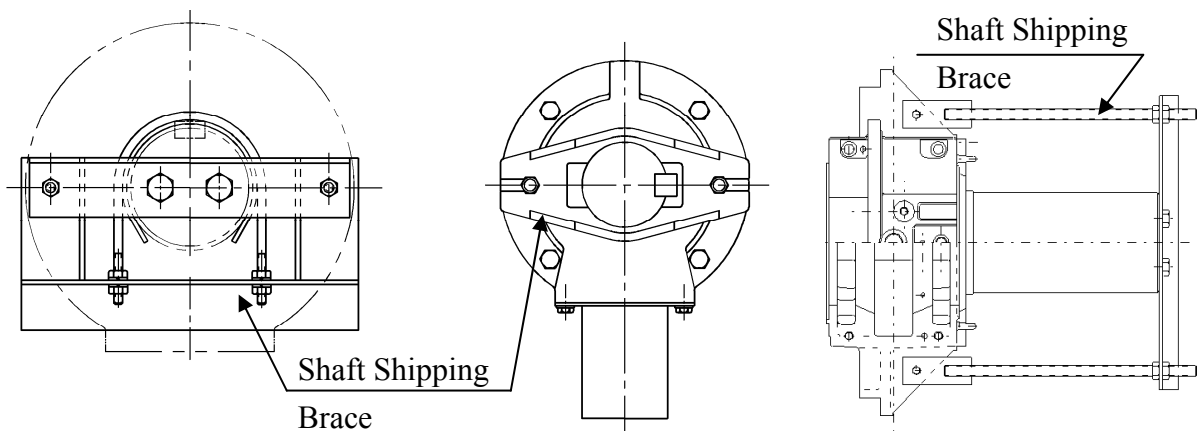

**Fig. 3 Shaft shipping brace**

- (b) Motors equipped with sleeve bearings are shipped from the factory with the bearing oil reservoirs drained. In storage, the oil reservoirs should be properly filled to the center of the oil level gauge with a good grade of rust inhibiting oil. To keep the bearing journals well oiled and prevent rusting, the motor shaft should be rotated several revolutions every month ensuring the shaft does not come to rest in its original position. While the shaft is rotating, it should be pushed to both extremes of the endplay. If the motor is not in operation for over six months, dismount the upper cover of the sleeve bearing housing and check the anti-corrosion protection.

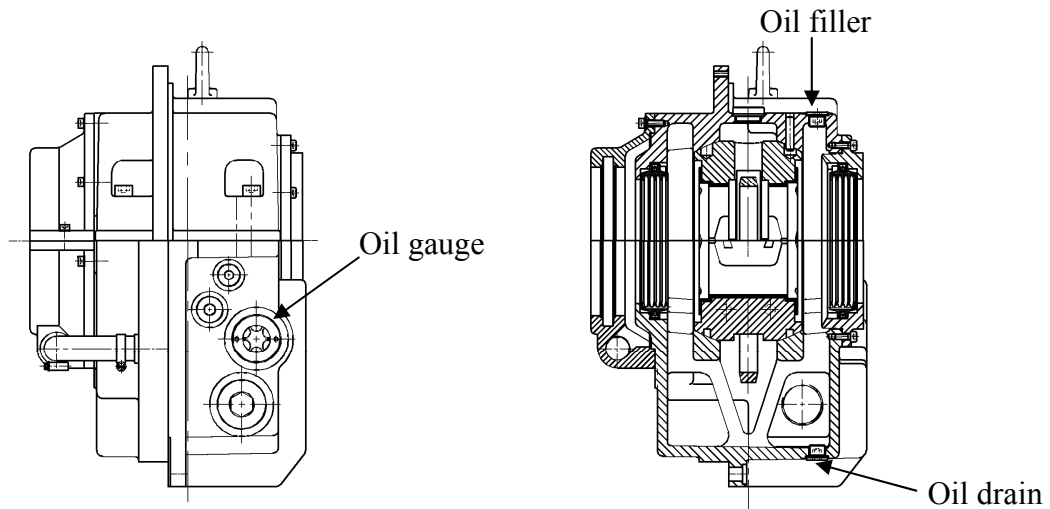

**Fig. 4 Sleeve bearing**

- (c) Motors with anti-friction bearings are properly lubricated with the correct grade of grease at the factory and no further greasing is required in storage. If the motor is not in operation for over three months, add grease to each bearing per lubrication nameplate. The shaft should be rotated several revolutions every month to maintain proper distribution of the grease within the bearings.
- (d) Tilt-pad bearings are a type of sleeve bearing used in special design applications. Due to the nature of this bearing, a loose oil ring for delivering lubricant cannot be provided. Therefore, during the storage interval, oil must be manually introduced periodically into the pads and housing to prevent the occurrence of oxidation of the precision machined components.
- (1) Remove the pipe plug from the bearing cap located above the tilt-bearing shell.
  - (2) Pour in approximately one cup of oil every month and rotate the shaft a few revolutions every two (2) weeks.
- For long periods of storage, the oil that accumulates in the housing should be removed.
- (e) The bearing assembly parts of motors with oil mist lubrication are put on with anti-rust oil, so they can be preserved for several months in good condition. The motor should be stored indoor and well-ventilated environment and prevent contact with contaminated or corrosive air. The following points should be noted :

- (1) During preservation, the Inpro seal can not prevent moisture from going through into the bearings. Please use the oil mist to lubricate the bearings every two (2) weeks.
  - (2) If the color of flow out oil is changed, the bearing should be rusted or have contamination in it. Please contact TECO-Westinghouse.
  - (3) Avoid using grease as it will plug the vent/drain.
  - (4) All assembly surfaces are painted with seal bonds, do not disassemble them at anytime.
  - (5) Do not remove the plugs in vent/drain to prevent the moisture.
  - (6) Do not apply any force on the Inpro seal to prevent damage.
  - (7) The Inpro seal is a labyrinth type seal. Therefore it can not contain a pressure differential.
- (f) If the storage is over two (2) years, it is recommended that the bearing assembly is dismantled and the bearing parts are inspected before commissioning. Any corrosion has to be removed with fine emery cloth.
- (g) Motors with anti-friction bearings with provisions for oil mist are shipped from factory with the correct grade of grease in the bearings and therefore it is not necessary to hook up the motors to the oil mist system. The shaft should be rotated several revolutions every month to maintain proper distribution of the grease within the bearings. If customers choose to hook up to the oil mist system, all grease must be removed from the bearings.

### **2.2.8 Removal from storage**

After long period of idle or storage, and, prior to energizing the motor, a thorough inspection and megger test of windings is required. The bearings should be inspected for corrosion, brinelling and deformation.

If any of the following conditions pertain, then re-conditioning may be required before putting a motor into service.

- (a) Winding resistance is less than recommended.
- (b) Evidence of rust or other indications of moisture inside the motor.
- (c) Corrosion or brinelling or deformation occurred in bearings.
- (d) Idle or storage longer than the warranty period.
- (e) Idle or storage in dirty or damp surroundings.
- (f) Storage in unheated area where the temperature and humidity fluctuate.
- (g) Idle or storage where it has been subject to vibration, such as from nearby machinery or passing traffic.
- (h) Outdoor storage.
- (i) No maintenance records showing that the storage procedures have been followed.

Any reconditioning required, as noted by the inspections after removal from storage, should be performed prior to putting the motor into service. Such inspection and testing or re-conditioning are available from local TECO-Westinghouse service/facilities. Reconditioning after idle or storage is not covered by factory warranty. Any parts that must be replaced due to damage or deterioration will be at customer's cost.

---

## 2.3 Transportation

### ATTENTION !

To keep the rotating parts of motors from moving, thus preventing damage and scratching during transportation, they should be held securely with a locking device. Remove all transit clamps before operating the motor. It is very important that this device be reinstalled, exactly as it was originally, before the motor is moved from storage or any time when the motor is being transported.

Vertical mount type motors should be transported in the vertical position only.



Do not use the hoisting hook/eyebolts to lift more than the motor itself. They are designed to support the motor only.

Make sure the hoisting hook is correctly attached to the eyebolt(s) or lug(s) of the motor and that the eyebolt(s)/lug(s) are fully threaded in before hoisting. Also note such parts as fan cover, ventilation box, bracket, slip-ring covers, etc. may have their own hoisting lugs which can only carry their own weight. Nothing extra should be attached while hoisting.

Do not twist or cross the steel cables. Make sure the eyebolts have been securely threaded with the shoulder flush and the sling angle is correct.

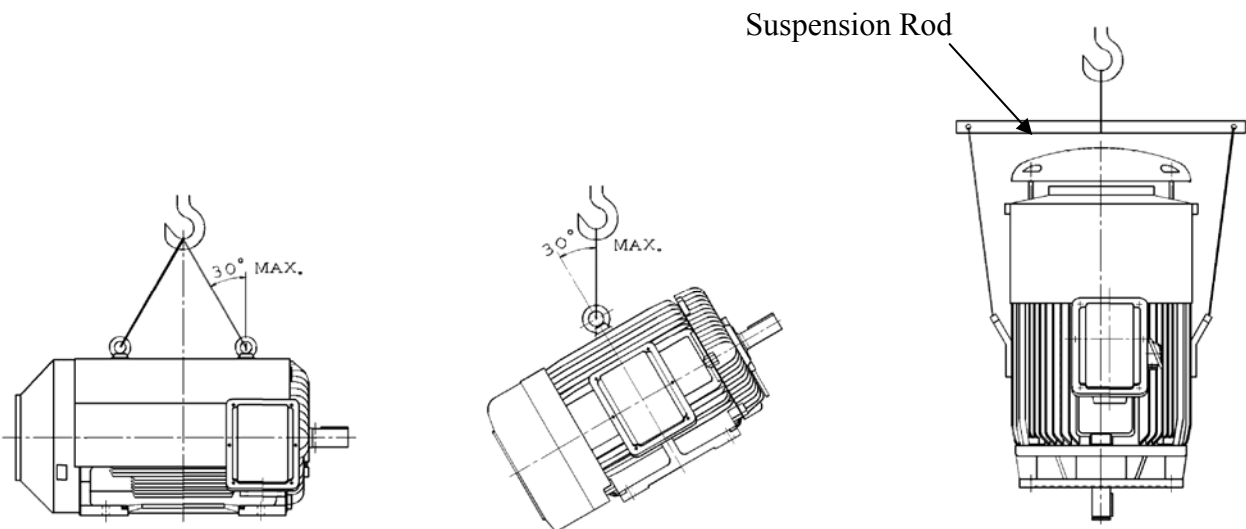

Fig. 5

### 3. INSTALLATION

#### 3.1 Site and environment for motor installation

##### 3.1.1 General

Standard environment and site conditions for the installation of motors are usually set as follows :

- (a) Ambient temperature :  $-20 \sim +40$  °C
- (b) Humidity : Relative humidity shall be below 95%RH for totally-enclosed types, and below 80%RH for semi-enclosed types.
- (c) Elevation : Below 1000 meters.
- (d) Harmful gases, liquids, dusts and high moisture levels should be absent.
- (e) Foundations should be strong and free of vibration.

For water-cooled motors or motors using bearings with water-cooling coils, the ambient temperature must not drop below 5°C (41°F) to prevent frost damage. If there are any special environmental conditions, please inform us at time of order.

##### 3.1.2 Ventilation and space

- (a) Installation area should be well-ventilated.
- (b) The installation space should be large enough to facilitate heat dissipation and maintenance.

#### 3.2 Foundation

Motor manufacturer is not responsible for the foundation design. Motor weight, thrust load, twisting moments, seismic forces and other external applied loads must be considered in foundation design.

##### 3.2.1 Reactions of horizontal motor

For a horizontal motor with four hold down bolts, the reactions necessary for foundation design are as follows – kgs per bolt at centerline of hold down bolt holes :

- (a) Static weight = motor weight / bolt number
- (b) Rated motor torque ( $T_R$ ) , reactions = motor weight/bolt number  $\pm T_R/2L$
- (c) Maximum motor torque ( $T_{max}$ ) ,  
Reactions = motor weight/bolt number  $\pm T_{max}/2L$

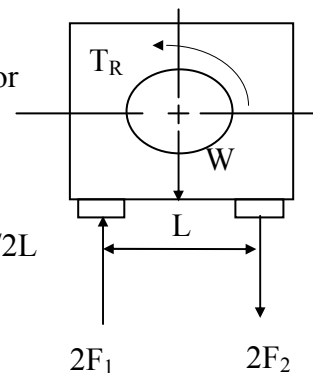

**Fig. 6**

##### 3.2.2 Soleplate & common bed

Use rigid and solid soleplate or common bed as foundation.

#### **ATTENTION !**

**For best motor performance, it is advisable to use a sole plate or common bed, particularly when using direct coupling.**

**If the sole plate or common bed does not have enough stiffness, the critical speed of motors or equipment will then be affected. This change may cause a large vibration (resonance) and decrease the life of the machines.**

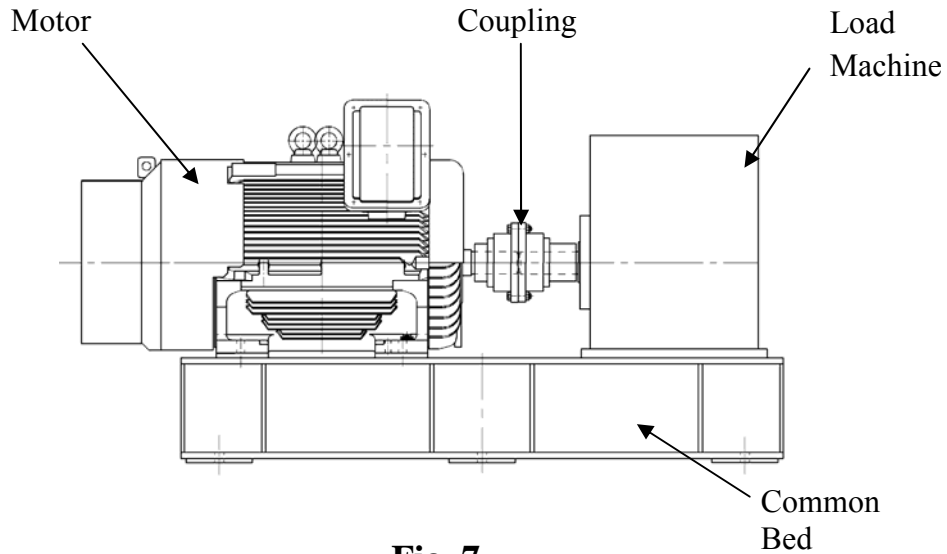

**Fig. 7**

### 3.2.3 Installation

- (a) Select an appropriate foundation surface for the soleplate or common bed which will be considered the ultimate level.
- (b) Align the position of the common bed with reference to that level at a minimum of four points. The accuracy should be within 0.04mm (1.5mil).
- (c) Sole plate or common bed should be embedded in concrete foundation as illustrated in Fig.8. Stiff pads should also be installed beneath the wedges which are welded together at various spots about 400-500mm (15-20inches) apart to enable the foundation to evenly carry the weight of the whole motor.
- (d) The base should be sturdy and rigid to keep it flat and level.
- (e) Make sure the mortar and concrete are completely dry and the precision of the level is acceptable, then set the motor on the mounting foundation.
- (f) After accurately install shaft couplings, weld the wedges to prevent soleplate or common bed moving.

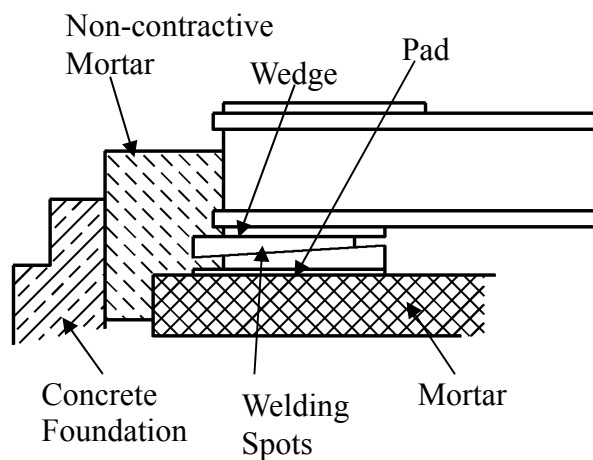

**Fig. 8**

### 3.2.4 The foundation of vertical induction motor (Also the foundation of pump)

- (a) Foundation of motor/pump must be rigid and secure to provide adequate support. There must be no vibration, twisting, misalignment etc. due to inadequate foundations.
- (b) A massive concrete foundation is preferred in order to minimize vibration. Rigidity and stability are enhanced by prop plate and foundation bolt. As shown in Fig.9 and Fig.10.

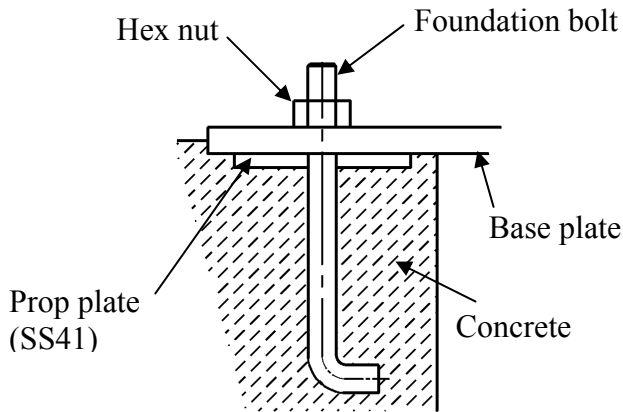

**Fig. 9**

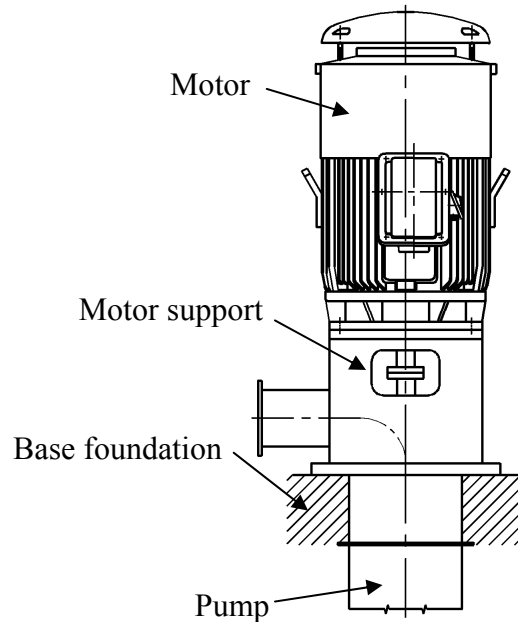

**Fig. 10**

### 3.2.5 Installation of vertical motor

- (a) All mounting surfaces must be planished and clean.
- (b) Foundation must be leveled at least at 4 points and guaranteed to be below 0.04mm flat and level.
- (c) Make sure the mortar and concrete are completely dry, and the precision of the level is acceptable, then set the motor on the mounting foundation.
- (d) Accurately install shaft couplings.

---

### 3.3 Installation of shaft coupling

#### 3.3.1 General

**ATTENTION !**

**Motors must always be accurately aligned, and this applies especially where they are directly coupled.**

**Incorrect alignment can lead to bearing failure, vibration and even shaft fracture. As soon as bearing failure or vibration is detected, the alignment should be checked.**

#### 3.3.2 Mounting procedure

Field application of a coupling to the motor shaft should follow the procedures recommended by the coupling manufacturer. The motor shaft extension must not be subjected to either extreme heat or cold during coupling installation.

#### 3.3.3 End-play

Although the sleeve bearings are equipped with thrust faces, these are intended only to provide momentary axial restraint of rotor movement either during start-up or when operating the motor disconnected from the driven equipment. They must not be operated under a constant thrust load unless they were originally designed for this condition.

Motors with either sleeve or anti-friction bearings are suitable for connection to the driven load through a flexible coupling. Coupling solidly to the load is not acceptable. With sleeve bearings, the flexible coupling should be of the limited end float type to prevent the possibility of any end thrust from the load being transmitted to the motor bearings, which could cause bearing damage.

The recommended limits of end float for couplings are as follows :

- (a) When the motor is in operation after installation, be sure that the end-play indicator is within the 6mm of the groove on the shaft or aligned to the shaft shoulder immediately outboard of the drive-end bearing to assure there is low friction between shaft and bearing.
  - (b) Unless otherwise specified, the designed end-play value X of the groove for TECO-Westinghouse motors in general is within 7mm (0.276") as illustrated in Fig. 11. In essence, the end-play indicator is adjusted to point at the center of the groove or the drive-end shaft shoulder; thus X equals to  $7 \pm 1$ mm (0.276"  $\pm$  0.039") or so, and the end-play value (Y) of the couplings should equal or be smaller than 2.4mm (0.094").
  - (c) If the desired value Y is greater than 3mm (0.118") caused for instance by a thrust load and/or load machine with large end-play, please inform us at time of order.
-

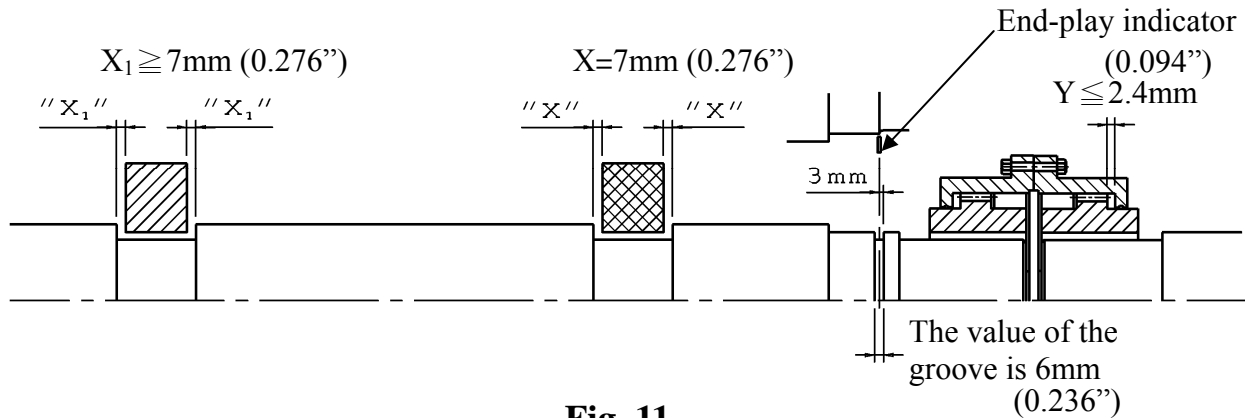

**Fig. 11**

### 3.3.4 Thermal growth

In aligning the motor (and rotor) axially with the driven equipment, consideration should be given not only to the end-play indicator position but also to axial shaft expansion and increase in shaft centerline height due to thermal effects. In general, the axial shaft growth for motors can be disregarded since neither bearing fixed nor any shaft growth due to temperature increase will produce an elongation away from the coupling.

Shaft height growth (change in shaft centerline elevation) for TEFC machines can be calculated as follows :

$$\Delta = (0.0005) \times (\text{motor foot to shaft centerline dimension})$$

For non-TEFC machines, divide this number by 2.

### 3.3.5 Alignment

It is desirable, in normal operation, that the motor operate on its magnetic center, so that no axial force is exerted on the coupling.

The motor shaft and the driven shaft should be aligned within the following tolerances in both angular and parallel alignment :

Unit : mm

TIR	Range of rotating speed	Solid coupling	Flexible coupling
C	2500rpm and above	0.03	0.03
	Below 2500rpm	0.04	0.05
A	2500rpm and above	0.03	0.03
	Below 2500rpm	0.03	0.04

**Angular misalignment** is the amount by which the centerlines of driver and driven shaft are skewed. It can be measured using a dial indicator set up as shown in Fig.12. The couplings are rotated together through 360 degrees so that the indicator does not measure run out of the coupling hub face. The shafts should be forced against either the in or out extreme of their end float while being rotated.

**Parallel misalignment** is the amount by which the centerlines of the driver and driven shafts are out of parallel. It can be measured using a dial indicator set up as shown in Fig.13. Again, the couplings are rotated together through 360 degrees so that the indicator does not measure runout of the coupling hub outside diameter.

**TIR** = Total indicator reading (by dial indicator)

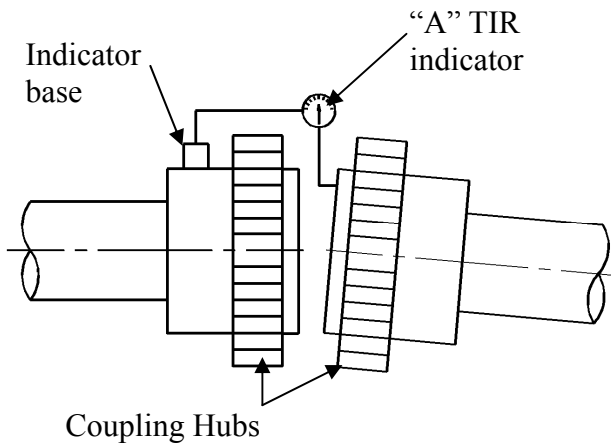

**Fig. 12**

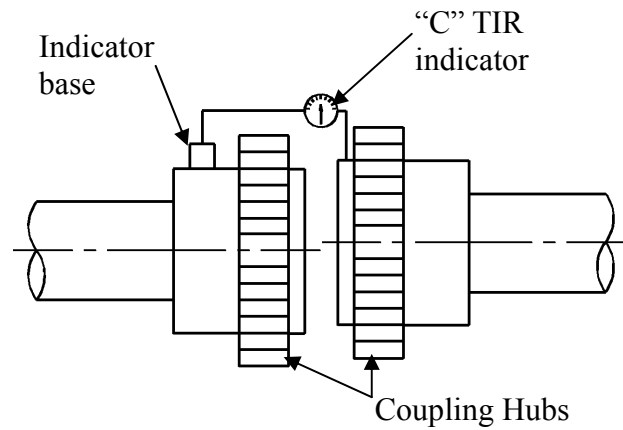

**Fig. 13**

**ATTENTION !**

Measurements should be made only after shimming and with hold-down bolts properly tightened.

### 3.3.6 Shims for horizontal motor

During alignment, the motor is adjusted vertically by shimming between the mounting surface and the motor feet. The shims (furnished only if part of the motor order) should be as large as the projected area of the motor foot pad and should either partially or completely encircle the hold-down bolts. Shimming must be done carefully to prevent any uneven support of the frame feet that could result in frame distortion due to hold-down bolt tension. When properly shimmed, it should be possible to insert 0.05mm thick feeler gauge between the top shim and the bottom of any frame foot.

### 3.3.7 Dowel for horizontal motor

After the motor has been properly aligned with the driven equipment and the hold-down bolts have been installed and tightened, for motors with fabricated frame, at least two dowel pins should be installed in two diagonally opposite motor feet.

For motors with fabricated frame, pilot holes are provided to facilitate final field drilling and reaming of the required dowel holes. Since the dowel pilot hole in the frame foot is set at a 45° angle from the vertical, it may first be necessary to spot face the motor mounting surface. This can be accomplished with a flat bottom drill utilizing the pilot hole as a guide.

### 3.3.8 Installation of shaft coupling (Vertical hollow shaft motor only)

Bolted coupling as Fig.14

- (a) Bearings are provided to absorb some upward shaft thrust when the coupling is fitted.
- (b) The coupling is fastened with bolts.
- (c) This coupling type is not auto-release type.

Note : Standard high thrust motors can absorb momentary upthrust load up to 30% of the standard downthrust load. If the upthrust is long duration (over 10 seconds) and/or exceeds 30% of the standard high thrust rating, special design arrangements are required and a standard motor is not suitable.

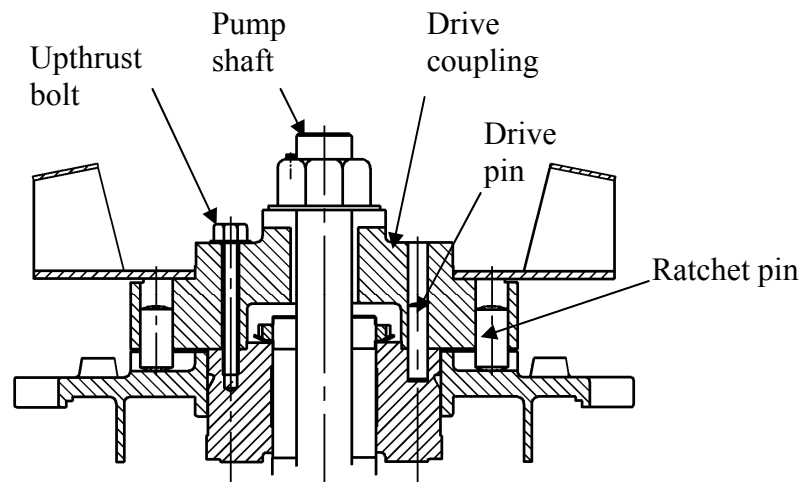

**Fig. 14**

### 3.3.9 Non-reverse ratchet/coupling, as Fig. 14 (If fitted)

The non-reverse coupling is also a bolted type and,

- (a) It prevents the pump and motor from rotating in the reverse direction.
- (b) It also prevents damage from over speeding and damage to pump shaft and bearings.
- (c) The ratchet pins are lifted by the ratchet teeth and are held clear by centrifugal force and friction as the motor comes up to speed.
- (d) When power is removed, speed decreases, and the pins fall. At the instant of reversal, a pin will catch in a ratchet tooth and prevent backward rotation.
- (e) When installing the non-reverse coupling, do not use lubricant. Lubrication will interfere with proper operation. The top half of the coupling should seat solidly on the lower half and the pins should touch the bottom of the pockets between the teeth in the plate.
- (f) As with the bolted coupling, the upthrust capabilities are 30% of the standard high thrust rating for downthrust.

#### **ATTENTION !**

**Do not apply non-reverse ratchets on applications in which the pump reversal time from shutdown (the instant the stop button is pressed) to zero speed is less than one second.**

### 3.3.10 Manual rotation of large vertical rotor with sleeve bearing during alignment (Vertical motor only)

- (a) If there is a thread in the non-drive end shaft center, the breakaway torque can be overcome by the use of torque wrench provided there is no ratchet. Remove the top cover, insert a bolt in the threaded shaft center and use a torque wrench to apply the rotating force. The breakaway torque is decided if a torque wrench is feasible.

$$\text{Torque [kg-mm]} = \text{Rotor Wt [kg]} * \text{Thrust Pad Center Radius [mm]} * 0.4$$

0.4 = coefficient of friction for dry lubrication

- (b) An alternate is to use a long bar bolted to the coupling to apply the torque.
- (c) If the rotor can be lifted either from above using a crane attached to the top of the rotor or from below using a jack, then the rotor weight is reduced and the torque needed to breakaway is much less. This does not always work, as sometimes the pads adhere to the thrust collar face due to cohesion.

There is no danger of Babbitt damage due to breakaway because it only takes a small revolution of the rotor to lubricate all shoe surfaces.

### 3.3.11 Removal of redundant shaft key

When the length of coupling hub is different from the length of shaft key, the motor may have a high vibration level due to this unbalance condition. The removal of redundant shaft key is necessary, shown as Fig.15.

#### Method (1) :

After installing the coupling, use a grinding wheel to remove the redundant key (hatch area).

#### Method (2) :

Before installing the coupling, calculate the different length between coupling hub and shaft key, then cut the half of this different value (hatch area) to achieve approximate-balance condition.

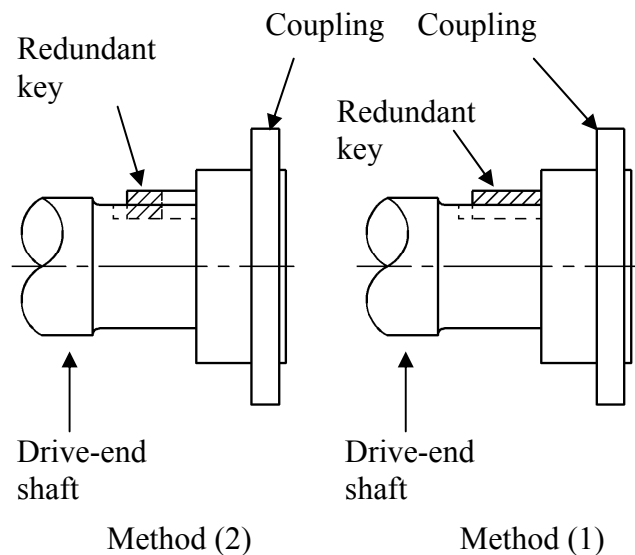

**Fig. 15**

### 3.4 Installation for belt drive

#### 3.4.1 General

In general, power transmission through direct flexible coupling is appropriate for large motors. Such motors are not suitable for belt, chain or gear connection unless specially designed for such service. However, for small and medium motors of which outputs within the ranges shown on table below, it is acceptable to use belt transmission as indicated. Beyond these ranges, do not apply belt sheaves unless specially designed.

#### 3.4.2 Diameter of sheaves

The diameter ratio between conveyance sheaves should not be greater than 5 to 1 for flat belts, and 8 to 1 for V-belt. It is also advisable to limit the belt velocity to under 35 m/sec to limit belt abrasion and vibration. The smaller the outer diameter of the V-belt sheave, the greater the shaft bending stress will be. If the bending stress is in excess of the shaft fatigue stress, the shaft may break. Therefore, please inform us when you have decided the size of the sheaves and the length of the belts upon ordering.

#### ATTENTION !

Place the sheave and belt as close as possible to the motor body ( it is advisable to make x as shown in Fig.16 equal to 0 ) to reduce the bending moment and improve shaft life.

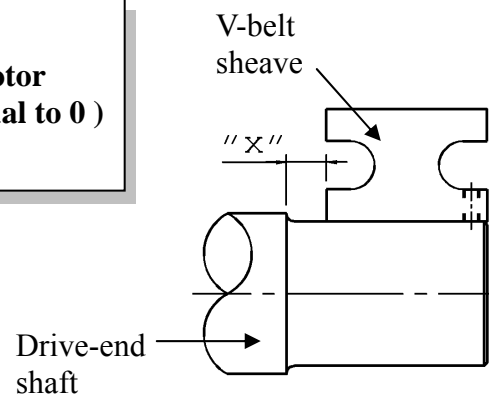

Fig. 16

#### 3.4.3 Table of belt-sheave application for general electric motors

Output (kW)			V-Belt Sheave							
			Conventional V-Belt				Narrow V-Belt			
4P	6P	8P	V-Belt Type	Number of Belts	Min. PCD (mm)	Max. Width (mm)	V-Belt Type	Number of Belts	Min. PCD (mm)	Max. Width (mm)
45	--	--	C	6	265	162	5V	4	224	78
--	45	--	C	7	280	187	5V	5	224	95
--	--	45	C	7	315	187	5V	6	250	113
55	--	--	C	7	265	187	5V	5	224	95
--	55	--	C	8	300	213	5V	6	250	113
--	--	55	D	5	355	196	5V	6	280	113
75	--	--	C	8	315	213	5V	6	250	113
--	75	--	D	6	355	233	5V	6	315	113
--	--	75	D	6	400	233	5V	6	355	113
--	90	--	D	6	400	233	5V	6	355	113
--	--	90	D	6	425	233	8V	4	355	124
--	110	--	D	7	400	270	8V	4	355	124
--	132	110	D	7	450	270	8V	4	400	124
--	160	132	D	9	450	344	8V	4	450	124

## 3.5 Conveyance with chain or gear

### 3.5.1 Loading capacity

Make sure the loading capacity of shaft and bearings is appropriate for the size and installation position (overhung) of chain and gear. If necessary, please contact us to ensure the shaft and bearings will meet your requirements.

### 3.5.2

Pay close attention to ensure the parallelism of shafts.

### 3.5.3

The teeth of couplings should be correctly and precisely matched; the force conveyance centers should lie on the same line.

### 3.5.4

There should be no skip, jumping, vibration or unusual noises.

#### **ATTENTION !**

**Do not hammer the conveyance devices such as couplings, belt sheaves, chain wheels, gears etc. onto the shaft. Those shaft fitments should be fitted and removed only by means of suitable devices. Heat shrinking may be a better alternative to avoid damaging bearings and other components.**



**The exposed rotating parts should be covered to prevent accidents.**

---

---

## 3.6 Electrical connections

All interconnecting wiring for controls and grounding should be in strict accordance with local requirements such as the USA National Electrical Code and UK IEE wiring regulations.

Wiring of motor and control, overload protection and grounding should follow the instructions of connection diagrams where provided.

### 3.6.1 Power

The rated conditions of operation for the motor are as shown on the nameplate. Within the limits, given below, of voltage and frequency variation from the nameplate values, the motor will continue to operate but with performance characteristics that may differ from those at the rated conditions :

+/- 10% of rated voltage

+/- 5% of rated frequency

+/- 10% combined voltage and frequency variation so long as frequency variation is no more than +/- 5% of rated

#### **ATTENTION !**

**Operating the motor at voltages and frequencies outside of the above limits can result in both unsatisfactory motor performance and damage to or failure of the motor.**

### 3.6.2 Main lead box

The main lead box furnished with the motor has been sized to provide adequate space for the make-up of the connections between the motor lead cables and the incoming power cables.



**The bolted joints between the motor lead and the power cables must be made and insulated in accordance with the best industry practices.**

### 3.6.3 Grounding

Both fabricated steel motors and fan cooled cast frame motors are provided with grounding pads or bolts.



**The motor must be grounded by a proper connection to the electrical grounding system.**

### 3.6.4 Rotation direction

The rotation direction of the motor will be as shown by either a nameplate on the motor or the outline drawing. The required phase rotation of the incoming power for this motor rotation may also be stated. If either is unknown, the correct sequence can be determined in the following manner :

While the motor is uncoupled from the load, start the motor and observe the direction of rotation. Allow the motor to achieve full speed before disconnecting it from the power source. Refer to the operation section of these instructions for information concerning initial start-up. If resulting rotation is incorrect, it can be reversed by interchanging any two (2) incoming cables.

---

### 3.6.5 Auxiliary devices

Auxiliary devices such as resistance temperature detectors, thermocouples, thermoguards, etc., will generally terminate on terminal blocks located in the auxiliary terminal box on the motor. Other devices may terminate in their own enclosures elsewhere on the motor. Such information can be obtained by referring to the outline drawing. Information regarding terminal designation and the connection of auxiliary devices can be obtained from auxiliary drawings or attached nameplates.

If the motor is provided with internal space heaters, the incoming voltage supplied to them must be exactly as shown by either a nameplate on the motor or the outline drawing for proper heater operation.

**ATTENTION !**

**Caution must be exercised anytime contact is made with the incoming space heater circuit as space heater voltage is often automatically applied when the motor is shutdown.**

---

## 4. OPERATION

### 4.1 Examination before start

#### 4.1.1 Wiring check

When motors are installed in good manner, ensure the wiring is according to the diagram. Also, the following points should be noted :

- (a) Make sure all wiring is correct.
- (b) Ensure the sizes of cable wires are appropriate and all connections are well made for the currents they will carry.
- (c) Ensure all connections are properly insulated for the voltage and temperature they will experience.
- (d) Ensure the capacity of fuse, switches, magnetic switches and thermo relays etc. are appropriate and the contactors are in good condition.
- (e) Make sure that frame and terminal box are grounded.
- (f) Make sure that the starting method is correct.
- (g) Make sure switches and starters are set at their right positions.
- (h) Motor heaters must be switched off when the motor is running.

#### 4.1.2 Measurement of insulation resistance



**During and immediately after measuring, the terminals must not be touched as they may carry dangerous residual voltages. Furthermore, if power cables are connected, make sure that the power supplies are clearly disconnected and there are no moving parts.**

- (a) For rated voltage below 1000V, measured with a 500VDC megger.  
For rated voltage above 1000V, measured with a 1000VDC megger.
- (b) In accordance with IEEE 43-2000, there are three recommendation minimum insulation resistance values. These values corrected to 40°C are :
  - (1) kV+1 in Megohms for most windings made before 1970, all field windings and windings not otherwise described.
  - (2) 100 Megohms for most DC armatures and AC windings built after about 1970 with form wound coils.
  - (3) 5 Megohms for machines with random wound stator coils and for form wound coils rated below 1kV.

### **ATTENTION !**

**After measurement the winding must be grounded or shunted to discharge residual voltages.**

- (c) On a new winding, where the contaminant causing low insulation resistance is generally moisture, drying the winding through the proper application of heat will normally increase the insulation resistance to an acceptable level. The following are several accepted methods for applying heat to a winding :

- (1) If the motor is equipped with space heaters, they can be energized to heat the winding.
- (2) Direct current (as from a welding equipment) can be passed through the winding. The total current should not exceed approximately 20% of rated full load current. If the motor has only three leads, two must be connected together to form one circuit through the winding. In this case, one phase will carry the full applied current and each of the others, one-half each. If the motor has six leads (3 mains and 3 neutrals), the three phases should be connected into one series circuit.



**Ensure there is adequate guarding so live parts cannot be touched.**

- (3) Heated air can be either blown directly into the motor or into a temporary enclosure surrounding the motor. The source of heated air should preferably be electrical as opposed to fueled (such as kerosene) where a malfunction of the fuel burner could result in carbon entering the motor.

### **ATTENTION !**

**Caution must be exercised, when heating the motor with any source of heat other than self contained space heaters, to raise the winding temperature at a gradual rate to allow any entrapped moisture to vaporize and escape without rupturing the insulation. The entire heating cycle should extend over 15-20 hours.**

Insulation resistance measurements can be made while the winding is being heated. However, they must be corrected to 40°C for evaluation since the actual insulation resistance will decrease with increasing temperature. As an approximation for a new winding, the insulation resistance will be approximately halved for each 10°C increase in insulation temperature above the dew point temperature.

- (d) Should the resistance fail to attain the specified value even after drying, careful examination should be undertaken to eliminate all other possible causes, if any.

#### **4.1.3 Power source**

- (a) Ensure the capacity of the power source is sufficient.
  - (b) Ensure the supply voltage and frequency ratings are identical to those on the nameplate.
  - (c) Voltage variation should be confined to  $\pm 10\%$  of the rated value and the phase to phase voltages should be balanced.
-

#### 4.1.4 Bearing lubrication

- (a) For sleeve bearing motors, the oil reservoir must be filled with oil to the correct level. On self-lubricated bearings, the standstill oil level will be at the center of the oil gauge. The proper oil is a rust and oxidation inhibiting, turbine grade oil. Refer to the lubrication nameplate for the recommended viscosity.
- (b) Motors which are supplied with provision for flood lubrication have an inlet orifice to meter the oil flow to the bearing. Refer to the outline drawing for these values. If the supply pressure does not match that stated on the outline, the orifice size must be adjusted to produce the specified flow rate. In line with operation conditions (degree of contamination of the oil) filters must be cleaned according to the instructions of the manufacturer. The recommendation mesh size of the filters is 15~20  $\mu$  m.

The drain adapter (also provided) has a weir plate fixed to the inside of the pipe to permit the establishment of the proper oil level. This weir plate must be located at the bottom of the pipe and must be parallel to the plane of the motor feet. To ensure optimum flow, the drain line should be vented to the atmosphere.

Oil inlet temperature :

Normal	20°C (70°F) ~ 49°C (120°F)
Alarm	60°C (140°F)
Trip	65°C (150°F)

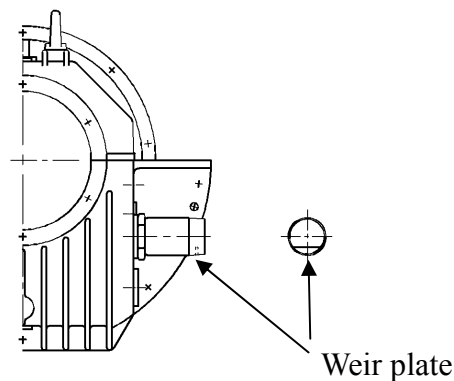

**Fig. 17**

- (c) If the motor is in storage for over three (3) months, refilling of some new oil should be undertaken before operation to prevent bearing damage due to dry friction. The oil level should be kept at the center of the oil gauge. If necessary, drain some oil after refilling.
- (d) Grease lubricant type
- (1) The bearings have been well greased at factory before delivery. However, regreasing is required if a significant period has elapsed between manufacture and use or in storage. Fill new grease until it overflows and the old grease is entirely replaced.
  - (2) Unless otherwise specified and shown on nameplate, ExxonMobil Polyrex EM is the standard applied to TECO-Westinghouse motors.
  - (3) If roller bearing is used, add a small amount of grease if abnormal sound occurs in the bearings. If this sound, disappears temporarily after regreasing, it is a normal condition and can operate as it is, as long as the temperature rise of the bearing is normal.

#### 4.1.5 Oil-mist lubrication motors

Unless otherwise specified, Inpro seals are used as TECO-Westinghouse standard.

(a) Before operation :

Please check the rotor & stator parts of the Inpro seal, and make sure that they don't contact each other. A 0.03mm feeler gauge is suggested to inspect the gap between rotor and stator as shown in Fig.15. If they are touching on one side, it means that this seal is in the wrong position. You can use a wooden or rubber hammer to adjust this seal gently. If this can't be done, this seal may be damaged and have to be checked. Please contact with our service department.

(b) Lubricant :

Please use ISO VG68 or equal viscosity oil..

(c) About the oil mist lubrication generation system :

The users have to prepare an oil mist lubrication system and apply suitable inlet oil quantity and pressure. Please follow the instruction for the oil mist lubrication system that you used. Avoid high oil pressure to prevent oil from going into the inside of the motor damaging the insulation or causing oil leakage.

(d) Operation :

Before first operation or after a long time without running, please turn on the oil mist lubrication system for at least 5 hours to lubricate the bearings. If you use the central control system, the mist system shall operate continuously for a minimum of 48 hours. After making sure the pressure is stable and flow out oil is in good condition, you can operate this motor.

(e) Appendix :

Fitting or reclassifier of oil-mist lubrication system :

Reclassifiers or fittings are devices which convert small particle-size dry mist to larger particle sizes which can lubricate bearings. Please use correct fittings or reclassifiers.

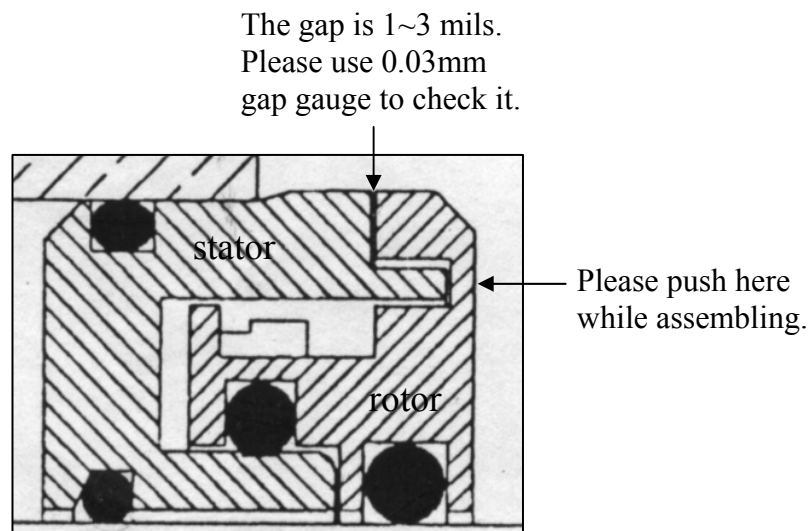

**Fig. 18**

#### 4.1.6 Cooling water for the motors with water jacket (TEWC)

Make sure the quality, volume and inlet temperature of cooling water for the motors are normal before the machine is in operation.

Water : General tower water or industrial water, the suspended solid shall be below 20  $\mu$  m/l

Volume : Please see outline drawing

Inlet temperature : Normal below 30°C (86°F) ; above 5°C (41°F)

Alarm 35°C (95°F)

Trip 40°C (104°F)

Special temperature settings will be noted in outline drawings.

#### 4.1.7 For motors equipped with independent force-ventilating blower unit

- (a) Ensure the voltage and frequency of the power source are identical to the ratings shown on blower motor name plate.
- (b) Ensure the wiring to blower motor is according to the connection diagram.
- (c) Test run the blower motor to ensure the phase currents are within the tolerance limits.
- (d) Ensure the cooling air flow direction is correct. Refer to motor outline for cooling air flow direction.
- (e) Blower motor should be started prior to operating the main motor.
- (f) Do not switch off the blower motor immediately after the main motor is shut off. It must be left running for 15 minutes after the main motor is shut down.
- (g) For small blower motor, double shield and pre-lubricated ball bearings are used and re-lubrication is not necessary.

#### 4.1.8 Remove all locks

##### **ATTENTION !**

**Make sure all locks which fasten the movable parts of the motor during transportation are dismantled and the shaft can rotate freely.**

#### 4.1.9 Clean before starting

##### **ATTENTION !**

**Ensure there are no foreign matters or tools inside the motor before starting.**

#### 4.1.10 Transmission system check

Make sure the transmission system, including belts, screws, bolts, nuts and set pins are in good condition.



**The keys fitted to the shaft extensions are held by plastic tape only to prevent them from falling out during transportation or handling. The shaft key shall be removed to prevent it from flying out, when the motor is operated prior to the couplings etc. being fitted to the shaft extension.**

#### 4.1.11 Test run

Make sure the items above are examined. Test the motor running with or without load. Record and check according to the statement of 5.11 "Records of operation and maintenance" at 15 minute intervals during the first three hours of operation. Then regular examinations should take place at longer intervals. If everything goes well, the motor can be classified as "in good order".

**ATTENTION !**

**To avoid the abnormal bearing temperature and vibration level increase, we suggest do not run a vertical high thrust motor continuously without load.**

---

---

## 4.2 Starting operation

### 4.2.1 Starting load

Initially run the motor unloaded prior to coupling to other machines. Unless otherwise specified, a motor usually starts with light load which is then gradually increased proportional to the square of speed and at last reach 100% load at full load speed.

### 4.2.2 Starting

Too frequent starts can harm the motors. The following restrictions should be observed :

- (a) Motor can be restarted should the initial start fail. Two starts are generally permissible when the motor is cold.
- (b) Motor can be started only once when it is at normal running temperature.
- (c) Should additional starts be necessary beyond the conditions stated above, the following restrictions should be noted :
  - (1) Let the motor cool down for 60 minutes before restarting, fully loaded.
  - (2) Let the motor cool down for 30 minutes before restarting, unloaded.
  - (3) Two inching starts can be regarded as one normal start.

#### **ATTENTION !**

**If the motor rotor fails to start turning within one or two seconds, shut off the power supply immediately.**

**Investigate thoroughly and take corrective action before attempting a restart.**

Possible reasons for not starting are :

- (1) Voltage drop at the motor terminals is more than allowed (look to confirmed data sheet).
- (2) The counter torque is too large to accelerate the rotor.
- (3) The driven machine is stuck, jammed or blocked.
- (4) The electrical connections have not been made correct to drawings and standards.
- (5) One phase is missing or single phase power has been applied.
- (6) Any combination of the above.

### 4.2.3 Rotating direction

- (a) Most TECO-Westinghouse motors can be operated in bi-directional rotation. However, when some special types, such as high speed 2P, certain large capacity motors, those with a non-reverse ratchet etc. should rotate in one direction, please ensure the rotation is in conformity with the directional arrow-mark shown on the attached nameplate.
  - (b) To reverse a bi-directional motor, cut the power and wait until the motor stops. Then interchange any two of the three phases.
-

#### 4.2.4 Power source, voltage, current

- (a) Ensure the voltage and frequency of the power source are identical to the ratings shown on the nameplate.
- (b) Voltage variation should be confined to  $\pm 10\%$  of the rating and the three phase voltages should be in full balance.
- (c) Ensure the motor phase currents in no-load condition could be variably, within  $\pm 5\%$  of the average values.

#### 4.2.5 Power source, frequency

The variation of the frequency should be confined to  $\pm 5\%$  of the rating. The aggregate variation of voltage and frequency should be confined to  $\pm 10\%$  of the absolute value of the ratings.

#### 4.2.6 Starting time and unusual noises

**ATTENTION !**

**Starting time is longer for the motors with large inertia. However, if starting time is longer than usual or if there is difficulty in starting, or there is abnormal noise, do not run the motor and refer to TECO-Westinghouse.**

#### 4.2.7 Sleeve bearing oil rings (sleeve bearing types only)

As the oil ring is used to carry lubricant to sleeve bearings, frequently check to ensure the oil ring is in motion.

---

#### 4.2.8 Bearing temperature rise

Following the initial start-up, the bearing temperatures should be closely monitored. The rise rate of bearing temperature is more indicative of impending trouble than is the actual temperature.

##### **ATTENTION !**

**If the rise rate of the temperature is excessive, the motor exhibits excessive vibration or unusual noise, shut down the motor immediately. Before start up the motor again, a thorough investigation has been made to figure out the cause.**

If the bearing temperature rise and motor operation appear to be normal, operation should continue until the bearing temperature is stabilized.

Recommended limits on bearing temperature are as follows :

	Alarm Temperature setting	Trip temperature setting
Sleeve Bearings By permanently installed detector	90°C (194°F)	95°C (203°F)
Anti-friction Bearings By permanently installed detector	95°C (203°F)	100°C (212°F)

##### **ATTENTION ! (For sleeve bearing)**

- (1) Flood lubrication sleeve bearings without external lubrication supply, the bearing temperature must not be allowed to exceed 85°C in total.
- (2) Self-lube bearing, the rate of temperature rise should be from 11K to 14K for the first ten (10) minutes after starting up and approximately 22K at thirty (30) minutes. The rate of bearing temperature rise is a function of the natural ventilation and operating conditions.
- (3) When the rate of bearing temperature rise is less than  $\pm 1\text{K}$  per (30) minutes, the bearing temperature is considered to steady conditions.
- (4) If the total bearing temperature exceeds 95°C, the motor should be shut down immediately and a thorough investigation has been made to figure out the cause.

##### **ATTENTION !**

**If the rise rate of the temperature is excessive, the motor exhibits excessive vibration or unusual noise, shut down the motor immediately. Before start up the motor again, a thorough investigation has been made to figure out the cause.**

4.2.9 Noise and Vibration

**ATTENTION !**

**Any abnormal noise or vibration should be immediately investigated and corrected. Increased vibration can be indicative of a change in balance due to mechanical failure of a rotor part, a stator winding problem or a change in motor alignment.**

(a) NEMA MG1, vibration limits at no load

Unfiltered Vibration Limits		
Speed, rpm	Rotational Frequency, Hz	Velocity, in./s peak (mm/s)
3600	60	0.15 (3.8)
1800	30	0.15 (3.8)
1200	20	0.15 (3.8)
900	15	0.12 (3.0)
720	12	0.09 (2.3)
600	10	0.08 (2.0)

(b) ISO 10816, overall vibration severity chart for customer’s reference

Machine	Machine		Class I Small machine	Class II Medium machine	Class III Large rigid foundation	Class IV Large soft foundation
	in/s	mm/s				
Vibration Velocity (r.m.s.)	0.01	0.28	Good	Satisfactory	Unacceptable	
	0.02	0.45				
	0.03	0.71				
	0.04	1.12				
	0.07	1.80				
	0.11	2.80				
	0.18	4.50				
	0.28	7.10				
	0.44	11.2				
	0.70	18.0				
0.71	28.0	Unacceptable				
1.10	45.0					

#### 4.2.10 Recommended winding temperature settings

An electric motor normally has built in “over temperature protection devices” such as thermistors and RTD’s. They are set to trip at levels dependent upon the Class of Insulation of the motor windings. Motors designated Class F insulation have an allowable total temperature of 155°C in total. For those motors, the recommended alarm and trip settings are as below:

Alarm	Trip
140°C (284°F)	155°C (311°F)

#### 4.2.11 Additional points to note

- (a) The motor characteristic data includes values for the acceleration and safe stall times, when specified by the customer. If the motor fails to reach full speed, shut off the power immediately. Investigate thoroughly and take corrective action before attempting to restart.
- (b) Each start of an induction motor subjects the motor to full inrush current with resulting heating of the stator and rotor windings. Each acceleration and repeated start can produce more heat than that produced and dissipated by the motor under full load.  
The starting duty for which the motor is designed is shown by a nameplate mounted on the motor and must not be exceeded, if long motor life is expected. Abnormally terminal voltage drop and/or excessive load torque during motor start-up can cause extended acceleration time during which rotor speed is reduced and ventilation is minimized. This can cause rotor destroying or can lead to extreme shorten of rotor life.
- (c) The temperature rating of the motor is shown on the main nameplate as a temperature rise above an ambient temperature. If there is a service factor, it is also shown.  
If the motor does not have stator winding temperature detectors and abnormal winding temperatures (as might be indicated by high discharge air temperature, odor, etc.) are suspected, the motor should be shut down immediately and an investigation made before further operation is attempted.

## 5. MAINTENANCE

### 5.1 Major points in regular inspection and maintenance



**Maintenance and repairs must only be carried out by properly trained personnel.**



**Some testing, such as insulation resistance, usually requires the motor to be stopped and isolated from power supply(ies).**

Routine inspection and maintenance are usually performed visually, audibly, by odor, and by means of simple meters.



**High temperature may arise under operating conditions on the motor surfaces, so touching should be prevented or avoided.**

**Keep away from moving and live parts.**

**Unless deemed necessary, do not remove guards while assessing the motor.**

Timely replacement of worn parts can assure longevity and prevent breakdown.

Routine and regular inspection and maintenance are important in preventing breakdown and lengthening service life.

Owing to the varied time and circumstances motors are used, it is difficult to set the items and periods for regular inspection and maintenance. However, as a guide it is recommended to be performed periodically according to factory maintenance program. Generally, the inspection scope is determined by the following factors :

- (a) Ambient temperature and ambient conditions (dust, humidity, other contamination).
  - (b) Starting and stop frequency.
  - (c) Troublesome parts usually affect motor dysfunctions.
  - (d) Easily abraded parts (slipring, brushes, earthing brushes).
  - (e) The important position of motor in the operational system should be duly recognized.  
Therefore, its life time should be intact and fully protected, especially when it is operating in severe conditions.
-

---

## 5.2 Motor windings

- (a) Measurement of insulation resistance and standards to determine quality of insulation resistance, please refer to measures stated in 4.1.2 "Measurement of insulation resistance".
- (b) Inspection of coil-ends :
  - (1) Grease and dust accumulated on coils may cause insulation deterioration and poor cooling effect.
  - (2) Moisture must not accumulate. Keep coils warm when motor is not in use (use space heater, if it's installed).
  - (3) Discoloring. This is mainly caused by overheating.
- (c) Ensure no untoward change of wedges from original position occurs.
- (d) Ensure the binding at the coil end is in its normal position.

## 5.3 Clean the interior of the motor

- (a) After a motor has been in operation for some time, accumulation of dust, carbon powder and grease etc., on the inside is unavoidable, and may cause damage. Regular cleaning and examination is necessary to assure top performance.
- (b) Points to note during cleaning :
  - (1) If using compressed air or a blower :
    - a) Compressed air should be free of moisture. Be sure, that the dust and other materials can come out of motor housing, iron core and windings.
    - b) Maintain air pressure below  $4 \text{ kg/cm}^2$ , since high pressure can cause damage to coils.
  - (2) Vacuum

Vacuum cleaning can be used before and after other methods of cleaning, to remove loose dirt and debris. It is a very effective way to remove loose surface contamination from the winding without scattering. Vacuum cleaning tools should be non-metallic to avoid any damage to the winding insulation.
  - (3) Wiping

Surface contamination on the winding can be removed by wiping using a soft, lint-free wiping material. If the contamination is oily, the wiping material can be moistened (not dripping wet) with a safety type petroleum solvent.

In hazardous locations, a solvent such as inhibited methyl chloroform may be used, but must be used sparingly and immediately removed. While this solvent is non-flammable under ordinary conditions, it is toxic and proper health and safety precautions should be followed while using it.

### **ATTENTION !**

**Solvents of any type should never be used on windings provided with abrasion protection. Abrasion protection is a gray, rubber-like coating applied to the winding end-turns.**

---



Adequate ventilation must always be provided in any area where solvents are being used to avoid the danger of fire, explosion or health hazards. In confined areas (such as pits) each operator should be provided with an air line respirator, a hose mask or a self-contained breathing apparatus. Operators should wear goggles, aprons and suitable gloves. Solvents and their vapors should never be exposed to open flames or sparks and should always be stored in approved safety containers.

- (4) Keep core ducts completely clean. The difference in temperature rise could be around 10°C before and after cleaning.

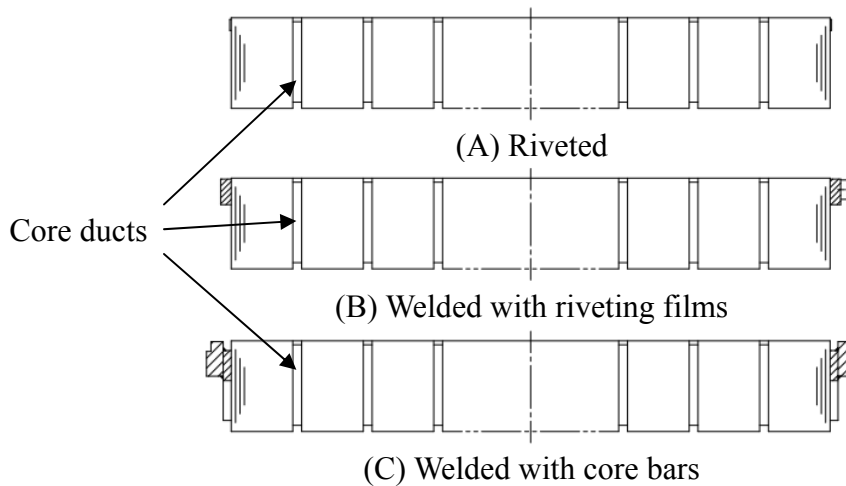

**Fig. 19**

#### 5.4 Clean the exterior of the motor

- (a) On open ventilated motors, screens and louvers over the inlet air openings should not be allowed to accumulate any build-up of dirt, lint, etc. that could restrict free air movement.

#### **ATTENTION !**

**Screens and louvers should never be cleaned or disturbed while the motor is in operation because any dislodged dirt or debris can be drawn directly into the motor.**

- (b) If the motor is equipped with air filters, they should be replaced (disposable type) or cleaned and reconditioned (permanent type) at a frequency that is dictated by conditions. It is better to replace or recondition filters too often than not often enough. The Permanent type air filters can be cleaned with fresh water, make sure to let them dry before reinstalling.

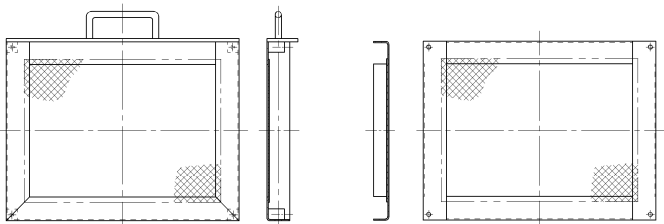

Disposable type filter fitted into two filter supports.

**Fig. 20**

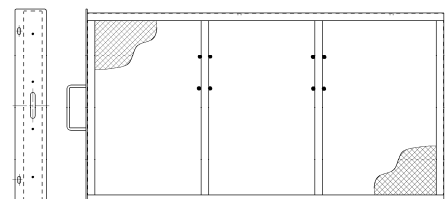

Permanent type filter.

**Fig. 21**

- 
- (c) Totally enclosed air-to-air cooled and totally enclosed fan cooled motors require special cleaning considerations. The external fan must be cleaned thoroughly since any dirt build-up not removed can lead to unbalance and vibration. All of the tubes of the air-to-air heat exchanger should be cleaned using a suitable tube brush having synthetic fiber bristles (not wire of any type).
- (d) It is important to keep the external surfaces of any motor clean and free from buildup of dirt and debris as this can function as an insulating blanket causing the motor to overheat drastically and could reducing the life of the motor. Methods of cleaning external surfaces are: Scraping, brushing, dry ice blasting etc.
-

## 5.5 Maintenance of anti-friction bearing

### 5.5.1 Frequency of relubrication

The life of grease varies greatly as a result of types of model, revolution speed, temperature, operational conditions etc. It is, therefore, impossible to be precise about replenishment intervals. However, for normal direct coupling transmission, the periods shown in Table 1 may be used as a guide.

#### Remarks :

- (a) The periods shown in Table 1 should be halved where bearings are used for belt drive and/or in dirty, high ambient temperature or high humidity environments.
- (b) Please refer to the lubrication nameplate, if attached to the motor.
- (c) For bearing numbers outside the range of Table 1, please contact TECO-Westinghouse.
- (d) If the periods referred to Table 1 for drive-end bearing and opposite drive-end bearing are different, for the convenience of maintenance operation, one could take the shorter one for re-greasing schedule.

### 5.5.2 Kinds of grease

ExxonMobil Polyrex EM grease is standard for TECO-Westinghouse motors except some special models for which special grease will be shown on the lubrication nameplate. Please use identical grease or its equivalents when maintaining.

#### **ATTENTION !**

**Do not mix different kinds of grease.**

**Mixing grease with different types of thickeners may destroy its composition and physical properties. Even if the thickeners are of the same type, possible differences in the additive may cause detrimental effects.**

---

Table 1

Bearing number		600 RPM	720 RPM	750 RPM	900 RPM	1000 RPM	1200 RPM	1500 RPM	1800 RPM	3000 RPM	3600 RPM
62XX 63XX 72XX 73XX	6210										
	12									2000Hrs	
	13										
	14									1000Hrs	
	15										
	16									720 Hrs	
	17									2000Hrs	
	18	3000Hrs								500 Hrs	
	20										
	22										
	24									1500Hrs	
	26										
	28									2000Hrs	
	30									1000Hrs	
	32									500 Hrs	
	34									1500Hrs	
36											
38	2000Hrs								1000Hrs		

Bearing number		600 RPM	720 RPM	750 RPM	900 RPM	1000 RPM	1200 RPM	1500 RPM	1800 RPM		
NU2XX NU3XX	NU214										
	15									2000Hrs	
	16										
	17										
	18	3000Hrs								1500Hrs	
	20										
	22									1000Hrs	
	24										
	26									2000Hrs	
	28									500 Hrs	
	30										
	32										
	34									2000Hrs	
	36									1000Hrs	
	38	2000Hrs									
	40										
44									1000Hrs		
48	1000Hrs								500 Hrs		

Bearing number		600 RPM	720 RPM	750 RPM	900 RPM	1000 RPM	1200 RPM	1500 RPM	1800 RPM		
222XX 223XX	22220									300Hrs	
	22										
	24	1000Hrs								500 Hrs	
	26										
	28										
	30									300 Hrs	
	32									500 Hrs	
	34										
	36										
	38	500 Hrs									
	40									300 Hrs	
44											
48	300 Hrs										

### 5.5.3 Grease quantity

The amount of grease per replenishment depends on the type, size and construction of the bearings. The minimum amount for replenishment of each bearing is shown in Table 2.

Table 2

Bearing No.		Amount of replenishment	Bearing No.		Amount of replenishment
62XX	6210	30g	63XX	6310	40g
72XX	6212	40	73XX	6312	60
NU2XX	6213	50	NU3XX	6313	80
222XX	6214	50	223XX	6314	80
	6215	60		6315	100
	6216	60		6316	100
	6217	80		6317	120
	6218	80		6318	120
	6220	100		6320	160
	6222	120		6322	220
	6224	120		6324	270
	6226	140		6326	300
	6228	160		6328	400
	6230	180		6330	450
	6232	200		6332	500
	6234	250		6334	600
	6236	300		6336	700
	6238	350		6338	800
	6240	400		6340	900
	6244	450		6344	900
	6248	500		6348	900

Fill desirable however to regrease until it replaces and the old grease is entirely replaced. The temperature of the bearing will initially increase because of the excess grease. After a few hours, the excess grease will be expelled through the exit tube and the bearing temperature will return to normal.

### 5.5.4 Re-greasing



**If relubrication is to be performed when the motor is running, stay clear of rotating parts.**

It is advisable to re-grease while the motor is running to allow the new grease to be evenly distributed inside the bearing.

Before re-greasing, the inlet fitting should be thoroughly cleaned to prevent any accumulated dirt from being carried into the bearing with the new grease. The outlet or grease drain should be opened to allow the proper venting of old grease.

Use a grease gun to pump grease through grease nipple into bearings slowly. After re-greasing, operate the motor for 10-30 minutes to allow any excess grease to vent out.

### 5.5.5 Oil relubrication (For oil lubrication types only)

Maintain proper lubrication by checking the oil level periodically and adding oil when necessary. Because of the initial clearing action of the bearing and the expansion of the oil as it comes up to operating temperature, the oil level will be higher after the motor has been in operation for a while than it is with the motor at standstill.

Overfilling should be avoided not only because of the possibility that expansion may force the oil over the oil sleeve and on to the rotor, but also because too high an operating oil level prevents the bearing from clearing itself of excess oil. The resultant churning can cause extra loss, high temperatures, and oxidized oil. If, the oil level goes above the maximum shown on the sight gauge during operation, drain enough oil to bring the level back within the recommended operating range.

Do not permit the operating level to fall below the minimum shown on the sight gauge.

#### **ATTENTION !**

**Should it ever become necessary to add excessive amount of make-up oil, investigate immediately for oil leaks.**

Change the oil at regular intervals. The time between oil changes depends upon the severity of operating conditions and, hence, must be determined by the motor user. Two or three changes a year is typical, but special conditions, such as high ambient temperature, may require more frequent changes. Avoid operating the motor with oxidized oil.

Use only good quality, oxidation-corrosion-inhibiting turbine oils produced by reputable oil companies. The viscosity of the oil to be used depends upon the type and size of the bearing, its load and speed, the ambient temperature, and the amount and temperature of the cooling water (if used). The lubrication nameplate or instructions with each motor specifies the viscosity range of oil suitable for average conditions. The usual oil viscosity recommendations are summarized in Table 3. Operation in ambient temperatures that are near or below freezing may require preheating the oil or the use of special oil. Whenever the motor is disassembled for general cleaning and reconditioning, the bearing housing may be washed out with a suitable cleaning solvent. Be sure that the oil metering hole is clear, and then dry the housing thoroughly before reassembly, and ensure all traces of cleaning solvent have been removed.

Table 3 oil viscosity for vertical motors\*\*

Bearing Type	Oil viscosity	Range of pole
Angular contact ball (72XX , 73XX)	ISO VG32 (150 SSU/100°F)	2 pole
	ISO VG68 (300 SSU/100°F)	4 pole and above
Spherical roller (293XX , 294XX)	ISO VG68 (300 SSU/100°F)	4 pole
	ISO VG150 (700 SSU/100°F)	6 pole and above

\*\*Note: Where a lubrication nameplate is attached to the motor, use the lubrication oil it stipulates.

### 5.5.6 Cleaning and installation of bearings

- (a) Apply the proper amount of grease to disassembled parts of the bearing after they have been thoroughly cleaned with high quality cleaning oil. Then protect them from contamination before and during assembly.
- (b) Bearing installation

**ATTENTION !**

**Before installing the bearings, make sure that the shaft mounted parts behind the bearings are in place before installation.**

Since the bearing is a high precision component, it is important to avoid ingress of dust and foreign matter and hammering during cleaning and installation. Be extremely careful and ensure clean conditions exist during installation and assembly.

**ATTENTION !**

**The best way for bearing installation is heat shrinking. Knocking and hammering during installation should be absolutely avoided.**

The bearing should be heated in a bath of clean oil to a temperature of approx. 80°C or using an induction bearing heater with a temperature probe. After warming, slide the bearings in place quickly and nimbly so that it does not shrink onto the shaft before being fully in position. Take care to keep the bearing straight during installation and ensure it is properly seated against the shoulder. Maintain pressure against the shoulder for several seconds to ensure it does not slide back from the shoulder, or become “cocked” on the journal.

Grease the bearing after the temperature returns to normal, and then reassemble the motor.

---

## 5.6 Maintenance of sleeve bearing

### 5.6.1 Daily inspections

- (a) Ensure the volume and quality of lubricating oil are in compliance with specifications.

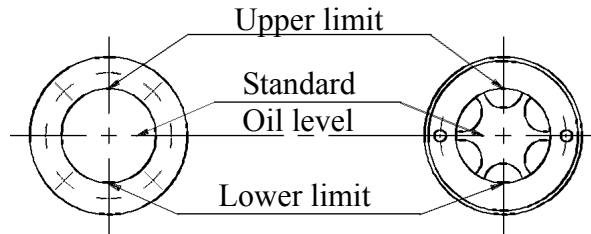

**Fig. 22**

- (b) Ensure there is motion of the oil ring and it is not clamped, but free to rotate.
- (c) The indicator of the shaft endplay should be restricted within the specified range of the red groove of the shaft or the  $\pm 3\text{mm}$  range of the drive-end shaft shoulder. Otherwise the bearing will be destroyed.

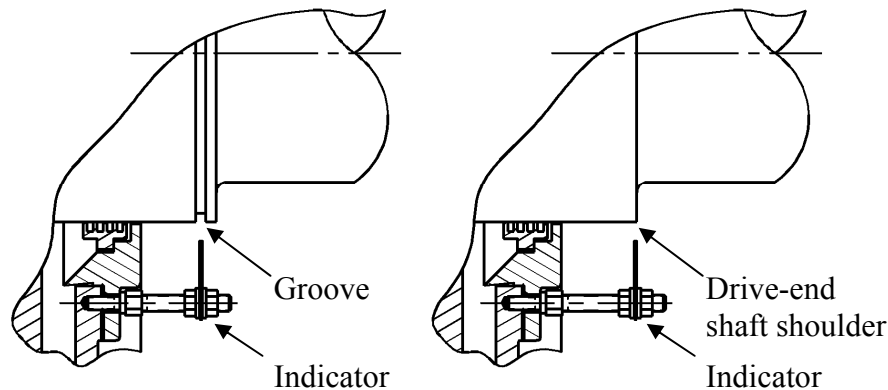

**Fig. 23**

### 5.6.2 Regular examination

- (a) Periodical change of oil

The oil reservoirs of self (not flood) lubricated bearings should be drained and refilled about every six (6) months. More frequent changes may be needed on high-speed (3600-rpm) motors or if severe oil discoloration or contamination occurs. In conditions where contamination does occur, it may be advisable to flush the reservoir with kerosene to remove any sediment before new oil is added. Proper care must be taken to thoroughly drain the reservoir of the flushing material before refilling with the new oil.

Refill the reservoir to the center of oil sight glass with a rust and oxidation inhibiting turbine grade oil. Refer to the outline and lubrication nameplate for the correct viscosity.

- (b) Quantity of lubrication oil

Please refer to the lubrication nameplate for oil quantity.

## (c) Oil viscosity for horizontal motors with sleeve bearings

Table 4 oil viscosity for horizontal motors

Oil viscosity	Equivalents		Range of pole
	ESSO	MOBIL	
ISO VG32 (150 SSU/100°F)	TERESSO 32	DTE OIL LIGHT	2 pole
ISO VG46 (200 SSU/100°F)	TERESSO 46	DTE OIL MEDIUM	4 pole
ISO VG68 (300 SSU/100°F)	TERESSO 68	OIL HEAVY MEDIUM	6 pole & above

Note: Where a lubrication nameplate is attached to the motor, use the lubrication oil it stipulates.

### 5.6.3 Disassembly



**Prior to disassembling, ensure the power supplies are disconnected and there are no moving parts.**

The bearing sleeve is of the spherically seated, self-aligning type. The opposite drive end bearing is normally insulated on larger motors (or when specified). On some motors, the insulation is bonded to the spherical seat of the bearing housing.

#### **ATTENTION !**

**Extreme care must be exercised in removing the bearing sleeve from the insulated support to avoid damaging this insulation.**

The following is the recommended procedure for removing the bearing sleeve:

- (a) Remove the oil drain plug in the housing bottom and drain the oil sump.
- (b) Remove all instrumentation sensors that are in contact with the bearing sleeve. These would include resistance temperature detectors, thermocouples, thermometers, etc.
- (c) Remove the socket head bolts holding the bearing cap and the inner air seal. The end cover plate must also be removed if the non-drive end bearing is being disassembled. Remove the bearing cap and top half of the inner air seal. Place them on a clean, dry surface to avoid damage to the parting surfaces.
- (d) Remove the top half of the bearing sleeve using suitable eyebolts in the tapped holes provided. Lift the bearing top straight up and avoid any contact with the shoulders of the shaft journals that might damage the thrust faces of the bearing. Place on a clean, dry surface taking care to prevent damage to either the parting surfaces or the locating pins that are captive in the top bearing half.
- (e) Remove the screws at the partings in the oil ring and dismantle the ring by gently tapping the dowel pin ends with a soft face mallet. Remove the ring halves and immediately reassemble them to avoid any mix up in parts or damage to the surface at the partings.

- (f) Pull up on the garter spring surrounding the floating labyrinth seal and carefully slip out the top half. Rotate the garter spring until the lock is visible. Twist counter-clockwise to disengage the lock, remove the garter spring, and then rotate the lower half of the seal out of the groove in the bearing housing. Note the condition of these floating labyrinth seals. If they are cracked or chipped, they must be replaced. Do not attempt to reuse a damaged seal.
- (g) To remove the bottom bearing half, the shaft must be raised a slight amount to relieve pressure on the bearing. On the drive end, this can be done by jacking or lifting on the shaft extension. Protect the shaft. On the non-drive end, jacking or lifting can be done using eye bolts threaded into the tapped holes provided in the shaft end.
- (h) Roll the bottom bearing half to the top of the shaft journal and then lift it using suitable eye bolts threaded into the holes provided. Again avoid any contact with the shaft shoulders that could damage the bearing thrust faces. Place the lower bearing half on a clean, dry surface to protect the parting surfaces.



**Use extreme care when rolling out the lower bearing half. Keep the hands and fingers well clear of any position where they might be caught by the bearing half if it were accidentally released and suddenly falls back to its bottom position. Serious personal injury could result.**

- (i) Protect the shaft journal by wrapping it with clean, heavy paper or cardboard.

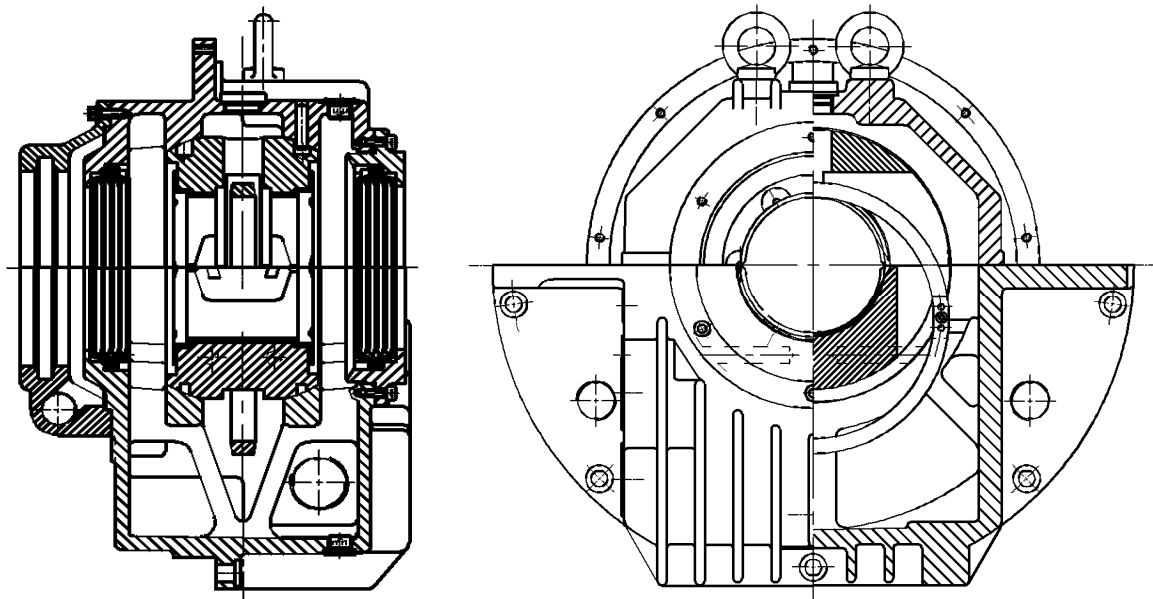

**Fig. 24**

#### 5.6.4 Reassembly

Bearing reassembly is basically a reverse of the disassembly procedures outlined above, with the following suggestion:

- (a) The interior of the bearing housing should be cleaned and then flushed with clean oil or kerosene.
- (b) The bearing halves and the shaft journal should be wiped clean using lint-free cloth soaked with clean oil.

- (c) All parts should be carefully inspected for nicks, scratches, etc., in any contact surfaces. Such imperfections should be removed by an appropriate method such as stoning, scraping, filing, etc., followed by thorough cleaning.
- (d) Before installing the halves of the floating labyrinth seal, observe their condition. Do not attempt to use a cracked or chipped seal. The bottom half seal has a set of drilled holes in its internal face. These must be placed at the bottom toward the inside of the bearing. Only in this position the accumulated oil can drain back into the housing.
- (e) Put a bead of Curil-T around the seal half O.D.'s on both sides adjacent to the angular spring groove. This will prevent oil from by-passing the seal around its outside.
- (f) Place the bottom seal half on top of the shaft and roll it into position. Install the top half and insert the garter spring pulling up on both ends to permit engaging the lock. Run a bead of Curil-T around the O.D.'s on both sides adjacent to the garter spring groove on this half also.
- (g) Carefully reassemble the two oil ring halves. Inspect the dowel pins for burrs and straightness and make any corrections required. Do not force the ring halves together. Excessive force may alter the roundness or flatness of the oil ring which can change its oil delivery performance. Once assembled, the oil ring should be measured to ensure it is round, if it is not it should be repaired or replaced.
- (h) Some of the pipe plugs in the housing are metric thread type. These are identified as those which have a copper, lead, or similar material washer. If these plugs are removed, be careful not to lose the washers. Before reassembly, inspect the washers and replace them as required.
- (i) Before installing the bearing cap, observe the position of the floating labyrinth seal. The "tab" must be on top to engage the pocket. Failure to position the seal properly will result in damage when the cap is assembled.

### **ATTENTION !**

- (1) Curil-T is the only approved compound for use in the assembly of the bearings on this motor. Other products may harden and impede the operation.**
- (2) During the reassembly of the bearing parts, a thin layer of Curil-T should be applied to all gaskets and machined interface surface. This suggestion does not apply to the machined surfaces of the bearing liner halves.**
- (3) When seating the bearing shell, apply a thin layer of lube oil at the spherical surface of the liner. Slowly roll the lower bearing liner into the bearing housing making sure the split surfaces of the liner and the housing are flush. Gradually lower the shaft onto the bearing. The weight of the shaft will help rotate the bearing liner so that the babbitt surface of the liner will match the slope of the journal. Sometimes it is required to use a rubber mallet to tap lightly on the bearing housing while slowly rolling the shaft to help this seating operation.**

#### **5.6.5 Oil viscosity for vertical motors**

Bearing Type	Oil viscosity	Range of pole
RENK Vertical Bearing Inserts Type EV or Kingsbury Type	ISO VG68 (300 SSU/100°F)	4 pole and above

## 5.7 Maintenance of slip ring (For Wound Rotor only)



Ensure motor is disconnected from power supplies and there are no accessible moving parts before maintenance operation.

### 5.7.1 Adjustment of carbon brush

(a) Brush pressure for normal operation :

- Electro-graphite brush
  - 160 g/cm<sup>2</sup> ±10% (for slip ring with spiral groove)
  - 200 g/cm<sup>2</sup> ±10% (for slip ring without groove)

When frequent vibrations are evident or the brush is small (area below 0.5 cm<sup>2</sup>), the pressure should be greater than as shown.

(b) Adjustment of brush pressure :

The brush pressure should be adjusted to keep normal operation as it wears.

- The brush pressure may be reduced after use, so it is necessary to re-adjust. For adjustment, please turn adjusting screw, pressure adjusting pin or pressure adjusting plate as shown in Fig.25 to obtain the correct tension ( $=0.23 \times \text{brush cross sectional area in cm}^2$ ) ±10% kg.

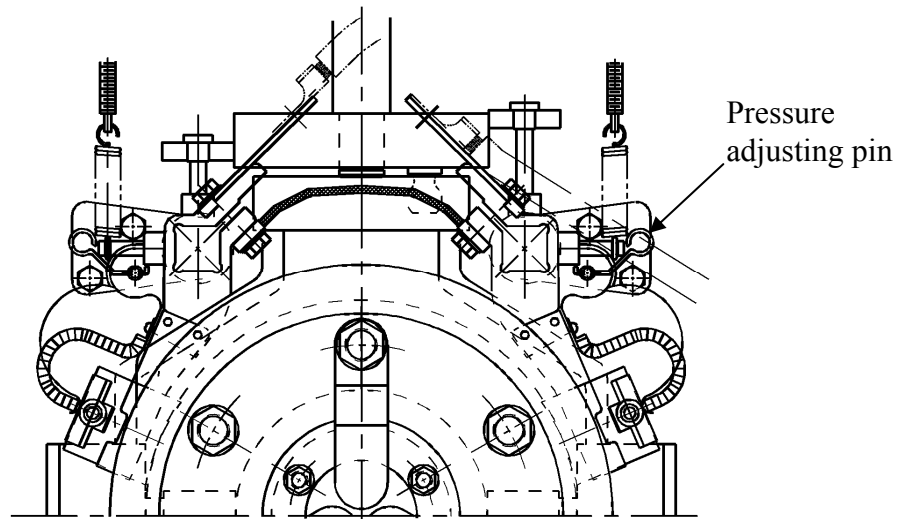

Fig. 25

(c) Brush pressure need not be adjusted if constant force spring is used as shown in Fig.26 and Fig. 27.

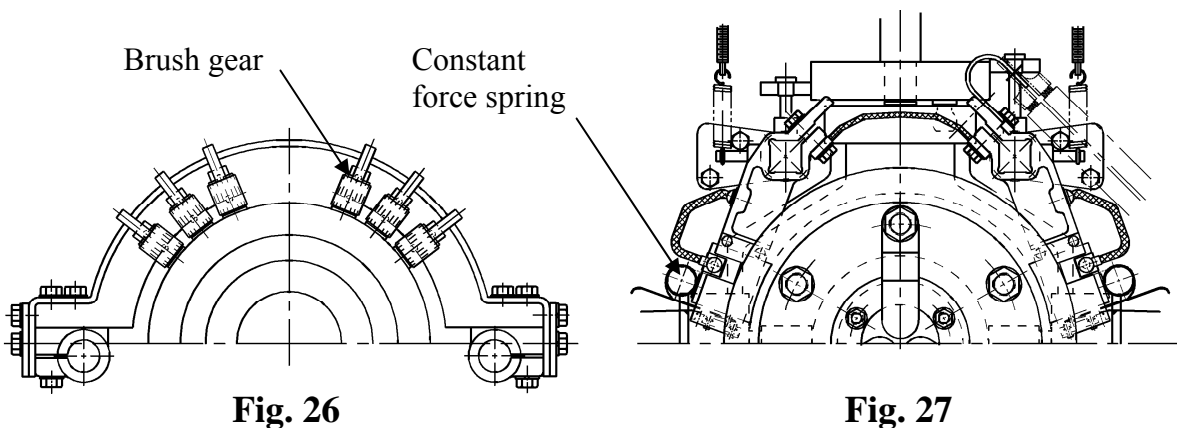

Fig. 26

Fig. 27

### 5.7.2 Brush replacement

The carbon brush is a part of the equipment which is easily worn away, replace it after it is worn to 1/2~3/5 of original size.

(a) Brush material

The brush material is important to the performance of the motor. Only the most appropriate materials are chosen by TECO-Westinghouse, and are listed on the nameplate of motor. It is important to know this when you replace the brush, only the recommended type and grade should be used.

(b) Dimensions

Brush, holder and gap between them, please refer to CNS 2322 C4051 or JIS C2802.

**ATTENTION !**

**The gap between a brush and its holder is important for good performance and safety of the motor.**

(c) Adjustment of new brushes (Shown in Fig.28)

- (1) Polish the new brush with sandpaper until it assumes the appropriate contour of the slip ring which it touches.
- (2) Place sandpaper (JIS R6252 NO.40.....50) on the slip ring with the abrasive face of the paper against the brush to induce a closer contact by rubbing against each other.
- (3) Repeat item 2 with fine sand-paper (JIS R6252 NO. 100 to 200) until the contact surface between brush and slip ring exceeds 80%.
- (4) Finally, clean the contaminated slip ring and brush with clean cloth or vacuum.

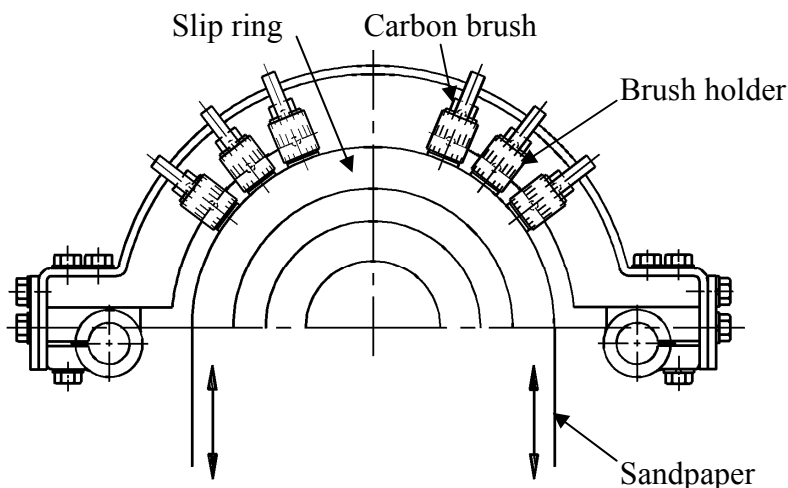

**Fig. 28**

## 5.8 Maintenance of non-reverse ratchet mechanism (For Vertical high Thrust Motor only)

### 5.8.1 Non-reverse ratchet mechanism

In the pump piping system, a check valve and a stop valve should be installed in the discharge line. The check valve, placed between the pump and the stop valve, is to protect the pump from reverse flow and excessive back pressure. The stop valve is used in priming, starting and when shutting down the pump. It is advisable to close the stop valve before stopping the pump. This is especially important when the pump is operated against a high static head.

TECO-Westinghouse vertical high thrust motors are equipped with non-reverse ratchet (N.R.R.) mechanism only when requested by the pump manufacturer. Typical construction of N.R.R. mechanism is shown as Fig.29 below.

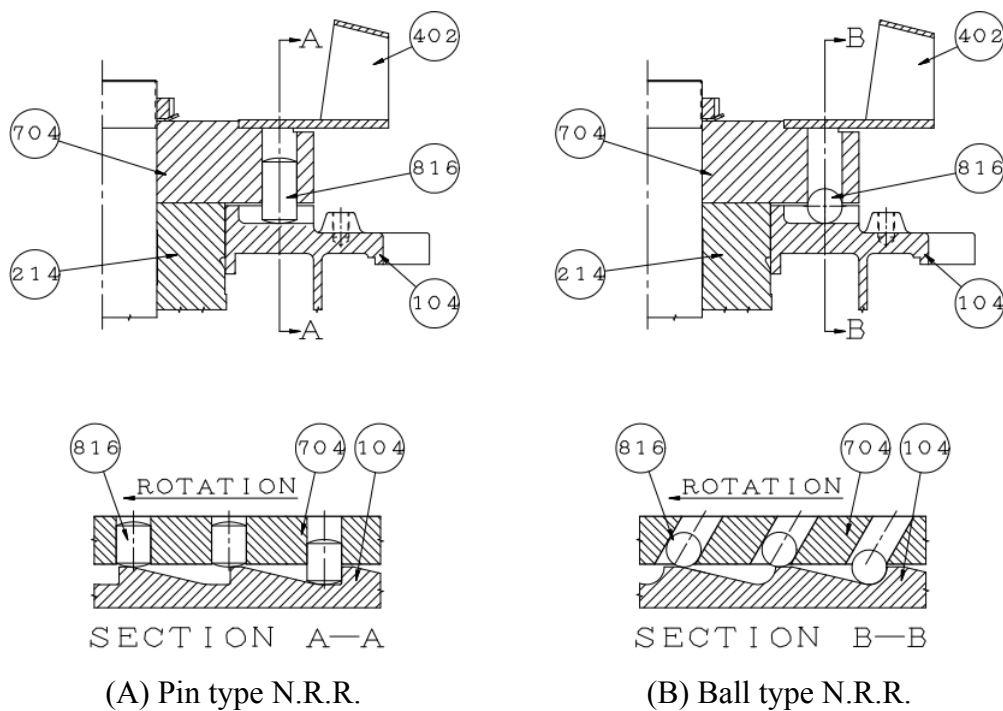

ITEM	NAME
104	RATCHET
214	BEARING SEAT
402	EXTERNAL FAN
704	RATCHET PIN CARRIER
816	RATCHET PIN(BALL)

**Fig. 29**

The N.R.R. mechanism keeps the pump and motor from rotating in the reverse direction. Thus prevents damage from over speeding and damage to water-lubricated pump shaft bearings when, on shutdown, the falling water column tends to drive the pump in the reverse direction.

In normal operation, the ratchet pins are lifted by the ratchet teeth and are held clear by centrifugal force and friction as the motor comes up to speed. When power is removed, the speed decreases and the pins fall. At the instant of reversal, a pin will catch in a ratchet tooth and prevent backward rotation.

### 5.8.2 Service life

The service life of ratchet pins depends not only on the reverse shock load between the pin and ratchet tooth when pump stopped but also the frequency of pump starting and stop in application.

Over time the pins can become deformed due to this reverse shock load, causing the up and down motion of ratchet pins to become sluggish or jammed and unusual noises will arise.

The recommended replacement period for these ratchet pins is every three (3) years. If the reverse shock load is greater than 30% of motor rated torque or the starting frequency is more than twice per day, then the replacement period is to be halved.

#### **ATTENTION !**

**The check valve and stop valve in the discharge line should be regularly inspected and maintained to assure the normal function of these valves. This is important to protect the pump and motor from damage and increase the service life of the N.R.R. mechanism.**

## 5.9 Dismantling and Assembly Procedure

Please see the drawing in Appendix 4.

Brackets w/anti-friction bearing	Dismantling brackets	Assembly
TEFC	<ol style="list-style-type: none"> <li>1. Remove the fan cover &amp; outer fan.</li> <li>2. Remove securing bolts between the bearing cover-outer (22) and the bracket (18).</li> <li>3. It may be necessary to remove any seals / grease flingers / temperature sensors etc attached to the shaft or housings.</li> <li>4. Pull out the bearing cover-outer (22) very carefully.</li> <li>5. Remove securing bolts hold between the bracket (18) and frame (12).</li> <li>6. Pull out the bracket (18) gently.</li> </ol>	<ol style="list-style-type: none"> <li>1. Check the bearing assembly. Keep each part very clean.</li> <li>2. Tighten securing bolts by reverse step of dismantling.</li> </ol>

---

## **5.10 Records of operation and maintenance**

### **5.10.1 Objective**

- (a) Fully understand the purpose of the motors in operation and discover any abnormalities in advance.
- (b) Prevent negligence and omissions in maintenance.
- (c) Map pertinent maintenance plans after fully understanding the operation of the motor.
- (d) Assess the life of the depreciating parts to determine the amount of spare parts to be kept.
- (e) Plan the amount of spare motors and replacement parts to repair the motors in operation according to actual situation and schedule.

### **5.10.2 Records of operation**

- (a) It is advisable to use a primed form with yes/no or right/wrong selections for the operator to easily fill out.
- (b) Principle contents :
  - (1) Serial number of machine.
  - (2) Load machine type.
  - (3) Models and specifications of motors.
  - (4) Three-phase voltage.
  - (5) Three-phase current.
  - (6) Temperature of a motor and bearings when in operation.
  - (7) Ambient temperature, humidity, weather, date and time.
  - (8) Time of start and stop.
  - (9) Special remarks.
  - (10) Operator's name.

### **5.10.3 Maintenance records**

- (a) It is advisable to use a primed form with yes/no or right/wrong selections for the operator to easily fill out.
  - (b) Principle contents :
    - (1) Serial number of machine.
    - (2) Load machine type.
    - (3) Models and specifications of motors.
    - (4) Ordinary operating conditions and data.
    - (5) Cause, date and disposition measures at breakdown.
    - (6) Quantity and name of replaced spare parts.
    - (7) Date of maintenance and initial operation.
    - (8) Items and date of maintenance.
    - (9) Special remarks.
    - (10) Name of maintenance personnel.
-

## 6. FAULT FINDING AND RECOGNITION

Type of Breakdown	Symptoms	Possible causes	Remedies
Fail to start without load	Motionless and soundless	Power-off	Consult power company
		Switch-off	Switch-on
		No fuse	Install fuse
		Broken wiring	Check wiring and repair
		Broken lead	Check wiring and repair
		Broken windings	Check windings and repair
	Fuse blowing. (Automatic switch trips off, slow start with electromagnetic noise)	Short circuit of circuit switches	Check circuit switches and replace
		Incorrect wiring	Check wiring according to nameplate
		Poor contact at terminals	Lock tightly
		Windings grounded	Factory repair
		Broken windings	Factory repair
		Poor contact of circuit switches	Check and repair
		Broken wiring	Check and repair
		Poor contact of starting switches	Check and repair
Short circuit of starting switches	Check and repair		
Incorrect connections of starting switches	Connect according to nameplate		
Loading after start	Fuse blowing. Fail to restart due to trip-off of automatic switch	Insufficient capacity of fuse	Replace fuse if wiring permits
		Overload	Lighten load
		High load at low voltage	Check circuit capacity and reduce load
	Overheating motor	Overload or intermittent overload	Lighten load
		Under-voltage	Check circuit capacity and power source
		Over-voltage	Check power source
		Ventilation duct clogged	Remove the foreign matter in the duct
		Ambient temperature exceeds 40°C	Correct insulation class F, or lower ambient temperature.
		Friction between rotor and stator	Factory repair
		Fuse blown (Single-phase rotating)	Install the specified fuse
		Poor contact of circuit switches	Check and repair
		Poor contact of circuit starting switches	Check and repair
		Unbalanced three-phase voltage	Check circuit or consult power company

Kinds of Breakdown	Symptoms	Possible causes	Remedies
Loading after start	Speed falls sharply	Voltage drop	Check circuit and power source
		Sudden overload	Check machine
		Single-phase rotating	Check circuit and repair
	Switch overheat	Insufficient capacity of switch	Replace switch
		High load	Lighten load
	Bearing overheating	Lack of oil	Add oil
		Lack of grease	Add grease
		Misalignment between motor and machine shafts	Re-align
		Over speed of bearing outer-ring	Adjust bracket
		High bearing noise	Replace the damaged bearing
Noise	Electromagnetic noise induced by electricity	Occurrence from its first operation	May be normal
		Sudden sharp noise and smoking	Short circuit of windings Should be repaired at factory
	Bearing noise	Churning sound	May be normal noise from grease circulating through the bearing
		Rattling noise as result of poor lubrication	Add Grease
		Larger noise	Inspect cause -replace the damaged bearing
	Mechanical noise caused by machinery	Loose belt sheave	Adjust key and lock the screw
		Loose coupling or skip	Adjust the position of couplings, lock key and screw
		Loose screw on fan cover	Lock fan cover screw tightly
		Fan rubbing	Adjust fan position
		Rubbing as a result of ingress of foreign matters	Clean motor interior and ventilation ducts
		Wind noise	Noise induced by air flowing through ventilation ducts
		Induced by conveyance machine	Repair machine
	Vibration	Electromagnetic vibration	Short circuit of windings
Open circuit of rotor			Factory repair
Mechanical vibration		Unbalanced rotor	Factory repair
		Unbalanced fan	Factory repair
		Broken fan blade	Replace fan
		Unsymmetrical centers between belt sheaves	Align central points
		Central points of couplings not in alignment	Adjust the alignment between motor and driven equipment
		Improper mounting installation	Check mounting and alignment
		Motor mounting bed is not strong enough	Reinforce mounting bed
		Mounting bed vibration caused by near machines	Eliminate the vibration source near motor

Remarks:

- (1) Circuit switches: These include knife switches, electromagnetic switches, fuse and other connection switch etc.
- (2) Starting switches: These include Delta-Star starters, compensate starters, reactance starters, resistor starters, starting controllers etc.

## 7. RECYCLE

### 7.1 Introduction

TECO obey its environmental and protection policies. TECO has always been committed through the use of recyclable and life cycle analysis of the results to improve environmental protection products. Products, production processes or flow designs are all reflected the concept of environmental protection. TECO's environmental management system through the ISO 14001 certification is used to implement an environmental policy tool.

The following guidelines only deal with the suggestions of environmental treatment on the equipments. Customer shall be responsible for compliance with local regulations. This manual may not include some of the customer's specific content. Project document provides additional documentation.

### 7.2 Materials Average Content

When producing electrical equipments, the average material content used are as follows:

Material	Die-casting frame Induction machinery	Steel plate frame Induction Machinery
Steel	45 – 56 %	79 - 83 %
Copper	8 – 10 %	12 – 14 %
Cast iron	32 – 43 %	1 – 3 %
Aluminum	0 – 5 %	0 - 1 %
Insulation materials	1 - 2 %	2 – 4 %
Stainless steel	Below 1 %	Below 1 %
Other	Below 1 %	Below 1 %

### 7.3 Packing Materials Recycling

When the equipments arrived to the place, the packing materials should be removed.

- All wood-made packing materials can be burned.
- The packing materials used with impregnated wood at sea shipping for some country must be recycled according to local regulations.
- The plastic materials around equipments can be recycled.
- The anticorrosive agent covered on the surface of equipments can be cleaned by gasoline-based cleaner or wipers. Treating the wipers must be complied with local regulations.

### 7.4 Equipment of disassembling

Disassembling equipment is a basic operation because equipment is assembled by bolts. However, due to the heavy weight of equipment, the operator must be required to have received training in handling the transportation of heavy loads to avoid any danger.

---

## **7.5 Classification of different materials**

### **7.5.1 Frame, Bracket (bearing housing), Cover and Fan**

These parts are made of structural steel and can be recycled according to local regulations. All of auxiliary equipment, cables and bearings must be removed before melting.

### **7.5.2 Parts with electrical insulation**

The stator and rotor are the main part of machinery included electrical materials. Some auxiliary parts also included similar materials and should be used the same methods to dispose. These materials include each insulator in terminal box, exciter, transformer with adjustable voltage and current function, cables, wires, corona discharger and capacitor. Some parts are used for synchronous machineries and some used for few equipments.

All of these parts are in an inert state when equipments were completed.

Some parts (especially the components into stator and rotor) including a large number of copper can be separated by appropriate heat treatment and the organic adhesive materials in insulation materials can be gasified. In order to ensure proper gas combustion, burner should provide an appropriate supplementary burner. In the combustion process of heat treatment, following conditions are recommended to minimize the material distributed processing:

Temperature of Heat treatment : 380- 420°C ( 716- 788°F )

Duration : Processing object should be kept at that temperature for at least 5 hours when reaching to 90% of target temperature.

Supplementary gas combustion temperature for adhesives smoke: 850-920 ° C (1562-1688 ° F)

Flow rate: adhesives smoke in the combustion chamber should be kept at least three seconds

Note: The distribution of substances include O<sub>2</sub>, CO, CO<sub>2</sub>, NO<sub>x</sub>, C<sub>x</sub>H<sub>y</sub> gas and micro-particles.

User shall be responsible to ensure that the process comply with local regulations.

Note: You should pay particular attention to thermal processes and heat treatment equipment maintenance, so as not to bring fire or explosion hazard. Since this work will use a variety of devices, so TECO cannot provide a detailed maintenance guideline for treatment process or equipment, customers will be responsible for dealing with these issues.

### **7.5.3 Permanent Magnet**

If permanent magnet synchronous machineries will be totally melted, it's no need to deal with the permanent magnets.

In order to achieve a more complete recovery and removal of equipment or if the rotor will be sent out after recovery, we suggest doing permanent magnet demagnetization. Rotor can be heated in the

---

furnace until the temperature of a permanent magnet reaches 300 °C (572 °F) to achieve degaussing purpose.



**Open or disassemble permanent magnet synchronous machinery or remove the rotor of such equipment will produce stray magnetic fields. It may interfere with or damage to other electrical or electromagnetic devices and components, such as cardiac pacemakers, credit cards and more.**

#### **7.5.4 Hazardous Waste**

The grease in oil lubrication system is hazardous waste and must be treated by local regulations.

#### **7.5.5 Buried Waste**

All insulation materials can be treated as landfill waste.

---

## Appendix 1. Daily inspection

Checking point	Checking item	Description or inspection parts	Method	Criteria or notes
1. Bearing	Oil supply	Oil quantity	Check oil level from oil sight gauge.	In the middle of oil sight gauge.
		Oil pressure (forced oil lubrication only)	Check oil supply pressure gauge near inlet pipe or supply unit.	Within $\pm 20\%$ of specified pressure.
		Oil ring rotation (horizontal sleeve bearing only)	Check oil ring from window at 12 o'clock.	Rotating smoothly
	Oil leakage	Shaft · labyrinth seal · piping connection · parting line of housing	Inspect by eye and touch by hand.	Dampness around housing is normal. But oil accumulation on floor should be checked.
	Temperature	Bearing temperature detector	Check the value is the same as normal.	Recommendation : See 4.2.8
	End play	Axial fluctuation of shaft	Inspect by eye.	The shaft shoulder should not touch the liner.
		Magnetic center	Inspect the magnetic center pointer on drive end.	$\pm 3\text{mm}$
	Vibration	Ref to 4.2.9	If the vibration level is higher than normal, please measure the spectrum by instrument.	Analyze the spectrum.
Noise	Ref to 4.2.9	Listen for unusual noise	Assess noise , stop and inspect if necessary	
2. Stator	Temperature	Winding temperature detector	Check the value is the same as normal.	Recommendation : See 4.2.10
	Load	Voltage · current	Check the value from control panel	Voltage variation < 10% Current < rated current
3. Cooler	Water supply	Water quantity	Check the water flow relay or indicator & temperature.	The water flow rate and temperature limitations are shown on outline drawing.
4. Filter	Dust or pollution	Clean filter	Clean by fresh water	Clean filter
5. Others	Odor	Windings & Bearings	Check winding and bearing temperature monitors	Check load / cooling air flow, oil condition.

## Appendix 2. Monthly inspection

Checking point	Checking item	Description or inspection parts	Method	Criteria or notes
1. Bearing	Oil supply	Oil quantity	Check oil level from oil gauge.	In the middle of oil gauge. If the oil quantity is low , please add oil and check for leaks
	Oil leakage	Shaft 、 labyrinth seal 、 piping connection 、 parting line of housing	Inspect by eye and touch by hand.	If oil is leaking, it is important to find the root cause.
2. Stator	Temperature	Winding temperature detector	Check the value if the same as normal.	Recommendation : See 4.2.10
	Appearance	Bolts/nuts for bracket or frame etc.	Inspect by eye and touch by hand.	Re-tighten all loose.
	Resistance	Winding	500VDC/1000VDC megger. Once every three months at least.	Ref to “Operation” 4.1.2 measurement of insulation resistance.
3. Cooler	Water supply	Water quantity	Check the water flow relay or indicator & temperature.	The water flow rate and temperature limitations are shown on outline drawing.
4. Coupling	Appearance	Bolts/nuts	Inspect by eye and touch by hand.	Re-tighten all loose bolts.
5. Space heater	Resistance	Heater wire	500VDC megger.	Ref to “Operation” 4.1.2 measurement of insulation resistance.

### Appendix 3. Regular Inspection

item	Checking point	Description	Regular inspection			
			In situ Exterior surface inspection	In situ Open inspection	Removed for Disassembly inspection	
1. Inspection before disassembly	(1)	Vibration	Measure and record the vibration levels for reference	<input type="radio"/>	<input type="radio"/>	<input type="radio"/>
	(2)	Temperature	Record bearing, winding & ambient temperature for reference.	<input type="radio"/>	<input type="radio"/>	<input type="radio"/>
	(3)	Coupling	Measure the mounting and shaft end dimensions. Check if any bolts are loose. Check if there are any mounting hole, key & keyway deformation.			<input type="radio"/>
	(4)	Alignment	Check and record the alignment for reference			<input type="radio"/>
	(5)	Anchor bolt, mounting bolt & nut	Check if there are any parts loose. Check condition of all nuts , bolts, Replace if defective.		<input type="radio"/>	<input type="radio"/>
	(6)	Adjusting shims	Check if rusty, damaged and replace if damaged.			<input type="radio"/>
	(7)	Shaft vibration	Measure the shaft vibration value and record.			<input type="radio"/>
	(8)	Foundation level	Check for any deformation that may have occurred.			<input type="radio"/>
	(9)	Air gap	Measure this value and record in 3 places at least for each end.			<input type="radio"/>
2. Sleeve bearing inspection	Sleeve bearing	According to RENK “Instructions for Maintenance and Inspection”.		<input type="radio"/>	<input type="radio"/>	
3. Stator inspection	(1)	Winding resistance	Use 500VDC/1000VDC megger to measure and record results.	<input type="radio"/>	<input type="radio"/>	<input type="radio"/>
	(2)	Winding appearance	Check if any dust or oil contamination on winding coil			<input type="radio"/>
	(3)	Coil end	Check coils for loose blocking, lashings, end rings.			<input type="radio"/>
	(4)	Coil insulation	Check coil insulation material for wear, discolouration or damage			<input type="radio"/>
	(5)	Cable lead	Check if lead insulation broken, cracked or damaged.			<input type="radio"/>
	(6)	Terminal lug	Check for loose or damaged lugs or terminals.			<input type="radio"/>
	(7)	Coil wedge	Check for loose or damaged slot wedges.			<input type="radio"/>
	(8)	Air guide	Check each bolt & nut to see if any is loose.			<input type="radio"/>

### Appendix 3. Regular Inspection (continue)

item	Checking point	Description	Regular inspection			
			In situ Exterior surface inspection	In situ Open inspection	Removed for Disassembly inspection	
4. Rotor inspection	(1)	Rotor appearance	Check if any dust or oil contamination is on rotor.		○	
	(2)	Rotor bar	Check for loose or damaged bars Check rotor bar end ring welds.		○	
	(3)	Rotor core	Check for loose or damaged laminations.		○	
5. Fan	Fan	Check welded portions for cracks, bolts & nuts, any built up dirt or rust.			○	
6. Inspection before operation	(1)	Winding resistance	Use 500VDC/1000VDC megger to measure, record results.	○	○	○
	(2)	Supply lead connection	Check all incoming supply leads correctly connected.		○	○
	(3)	Protection relay	Check protection relay in normal operation.	○	○	○
	(4)	Lubrication oil	Oil level at the middle of oil gauge. Oil inlet pressure correct and oil drains smoothly.	○	○	○
	(5)	Alignment	Check and record the alignment.			○
	(6)	Anchor bolt & mounting bolt	Check all mounting bolts are securely tightened.		○	○
	(7)	Driven equipment	Check if all driven equipment is ready for operation.	○	○	○
	(8)	Cooling water	Check cooling water flow rate & quantity.	○	○	○
7. Inspection before starting	(1)	Rotational direction	Check rotational direction.	○	○	○
	(2)	Oil ring	Check if oil ring runs smoothly.	○	○	○
	(3)	Noise	Check there is no abnormal noise.	○	○	○
	(4)	Vibration	Check if vibration is normal.	○	○	○
	(5)	Bearing temperature	For test run, please keep monitoring for 2hrs at least.	○	○	○
	(6)	Oil level	Check oil level.	○	○	○
	(7)	Current	Make sure current is below rated value shown on nameplate.	○	○	○

**Note :**

- (a) Disassembly inspection : removing the rotor to inspect the stator & rotor.  
Recommendation : every four (4) years, but depends on operation environment conditions & machine type.
  - (b) Open inspection : inspect the maximum possible portions without removing rotor.  
Recommendation : every two (2) years, but depends on operation environment conditions & machine type.
  - (c) Exterior surface inspection  
Recommendation : every year.
-

### Appendix 4. Typical motor cross sectional drawings : SCIM, TEFC

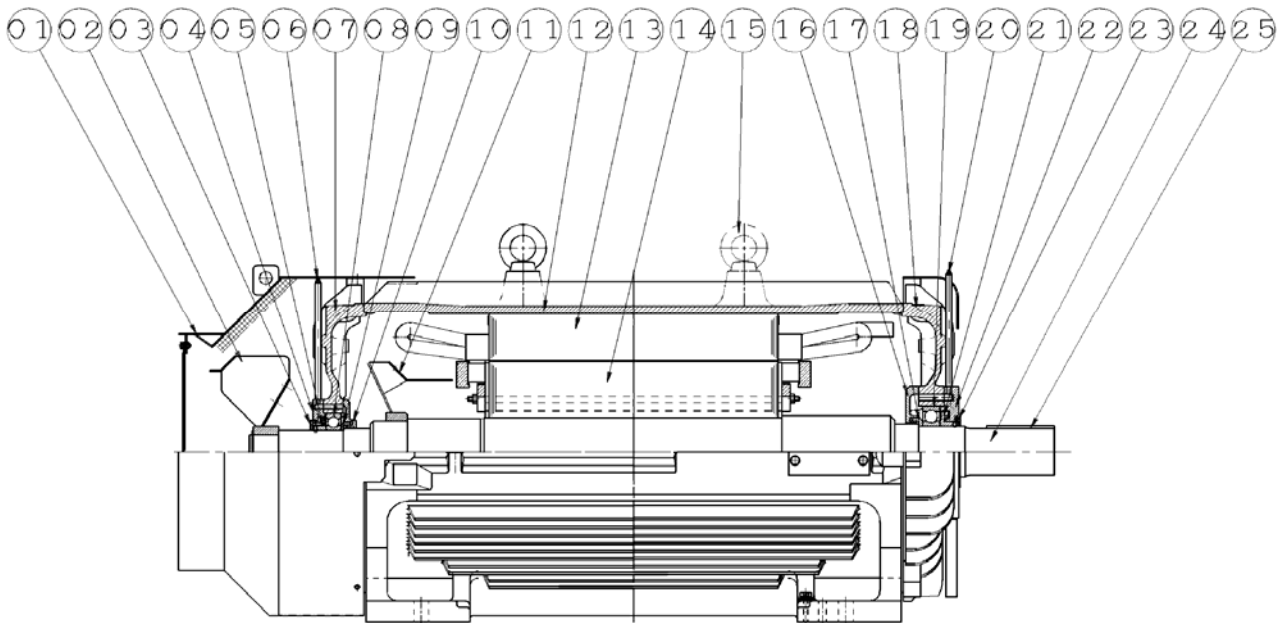

Item	Name	Item	Name
01	FAN COVER(N.D.E)	14	ROTOR
02	EXTERRAL FAN	15	EYE BOLT
03	DUST FLINGER	16	BEARING COVER-INNER
04	BEARING COVER-OUTER	17	GREASE FLINGER
05	GREASE FLINGER	18	END BRACKET
06	GREASE NIPPLE	19	BEARING
07	END BRACKET	20	GREASE NIPPLE
08	BEARING	21	GREASE FLINGER
09	GREASE FLINGER	22	BEARING COVER-OUTER
10	BEARING COVER-INNER	23	DUST FLINGER
11	INNER FAN	24	SHAFT
12	FRAME	25	SHIFT END KEY
13	STATOR		

## Appendix 5. Typical motor cross sectional drawings : ODP

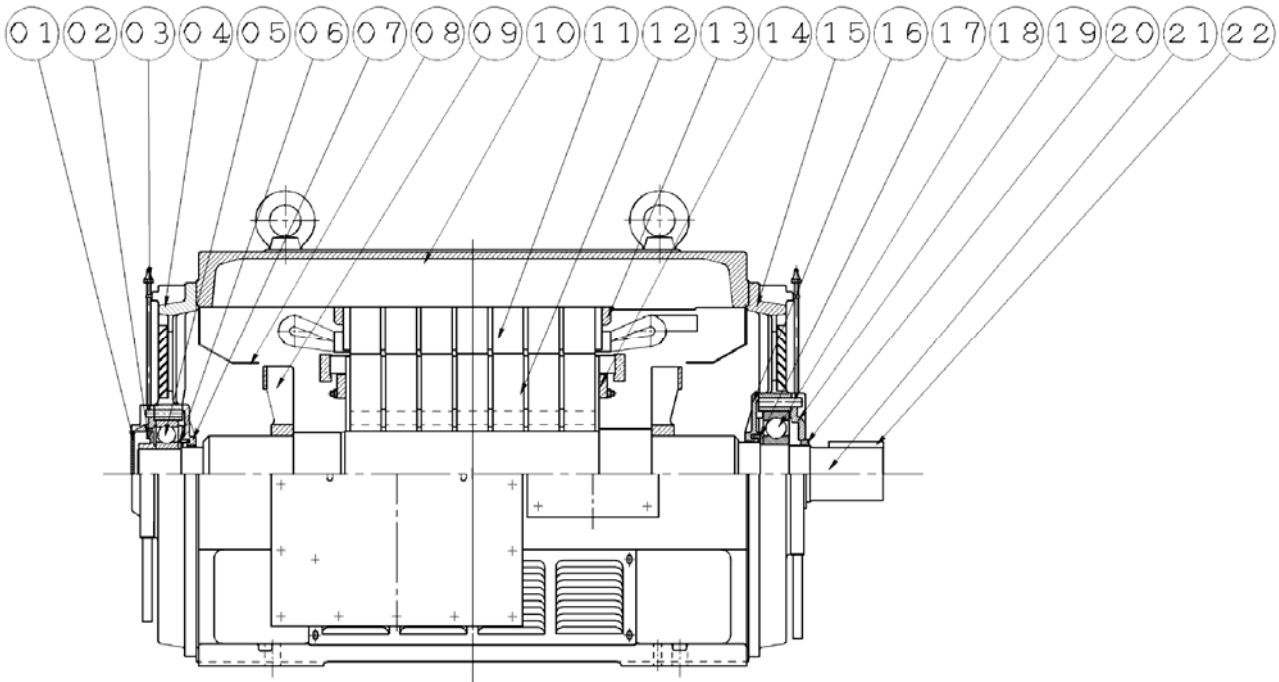

Item	Name	Item	Name
01	BEARING COVER-OUTER	12	R CORE
02	GREASE FLINGER	13	RETAINER RING-S
03	GREASE NIPPLE	14	RETAINER RING-R
04	BRACKET	15	BRACKET
05	BEARING	16	BEARING COVER-INNER
06	STOP RING-BEARING	17	STOP RING-BEARING
07	BEARING COVER-INNER	18	BEARING
08	AIR GUIDE	19	BEARING COVER-OUTER
09	INNER FAN	20	INPRO SEAL
10	FRAME	21	SHAFT
11	S CORE	22	KEY

## Appendix 6. Typical motor cross sectional drawings : SCIM, TEWC

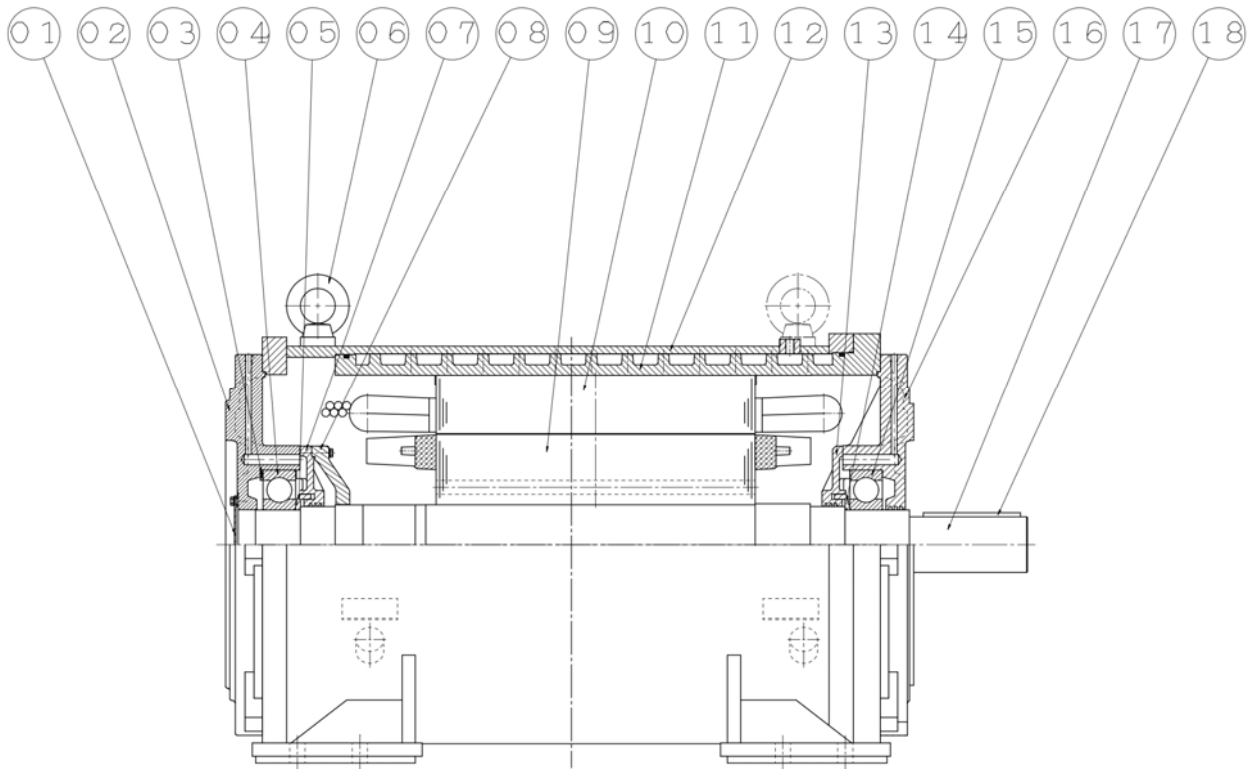

Item	Name	Item	Name
01	COVER	10	S CORE
02	FLANGE-BRACKET	11	FRAME-INNER
03	PRE-LOAD SPRING	12	FRAME-OUTER
04	BEARING	13	BEARING COVER-INNER
05	GREASE FLINGER	14	GREASE FLINGER
06	EYE BOLT	15	BEARING
07	BEARING COVER-INNER	16	FLANGE BRACKET
08	BEARING COVER-INNER	17	SHAFT
09	ROTOR	18	KEY

## Appendix 7. Typical ball bearing construction drawing

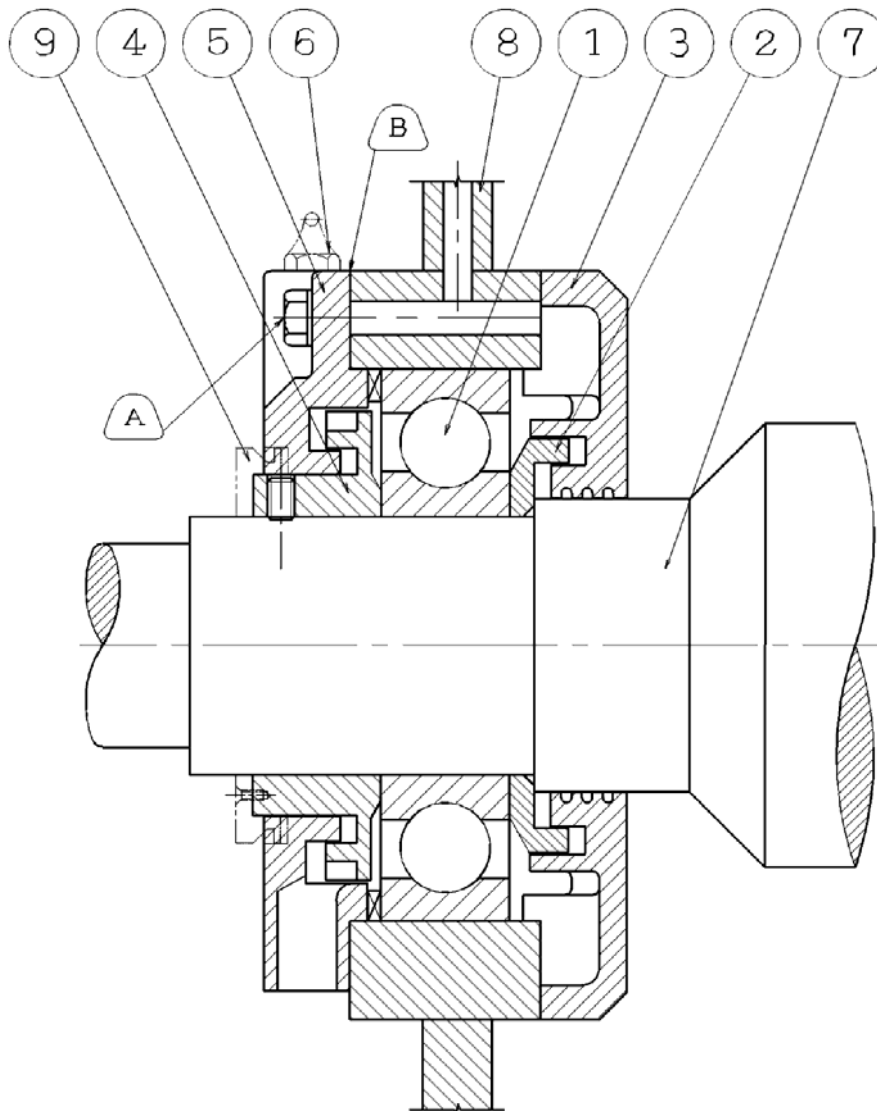

Item	Name	Item	Name
1	Ball Bearing	6	Grease Nipple & Pipe
2	Grease Flinger-Inner	7	Shaft
3	Bearing Cover-Inner	8	Bracket
4	Grease Flinger-Outer	9	Dust Flinger
5	Bearing Cover-Outer		

Please be noted :

1. Use sealing compound on screws (A) and the surface between parts (B).
2. In order to avoid abnormal bearing noise, please fill new grease as full as possible between races during the change process of bearing.

## Appendix 8. Typical roller bearing construction drawing

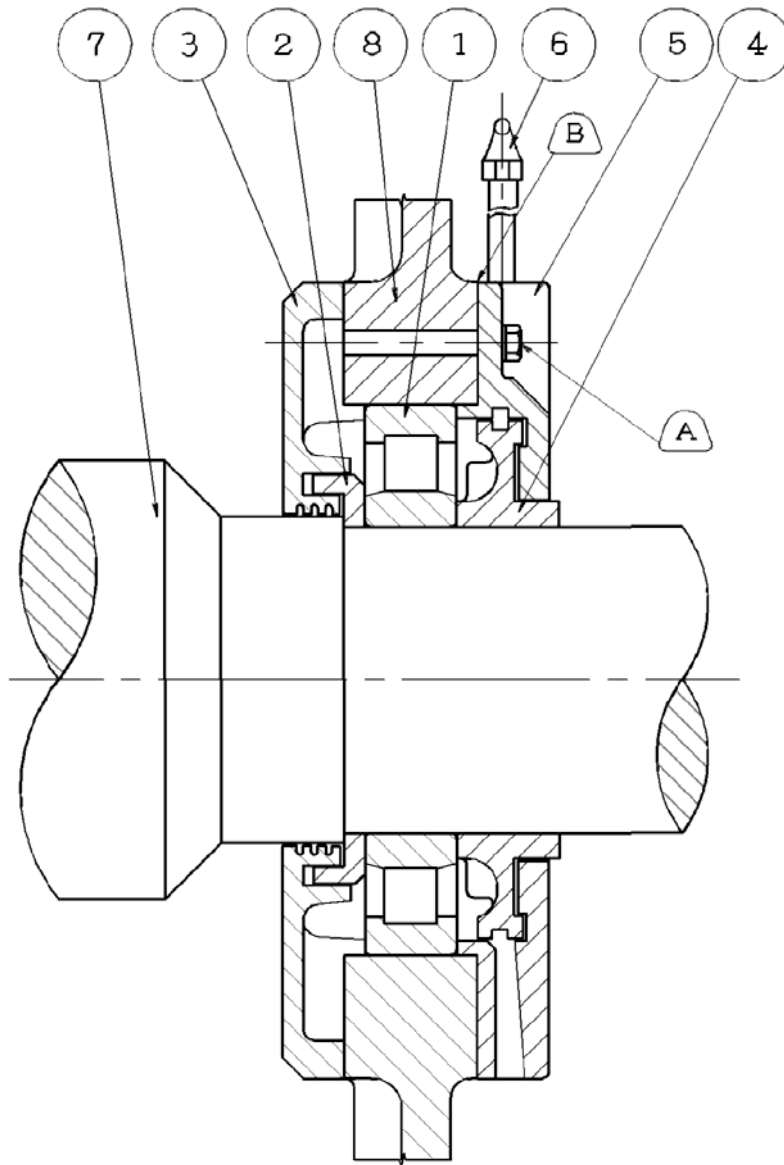

Item	Name	Item	Name
1	Roller Bearing	5	Bearing Cover-Outer
2	Grease Flinger-Inner	6	Grease Nipple & Pipe
3	Bearing Cover-Inner	7	Shaft
4	Grease Flinger-Outer	8	Bracket

Please be noted :

1. Use sealing compound on screws (A) and the surface between parts (B).
2. In order to avoid abnormal bearing noise, please fill new grease as full as possible between races during the change process of bearing.

## Appendix 9. Typical ball bearing with insulation bushing construction drawing

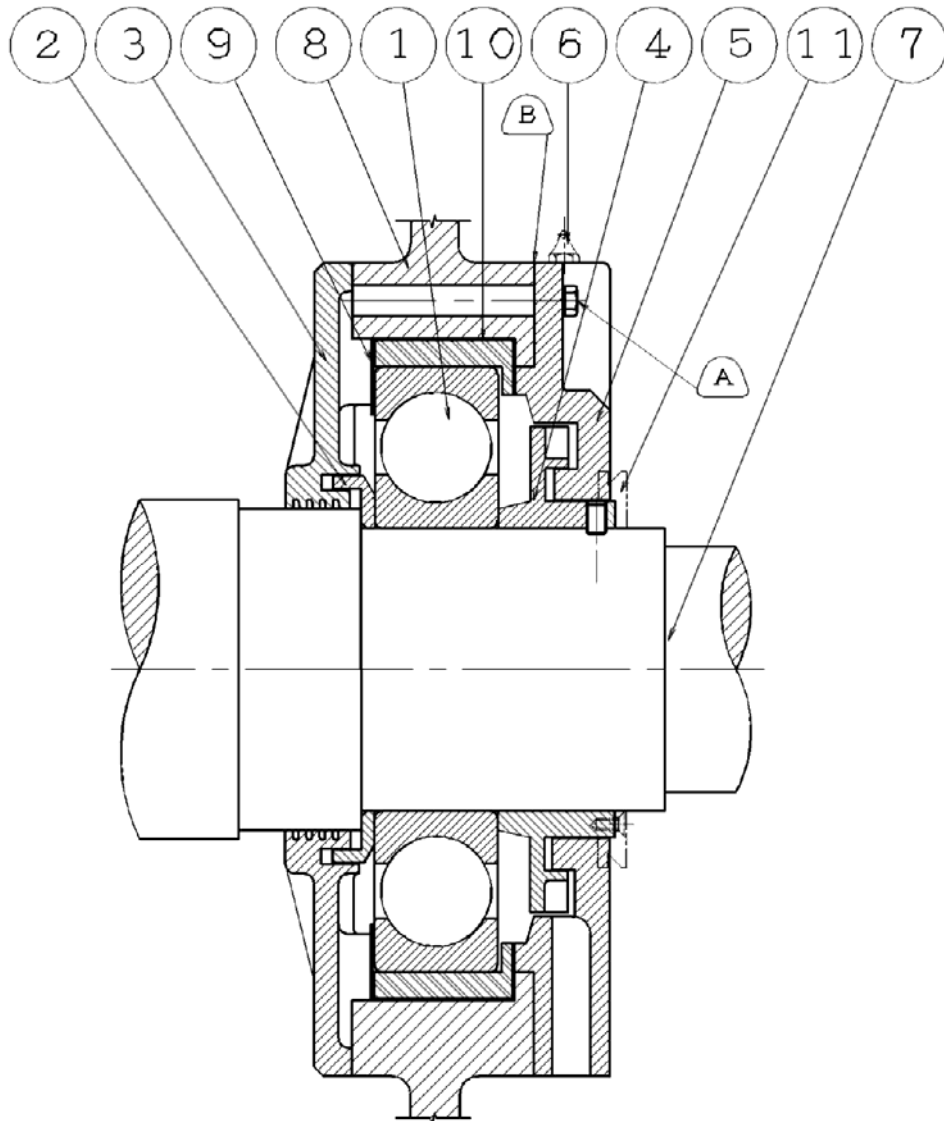

Item	Name	Item	Name
1	Ball Bearing	7	Shaft
2	Grease Flinger-Inner	8	Bracket
3	Bearing Cover-Inner	9	Insulation Plate
4	Grease Flinger-Outer	10	Insulation Bushing
5	Bearing Cover-Outer	11	Dust Flinger
6	Grease Nipple & Pipe		

Please be noted :

1. Use sealing compound on screws (A) and the surface between parts (B).
2. In order to avoid abnormal bearing noise, please fill new grease as full as possible between races during the change process of bearing.

## Appendix 10. Typical thrust bearing assembly drawing (vertical machine)

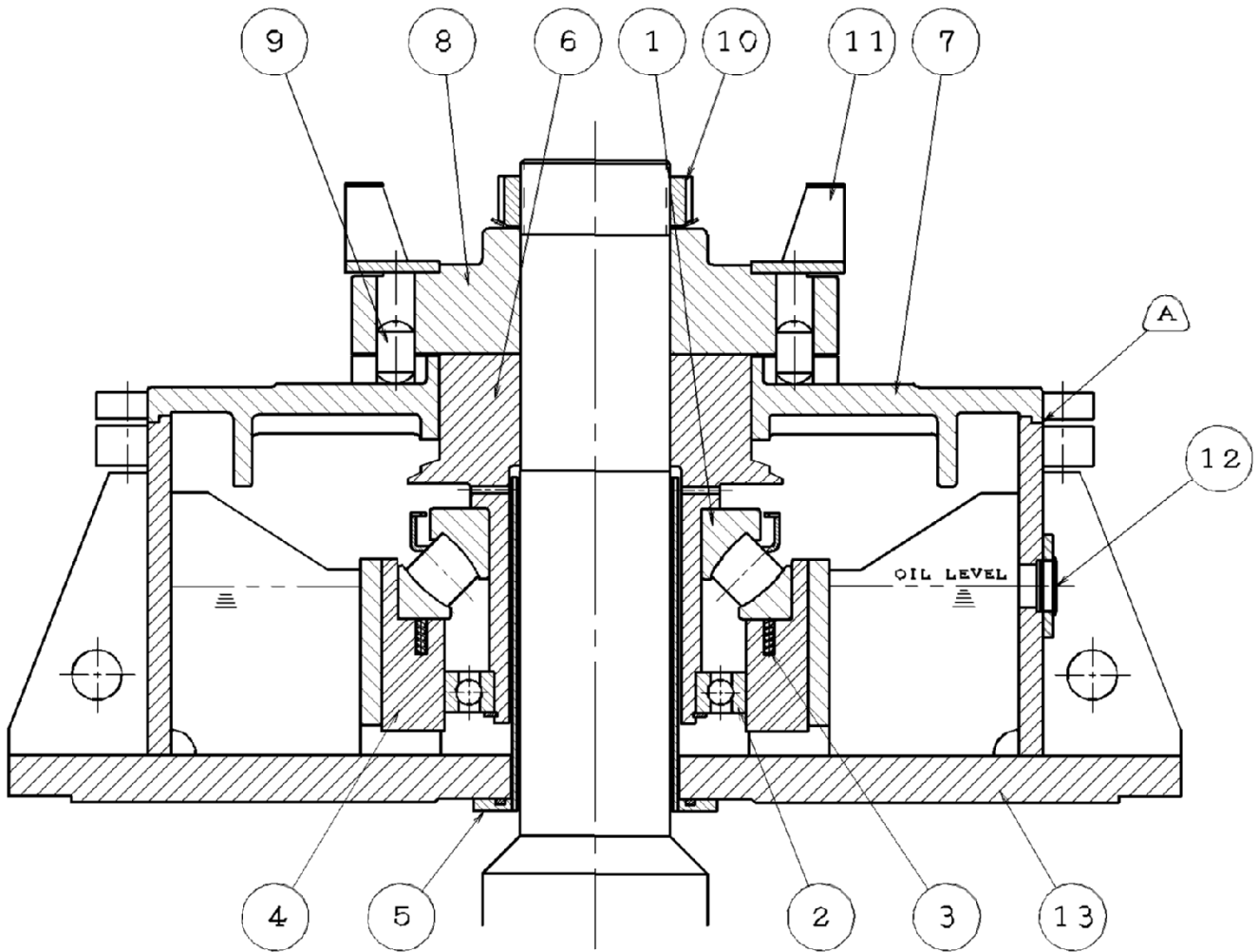

Item	Name	Item	Name
1	Thrust Bearing	8	Ratchet Pin Carrier
2	Ball Bearing	9	Ratchet Pin
3	Spring	10	Lock Nut
4	Insulation Bushing	11	External Fan
5	Oil Standpipe	12	Oil Lever Gauge
6	Upper Bearing Runner	13	Upper Bracket
7	Non-Reverse Ratchet		

Please be noted :

Use sealing compound on spigot of oil tank (A), between non-reverse ratchet (item 7) and upper bracket (item 13).

## Appendix 11. Sleeve bearing construction

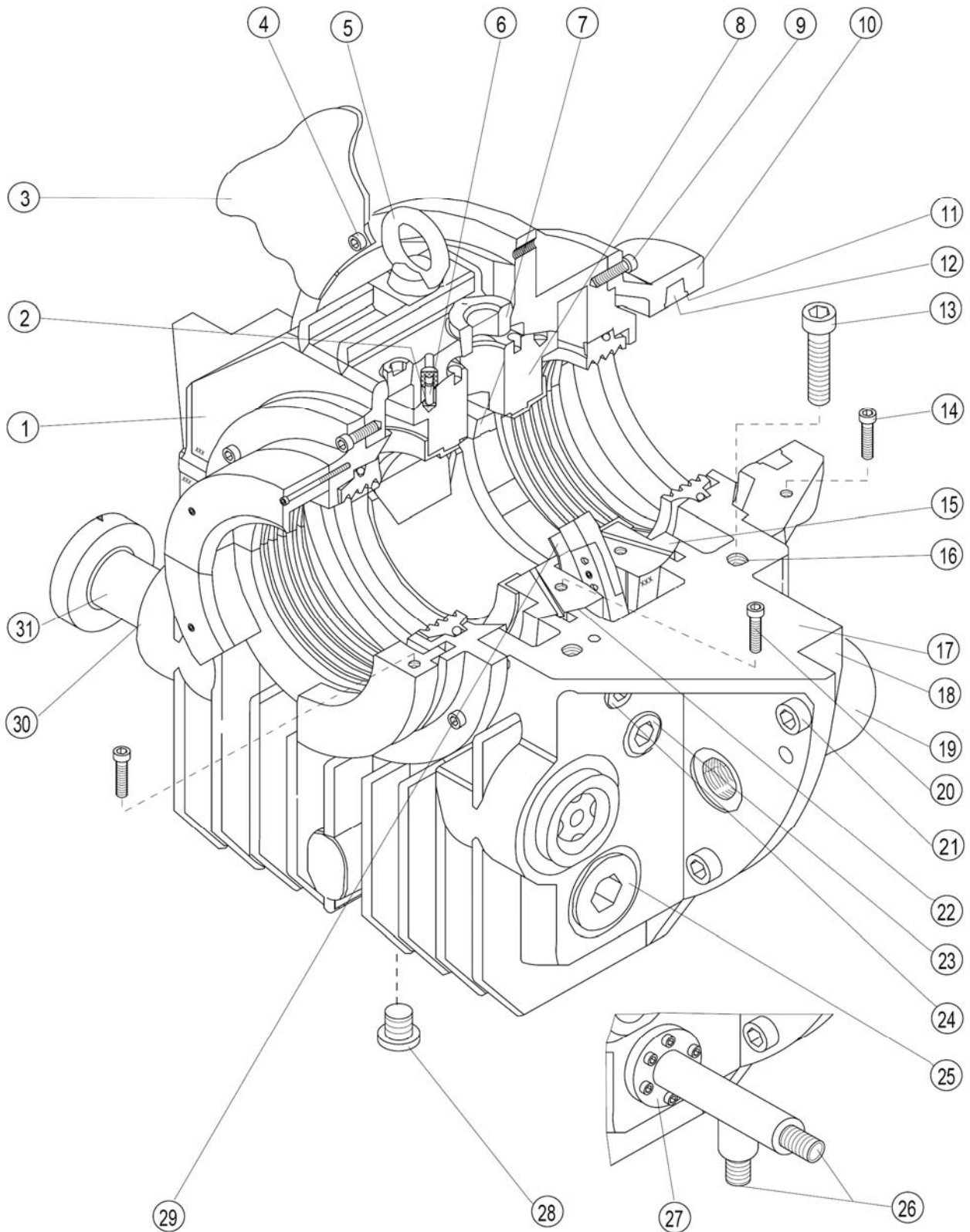

<b>Item</b>	<b>Name</b>	<b>Item</b>	<b>Name</b>
<b>1</b>	<b>Top half of the housing</b>	<b>2</b>	<b>Positioning pin nut</b>
<b>3</b>	<b>Plate ( Assembly opening )</b>	<b>4</b>	<b>Screw</b>
<b>5</b>	<b>Eye bolt</b>	<b>6</b>	<b>Positioning pin</b>
<b>7</b>	<b>Top sight glass</b>	<b>8</b>	<b>Top half of the shell</b>
<b>9</b>	<b>Screw</b>	<b>10</b>	<b>Machine seal</b>
<b>11</b>	<b>Hemp packing seal groove</b>	<b>12</b>	<b>Hemp packing</b>
<b>13</b>	<b>Screw(split line of the housing)</b>		
<b>14</b>	<b>Screw (split line of the machine seal)</b>		
<b>15</b>	<b>Bottom half of the shell</b>	<b>16</b>	<b>Tapped hole</b>
<b>17</b>	<b>Bottom half of the housing</b>	<b>18</b>	<b>Recess</b>
<b>19</b>	<b>Pressure equalizing hose</b>	<b>20</b>	<b>Screw (split line of the shell)</b>
<b>21</b>	<b>Screw</b>	<b>22</b>	<b>Spherical seating</b>
<b>23</b>	<b>Tapped hole for temperature measurement of the journal part</b>		
<b>24</b>	<b>Oil inlet connection hole</b>		
<b>25</b>	<b>Tapped hole for the oil sump temperature measurement</b>		
<b>26</b>	<b>Outlet/Inlet cooling water (optional)</b>		
<b>27</b>	<b>Cooler (optional)</b>		
<b>28</b>	<b>Hexagon head plug (Oil drain plug)</b>		
<b>29</b>	<b>Metal tabs ( optional for EMZL. )</b>		
<b>30</b>	<b>Oil outlet connection hole</b>		
<b>31</b>	<b>Oil outlet pipe</b>		

---

## Appendix 12. Mounting of Insulated Sleeve Bearings

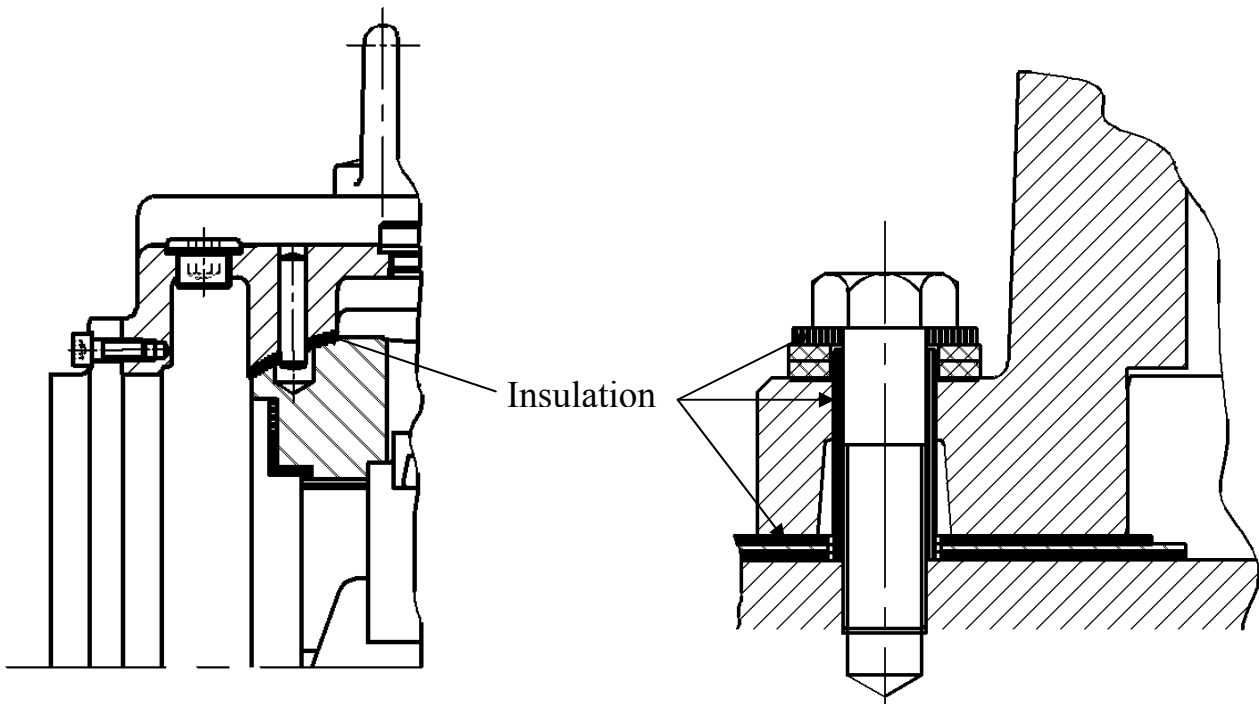

Please be noted :

Generally, a pedestal bearing is insulated by means of insulating washers or insulating bushes. (Right hand side of drawing)

Upon request insulated E bearings can be supplied. In this case the spherical seating which accommodates the bearing shell is covered with a non-conductive plastic foil. (Left hand side of drawing)

---

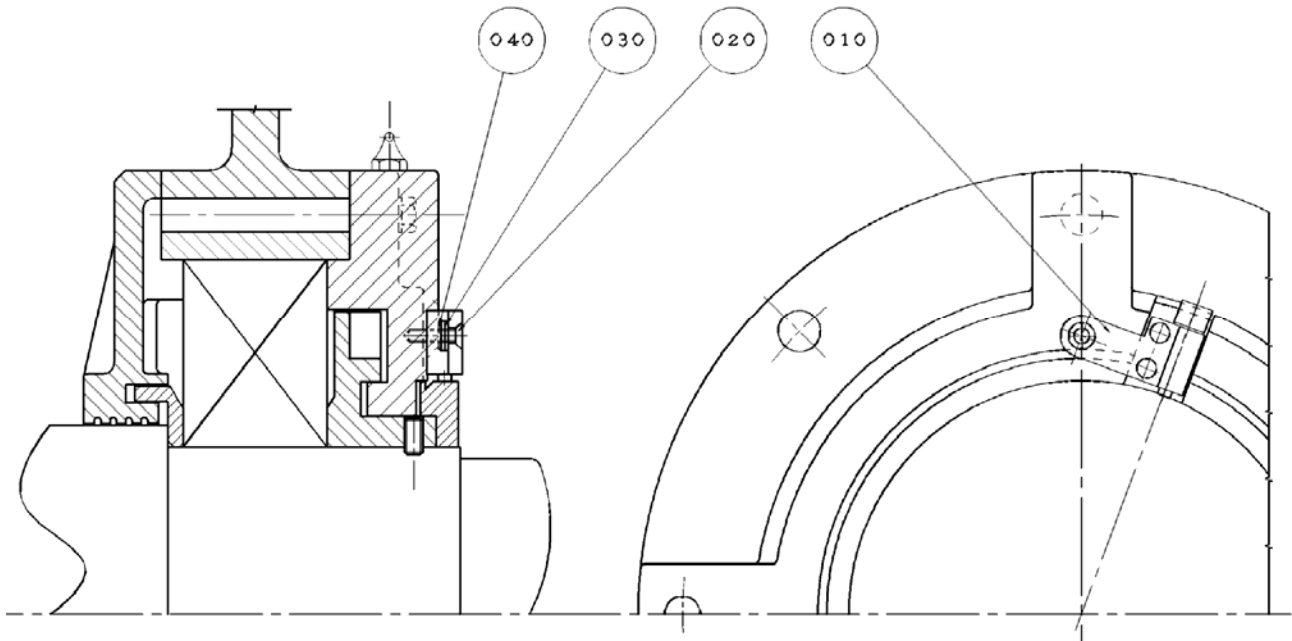
**Appendix 13. Shaft earth brush assembly drawing (Type I)**

<b>Item</b>	<b>Name</b>	<b>Item</b>	<b>Name</b>
<b>010</b>	<b>Brush</b>	<b>030</b>	<b>Plain Washer</b>
<b>020</b>	<b>CR C SCREW</b>	<b>040</b>	<b>T Lock Washer</b>

## Appendix 14. Shaft earth brush assembly drawing (Type II)

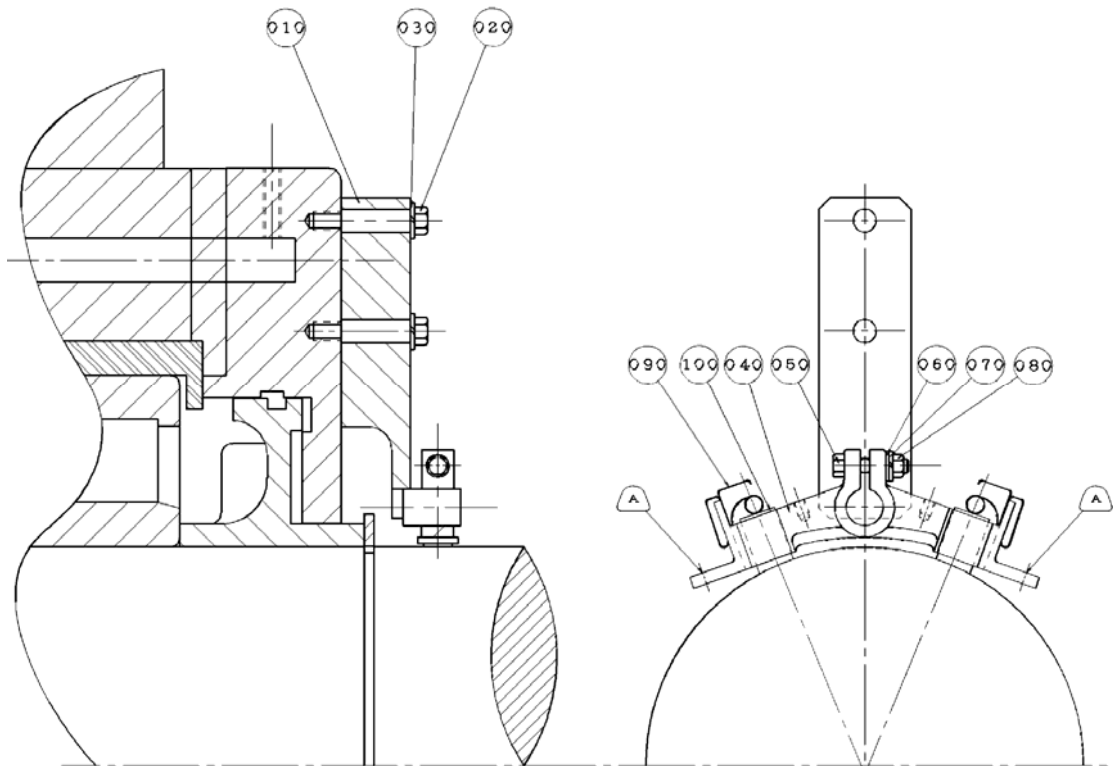

Item	Name	Item	Name
010	Support	060	Plain Washer
020	Hex Bolt	070	S Washer
030	S Washer	080	Hex Nut
040	Brush Holder	090	Brush Spring Assembly
050	Hex Bolt	100	Brush

Please be noted :

Directly connect grounding by a separate wire between one of M6 tap holes (A) on brush holder (item 040) and earth is highly recommended.

**Appendix 15. Bolt Torque (kg-cm)**

BOLD SIZE	THREAD PITCH	MILD STEEL (property class 4.6 or 4.8)		BRASS
		WITHOUT SPRING WASHER	WITH SPRING WASHER	WITHOUT SPRING WASHER
M4	0.7	25~34	10~13	8.4~11.3
M5	0.8	38~52	20~25	16.2~22.0
M6	1.0	68~97	40~50	28~38
M8	1.25	161~230	90~110	68~91
M10	1.5	288~416	180~230	125~183
M12	1.75	462~660	320~400	230~310
M16	2.0	1010~1440	800~1000	560~760
M20	2.5	2100~3000	1600~2000	1090~1470
M24	3.0	3800~5400	2800~3500	1870~2500
M30	3.5	8000~11500	5800~7250	3800~5100
M36	4.0	14000~20000	10000~12500	6500~8800

---

## Appendix 16. TECO Worldwide Operations

### HEAD OFFICE

Teco Electric & Machinery Co. Ltd  
 10F. No. 3-1 Yuan Cyu St.  
 Nan-Kang, Taipei 115  
 Taiwan R.O.C.  
 Tel: +886 2 6615 9111  
 Fax: +886 2 6615 2253  
[www.tecomotor.com.tw](http://www.tecomotor.com.tw)

### UNITED STATES

Teco-Westinghouse Motor Company  
 PO Box 227 (78680-0277),  
 5100 N.IH35 Round Rock Texas 78681 USA  
 Tel: +1 512 255 4141  
 +1 800 873 8326  
[www.tecowestinghouse.com](http://www.tecowestinghouse.com)

### CANADA

Teco-Westinghouse Motors Inc. (Canada)  
 18060-109th Ave  
 Edmonton, Alberta T5S 2K2 Canada  
 Tel: +1 780 444 8933  
 Fax: (780) 486-4575  
 24 HR Emergency Pager: (780) 419-7734  
 Toll Free: 800-661-4023  
 Fax Toll Free: 888-USE-TWMI  
[www.twmi.com](http://www.twmi.com)

### MEXICO

TECO-Westinghouse Motor Company, S.A. de  
 C.V.  
 CIRCUITO MEXIAMORA PONIENTE 321  
 PARQUE SANTA FE GUANAJUATO  
 PUERTO INTERIOR  
 SILAO, GUANAJUATO CP 36275, Mexico  
 E-mail: [ventas@tecowestinghouse.com](mailto:ventas@tecowestinghouse.com)  
 Tel: +52 (472) 748 9016 al 20

### CHINA

Suzhou Teco Electric & Machinery Co., Ltd  
 No. 1 Changjiang W.Rd.South-Dam  
 Industrial Park Liuhe Zhen, Taicang City,  
 Suzhou  
 Jiangsu Province, PRC  
 Tel: +86 512 5361 9901  
 Fax: +86 512 5396 1058

Wuxi Teco Electric & Machinery Co., Ltd.  
 No. 9 South Of Changjiang Road, New Zone,  
 Wuxi  
 Jiangsu Province. PRC  
 Tel: + 86 510 8534 2005  
 Fax: +86 510 8534 2001  
[www.wuxiteco.com](http://www.wuxiteco.com)

Jiangxi Teco Electric & Machinery Co., Ltd.  
 1328 Jinggangshan Rd., Nanchang  
 Jiangxi, PRC  
 Tel:+86 791 641 3690  
 Fax:+86 791 641 4228

Shanghai Office: Rm 321 Building No.6  
 Lane 1279 Zhongshan W. Rd.  
 Shanghai P.R.C  
 Tel: +86 21 5116 8255  
 Fax: +86 21 6278 8761

### HONG KONG

Tecoson Industrial Development (HK) Co., Ltd.  
 Rm 3712 Hong Kong Plaza  
 186-191 Connaught Rd West, Hong Kong  
 Tel: +852 2858 3220

---

**SINGAPORE**

Teco Electric & Machinery (PTE) Ltd.  
18 Chin Bee Drive  
Singapore 619865  
Tel: +65 6 265 4622  
Fax: +65 6265 7354  
[www.teco.com.sg](http://www.teco.com.sg)

**JAPAN**

Sankyo Co., Ltd.  
26th fl. World Trading Center Bldg.  
2-4-1 Hamamatsucho Minato-ku  
Tokyo Japan 105-6126  
Tel: +81 3 3435 9729  
Fax: +81 3 3578 8381

**INDONESIA**

P.T. Teco Multiguna Elektro  
JL Bandengan Utara No. 83/1-2-3  
Jakarta Utara-14400 Indonesia  
Tel: +62 21 662 2201  
Fax: +62 21 6697029

**MALAYSIA**

STE Marketing Sdn Bhd.  
Plo 52, Jalan Firma 2/1 Kawasan Perind.  
Tebrau 1, 81100 Johor Bahru Johor Malaysia  
Tel: +60 7 351 8862  
Fax: +607 354 6107

**THAILAND**

Teco Electric & Machinery (Thai) Co. Ltd.  
128/1 Soi Watsrivarenoi  
Moo 7 Bangna-Trad Road Km 18  
Bangchalong Bangplee  
Samuthprakarn 10540 Thailand  
Tel: +662 3371630-1

**VIETNAM**

TECO(Vietnam)Electric & Machinery Co., Ltd.  
KCN LONG Thanh, Huyen Long Thanh, Tinh  
Dong Nai.  
Tel: 84-061-3514108  
Fax: 84-061-3514410

---

---

**AUSTRALIA**

Sydney Office  
Teco Australia Pty Ltd.  
335-337 Woodpark Road  
Smithfield NSW 2164 Australia  
Tel: +61 2 9765 8118  
[www.teco.com.au](http://www.teco.com.au)

Melbourne Office  
Teco Australia Pty Ltd.  
16 Longstaff Road  
Bayswater VIC 3153 Australia  
Tel: +61 3 9720 4411

Brisbane Office  
Teco Australia Pty. Ltd.  
50 Murdoch Circuit,  
Acacia Ridge QLD 4110 Australia  
Tel: +61 7 3373 9600

Perth Office  
Teco Australia Pty Ltd.  
28 Belgravia Street,  
Belmont WA 6104 Australia  
Tel : +61 8 9479 4879

**NEW ZEALAND**

Teco New Zealand Pty Ltd.  
Unit 3 / 477 Great South Road  
Penrose Auckland New Zealand  
Tel: +64 9 526 8480

**MIDDLE EAST**

Teco Middle East Electric & Machinery Co.,  
Ltd.  
Kingdom of Saudi Arabia Dammam City  
P.O. Box 708 - Dammam 31421  
Tel: +966 3 835 2619  
Fax: +966 3 834 1678  
[www.teco-me.com](http://www.teco-me.com)

**NETHERLANDS**

Teco Electvic & Machinery B.V.  
Teco's European Head Office  
Rivium 3e Straat 27  
2909 LH Capelle a/d IJssel  
Netherlands  
Tel: +31 10 266 6633  
Fax: +31 10 202 6415

**UNITED KINGDOM**

Teco Electric Europe Limited  
7 Dakota Avenue, Salford. M50 2PU England  
Tel: +44 161 877 8025  
Fax: +44 161 877 8030  
[www.teco.co.uk](http://www.teco.co.uk)

**GERMANY**

Teco Electvic & Machinery B.V.  
Niederlassung Deutschland  
Marktstrasse 69  
37441 Bad Sachsa Germany  
Tel: +49 5523 95340  
Fax: +49 5523 953424  
[www.teco-westinghouse.de](http://www.teco-westinghouse.de)

**SPAIN**

Teco Electric & Machinery B.V.  
Spain Office  
C/Apostol Santiago, 38, 1º-1  
28017 Madrid, Spain  
Tel: +34 91 326 3091  
Fax: +34 91 326 3091

---

**TECO Worldwide Operations - Agents****KOREA**

Seorim Corporation  
#915, Woolim Lion's Valley I,  
311-3, Sangdaewon- dong,  
Jungwon-gu, Seongnam-city,  
Gyeonggi-do, Korea  
Tel: 82-31-737-2311  
Fax: 82-31-737-2312  
[www.seorimcorp.co.kr](http://www.seorimcorp.co.kr)

**PHILIPPINES**

Trade One  
No. 56 Aragon Street San Francisco  
Del Monte 1170 Quezon City Metro Manila,  
Philippines  
Tel:(632) 371-3032  
Fax:(632) 371-1175  
[www.tradeoneinc.com](http://www.tradeoneinc.com)

**TAIAN.(SUBIC)**

Phase I, Subic Bay Industrial Park Argonaut  
Highway Corner Brave Heart St., Subic Bay  
Freeport Zone Philippines 2222.  
Tel: 63-47-252-1668  
Fax: 63-47-252-3234  
[www.taian.com.ph](http://www.taian.com.ph)

**SOUTH AFRICA**

ArmCoil Afrika (Pty) Ltd.  
Unit 3 Prestige Park 127 Main Reef Road  
Technikon Roodepoort  
PO Box 500 Maraisburg 1700  
Gauteng South Africa  
Tel:+2711 763 2351  
Fax:+086 502 0086  
[www.armcoil.co.za](http://www.armcoil.co.za)

**TUNISIA**

AFRICA COMPANY  
RUE ENNASRIA, IMM. NAFOURA BLOC  
A-2-1 SFAX EL JADIDA 3027 SFAX -  
TUNISIE (TUNISIA)  
Tel: +216 74 40 28 85  
Fax: +216 74 4028 84

**SAUDI ARABIA**

Al-Quraishi Electrical Services of Saudi Arabia  
P.O.Box 7386-Dammam 31462  
Kingdom of Saudi Arabia  
Phone : +966-3-857-2537  
Fax : +966-3-857-2541  
[www.agesa.com](http://www.agesa.com)

**EGYPT**

Automation Management Solutions  
38 Mossadak Street, Dokki, Giza, Egypt  
Tel:+202 333 79 774  
Fax:+202 376 20 307

**JORDAN**

Sham Project's Solutions  
P.O. Box 2001  
Amman 11821-Jordan  
Tel: 962-6-5526-227  
Fax: 962-6-5526-228



For more information, please contact your local agent  
or branch office of TECO-Westinghouse.

**3A057D874E REV.04**

2010. Dec.

11W0-AA-C-57-874

---