

Totally Enclosed Fan-Cooled Type, Squirrel-Cage Rotor.

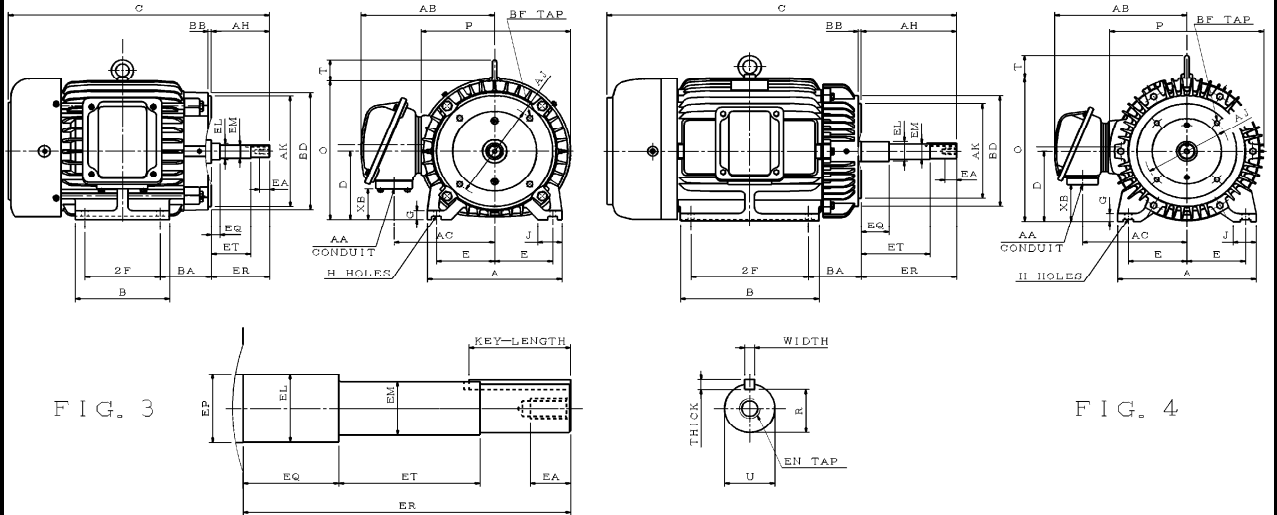

Dimension in inches

Output (HP)			FRAME SIZE	FIG. NO.	A	B	C	D	E	2F	G	H	J	O	P	T	AH	AJ	AK	BA	BB	BD	BF
2P	4P	6P																					
7.5	7.5	3	213JP	3	9.85	6.90	23.255	5.25	4.25	5.50	0.70	0.41	1.75	10.63	11.10	1.65	8.125	7.25	8.5	3.75	0.25	8.98	4-1/2"13UNC
10	10	5	215JP	3	9.85	8.35	24.745	5.25	4.25	7.00	0.70	0.41	1.75	10.63	11.10	1.65	8.125	7.25	8.5	3.75	0.25	8.98	4-1/2"13UNC
15	15	7.5	254JP	4	11.82	9.85	28.155	6.25	5.00	8.25	0.66	0.53	1.97	13.15	13.15	1.65	8.125	7.25	8.5	4.50	0.25	9.92	4-1/2"13UNC
20	20	10	256JP	4	11.82	11.81	29.905	6.25	5.00	10.00	0.66	0.53	1.97	13.15	13.15	1.65	8.125	7.25	8.5	4.50	0.25	9.92	4-1/2"13UNC

FRAME SIZE	KEY			KEYSEAT R	TERMINAL HOUSING				SHAFT EXTENSION								BEARINGS		APPROX. WEIGHT LBS	
	WIDTH	THICK	LENGTH		AA	AB	AC	XB	EA	EL	EM	EN	EP	EQ	ER	ET	U	DRIVE END		OPPOSITE DRIVE END
213JP	0.25	0.25	2.53	1.112	1"	9.78	7.34	2.34	1	1.75	1.375	1/2"-13UNC	1.763	2.375	8.125	5.875	1.25	6309ZZ	6306ZZ	186
215JP	0.25	0.25	2.53	1.112	1"	9.78	7.34	2.34	1	1.75	1.375	1/2"-13UNC	1.763	2.375	8.125	5.875	1.25	6309ZZ	6306ZZ	213
254JP	0.25	0.25	2.52	1.112	1 1/4"	11.3	8.86	3.22	1	1.75	1.375	1/2"-13UNC	1.763	2.375	8.125	5.875	1.25	6309ZZ	6307ZZ	325
256JP	0.25	0.25	2.52	1.112	1 1/4"	11.3	8.86	3.22	1	1.75	1.375	1/2"-13UNC	1.763	2.375	8.125	5.875	1.25	6309ZZ	6307ZZ	354

Note :

1. Dimension AK tolerance : +0.000 inches, -0.003 inches.
2. Dimension EL tolerance : +0.000 inches, -0.002 inches.
3. Dimension EM tolerance : +0.000 inches, -0.0005 inches.
4. Dimension U tolerance : -0.0005 inches, -0.001 inches.
5. Dimension D tolerance : +0.00 inches, -0.03 inches.
6. Dimension AH tolerance : +0.031 inches, -0.031 inches.
7. Dimension BB tolerance : +0.062 inches, -0.000 inches.
8. Dimension EQ tolerance : +0.015 inches, -0.015 inches.
9. Dimension ET tolerance : +0.015 inches, -0.015 inches.

ISSUED 20-May-10	PERFORMANCE DATA 3-PHASE SQUIRREL CAGE HIGH EFFICIENCY INDUCTION MOTORS	MODEL AEHH8N-JP
REVISED		PAGE 3 of 14



TEFC, NEMA T-FRAME, DESIGN - B or C,
CLASS F, 40°C AMBIENT, CONTINUOUS DUTY,
S.F. 1.15 460V 60Hz

TYPICAL PERFORMANCE (460V)

HP	FULL LOAD RPM	FRAME SIZE	EFFICIENCY(%)				POWER FACTOR(%)			CURRENT		TORQUE				ROTOR Wk ² lb-ft ²	NEMA CODE LETTER
			FULL LOAD		3/4 LOAD	1/2 LOAD	FULL LOAD	3/4 LOAD	1/2 LOAD	FULL LOAD (A)	LOCKED ROTOR (A)	FULL LOAD lb-ft	LOCKED ROTOR %FLT	PULL UP %FLT	BREAK DOWN %FLT		
			NOM.	MIN.	NOM.	NOM.	NOM.	NOM.	NOM.	NOM.	NOM.	NOM.	NOM.	NOM.	NOM.		
1	3465	143JP	82.5	80.0	81.5	78.5	85.0	79.5	68.5	1.34	15	1.515	350	365	400	0.046	N
	1745	143JP	85.5	82.5	84.0	81.5	73.0	64.5	51.5	1.50	15	3.009	310	280	410	0.086	N
	1150	145JP	82.5	80.0	82.5	80.0	65.5	57.0	44.5	1.73	15	4.566	250	220	300	0.122	N
1.5	3465	143JP	84.0	81.5	84.0	81.5	83.5	77.0	65.0	2.00	20	2.273	340	280	350	0.052	M
	1730	145JP	86.5	84.0	86.5	85.5	78.0	70.0	57.0	2.08	20	4.552	300	260	360	0.093	M
	1170	182JP	87.5	85.5	85.5	82.5	63.5	55.0	42.5	2.53	20	6.731	210	190	350	0.313	M
2	3465	145JP	86.5	84.0	86.5	85.5	86.0	80.5	70.0	2.52	25	3.031	350	315	390	0.064	L
	1740	145JP	86.5	84.0	84.0	84.0	78.0	70.0	57.0	2.78	25	6.035	270	220	330	0.108	L
	1170	184JP	88.5	86.5	88.5	86.5	70.5	63.0	50.5	3.00	25	8.975	180	150	270	0.423	L
3	3490	182JP	88.5	86.5	90.2	89.5	90.0	87.0	79.5	3.53	32	4.513	280	250	380	0.190	K
	1755	182JP	89.5	87.5	89.5	87.5	84.0	79.5	68.5	3.74	32	8.975	225	175	345	0.404	K
	1175	213JP	89.5	87.5	89.5	87.5	78.0	70.5	58.5	4.02	32	13.41	210	180	340	0.918	K
5	3480	184JP	88.5	86.5	89.5	89.5	92.5	91.0	85.5	5.72	46	7.544	290	230	320	0.272	J
	1745	184JP	89.5	87.5	88.5	88.5	85.5	81.5	71.5	6.12	46	15.04	185	140	285	0.422	J
	1170	215JP	91.0	89.5	91.0	89.5	82.5	77.0	65.5	6.24	46	22.44	190	160	300	1.224	J
7.5	3510	213JP	91.0	89.5	91.0	90.2	89.0	87.0	80.0	8.67	64	11.22	200	175	275	0.448	H
	1755	213JP	91.7	90.2	91.0	89.5	86.5	82.0	72.0	8.85	64	22.44	250	155	270	0.848	H
	1170	254JP	91.0	89.5	91.0	89.5	80.5	75.0	64.0	9.59	64	33.66	240	215	270	2.158	H
10	3510	215JP	91.0	89.5	91.7	91.0	89.5	88.5	82.5	11.5	81	14.96	220	180	260	0.573	H
	1755	215JP	91.7	90.2	91.0	89.5	86.0	84.0	75.5	11.0	81	29.92	250	145	260	1.062	H
	1170	256JP	91.0	89.5	91.7	90.2	80.5	75.0	64.0	12.8	81	44.87	225	185	250	2.872	H
15	3525	254JP	92.4	91.0	92.4	91.7	91.5	90.5	86.0	16.6	116	22.34	210	180	270	1.088	G
	1765	254JP	92.4	91.0	93.0	92.4	88.0	85.0	77.0	17.3	116	44.62	245	180	270	2.179	G
	1175	284JP	92.4	91.0	93.0	93.0	83.5	79.5	70.5	18.2	116	67.03	215	180	230	6.823	G
20	3520	256JP	92.4	91.0	93.0	93.6	92.5	91.5	88.0	21.9	145	29.83	210	180	260	1.407	G
	1760	256JP	93.0	91.7	92.4	92.4	87.5	84.5	78.5	23.0	145	59.66	200	145	240	2.871	G
	1170	286JP	91.7	90.2	92.4	92.4	84.0	81.0	73.0	24.3	145	89.75	210	160	225	8.340	G
25	3545	284JP	92.4	91.0	93.0	92.4	91.0	90.5	86.5	27.8	183	37.03	175	135	250	2.507	G
	1765	284JP	93.6	92.4	93.6	93.6	86.0	83.0	77.0	29.1	183	74.37	205	165	240	4.586	G
	1170	324JP	93.0	91.7	93.6	93.6	83.0	80.0	71.5	30.3	183	112.2	200	155	205	11.877	G
30	3545	286JP	93.0	91.7	93.6	93.0	91.0	90.5	87.5	33.2	218	44.43	175	140	240	2.831	G
	1770	286JP	93.6	92.4	93.6	93.6	87.5	85.5	79.5	34.3	218	88.99	200	160	235	5.274	G
	1175	326JP	93.0	91.7	93.6	93.6	80.5	78.5	71.0	37.5	218	134.1	210	180	230	12.372	G
40	3550	324JP	94.1	93.0	94.5	94.1	90.0	89.0	84.5	44.2	290	59.16	150	130	240	3.590	G
	1770	324JP	94.1	93.0	94.5	94.5	86.0	84.5	78.5	46.3	290	118.7	205	170	220	8.624	G
	1180	364JP	94.1	93.0	94.5	94.1	86.5	84.5	78.0	46.0	290	178.0	200	150	220	17.937	G
50	3550	326JP	94.1	93.0	94.5	94.5	91.0	90.0	86.5	54.7	363	73.95	150	130	240	4.488	G
	1770	326JP	94.5	93.6	95.0	95.0	87.0	86.0	80.5	56.9	363	148.3	210	170	220	10.124	G
	1180	365JP	94.1	93.0	94.5	93.6	86.0	83.0	75.5	57.8	363	222.5	225	170	240	21.386	G
60	3550	364JP	94.1	93.0	94.5	94.1	93.0	92.0	88.5	64.2	435	88.74	145	130	240	7.379	G
	1775	364JP	95.0	94.1	95.0	94.5	86.5	83.0	75.5	68.4	435	177.5	200	155	240	12.229	G
75	3555	365JP	94.5	93.6	95.0	95.0	93.0	92.5	89.0	79.9	543	110.8	145	130	250	9.056	G
	1775	365JP	95.4	94.5	95.4	95.0	86.5	83.5	75.5	85.1	543	221.8	200	165	250	14.674	G

- NOTE :
- The above are typical values based on test according to ANSI / IEEE standard 112 method B.
 - Breakdown & locked rotor torques are shown as average expected values.
 - Efficiency, power factor, speed and torque are the same for other voltages. Current values vary inversely with voltage.
 - Tolerance According to NEMA MG1-12 & IEC 60034-1.
 - Data subject to change without notice.

APPD.	M.C.Tsai	20-May-10	TECO Electric & Mac	DWG NO.
CHKD.	C.L.Huang	27-Apr-10		31057D98622
DWN.	AMO	15-Apr-10		

DATE:
Dec. 7, 2016

CONNECTION DIAGRAM

CATALOG NO.:
JPP0104

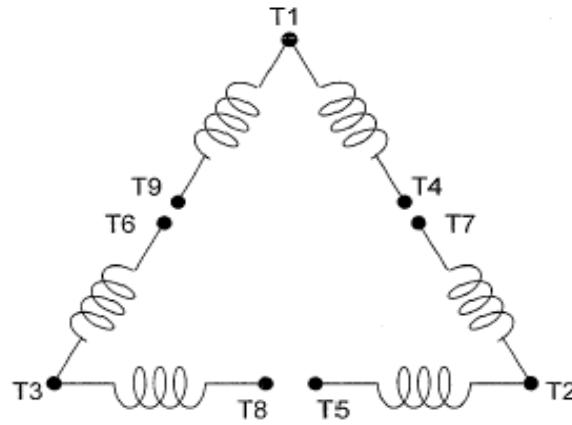

SCHEMATIC - 2Δ / Δ CONNECTION

ACROSS THE LINE CONNECTION

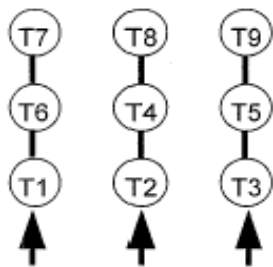

**LINE
230 VOLT CONNECTION**

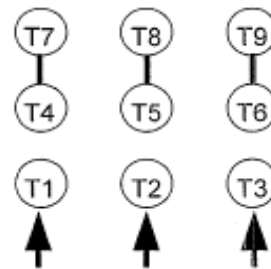

**LINE
460 VOLT CONNECTION**



INSTALLATION AND MAINTENANCE INSTRUCTIONS FOR THREE PHASE INDUCTION MOTORS

Frames 56 and 143T - 449TZ



5100 North IH 35 Round Rock, Texas 78681

RECEIVING

1. Check nameplate data.
2. Check whether any damage has occurred during transportation.
3. After removal of shaft clamp, turn shaft by hand to check that it turns freely.
4. If motor is to be reshipped (alone or installed to another piece of equipment) the shaft must again be clamped to prevent axial movement.

Note: Remove the bearing clamp before turning the shaft on 284T-449TZ frame motors.

WARNING

THE FOLLOWING SAFETY PRECAUTIONS MUST BE OBSERVED:

1. Electric rotating machinery and high voltage can cause serious or fatal injury if improperly installed, operated or maintained. Responsible personnel should be familiarized with NEMA MG-1; Safety Standards for Construction and Guide Selection. Installation and Use of Electric Motors and Generators; National Electric Code and all local safety requirements.
2. When servicing, all power sources to the motor and to the accessory devices should be de-energized and disconnected and all rotating parts should be at standstill.
3. Lifting means, when supplied, are intended for lifting the motor only. When two lifting devices are supplied with the motor a dual chain must be used.
4. Suitable protection must be used when working near machinery with high noise levels.
5. Safeguard or protective devices must not be by-passed or rendered inoperative.
6. The frame of this machine must be grounded in accordance with the National Electric Code and applicable local codes.
7. A suitable enclosure should be provided to prevent access to the motor by other than authorized personnel. Extra caution should be observed around motors that are automatically or have automatic re-setting relays as they may restart unexpectedly.
8. Shaft key must be fully captive or removed before motor is started.
9. Provide proper safeguards for personnel against possible failure of motor-mounted brake, particularly on applications involving overhauling loads.
10. Explosion proof motors are constructed to comply with the label service procedure manual, repair of these motors must be made by TECO-Westinghouse Motor Company or U/L listed service center in order to maintain U/L listing.

LOCATION

1. Drip-proof motors are intended for use where atmosphere is relatively clean, dry, well ventilated and non-corrosive.
2. Totally enclosed motors may be installed where dirt, moisture, or dust are present and in outdoor locations.
3. Explosion-proof motors are built for use in hazardous locations as indicated by Underwriters' label on the motor.
4. Chemical duty enclosed motors are designed for installation in high corrosion or excessive moisture locations.

Note: in all cases, no surrounding structure should obstruct normal flow or ventilating air through or over the motor.

MOUNTING

1. Mount motor securely on a firm, flat base. All ball bearing normal thrust motors up to and including 256T frame size may be side-wall or ceiling mounted; all others check nearest TECO-Westinghouse office for mounting recommendations.
2. Align motor accurately, using a flexible coupling if possible. For drive recommendations, consult with drive or equipment manufacturer, or TECO-Westinghouse.
3. Mounting bolts must be carefully tightened to prevent changes in alignment and possible damage to the equipment. The recommended tightening torque's for medium carbon steel bolts, identified by three radial lines at 120 degrees on the head, are:

Bolt Size	Recommended Torque (Ft-lb.)	
	Minimum	Maximum
2/8	25	37
1/2	60	90
5/8	120	180
3/4	210	320

4. V-belts Sheave Pitch Diameters should not be less than those shown in Table 1 (NEMA recommended values)
5. Tighten belts only enough to prevent slippage. Belt speed should not exceed 5000 ft. per min.

TABLE 1. V-Belt Sheave Pitch Diameters (MG1-14.42)

Frame Number					V-Belt Sheave			
					Conventional A, B, C, D AND E		Narrow 3V, 5V, AND 8V	
	Horsepower at				Minimum Pitch Diameter Inches	*Maximum Width Inches	Minimum Outside Diameter Inches	**Maximum Width Inches
	Synchronous Speed, RPM							
3600	1800	1200	900					
143T	1.5	1	.75	.5	2.2	4.25	2.2	2.25
145T	2-3	1.5-2	1	.75	2.4	4.25	2.4	2.25
182T	3	3	1.5	1	2.4	5.25	2.4	2.75
182T	5	2.6	5.25	2.4	2.75
184T	2	1.5	2.4	5.25	2.4	2.75
184T	5	2.6	5.25	2.4	2.75
184T	7.5	5	3.0	5.25	3.0	2.75
213T	7.5-10	7.5	3	2	3.0	6.5	3.0	3.375
215T	10	...	5	3	3.0	6.5	3.0	3.375
215T	15	10	3.8	6.5	3.8	3.375
254T	15	...	7.5	5	3.8	7.75	3.8	4
254T	20	15	4.4	7.75	4.4	4
256T	20-25	...	10	7.5	4.4	7.75	4.4	4
256T	...	20	4.6	7.75	4.4	4
284T	15	10	4.6	9	4.4	4.625
284T	...	25	5.0	9	4.4	4.625
286T	...	30	20	15	5.4	9	5.2	4.625

TABLE 1. V-Belt Sheave Pitch Diameters (MG1-14.42)

Frame Number					V-Belt Sheave			
					Conventional A, B, C, D AND E		Narrow 3V, 5V, AND 8V	
	Horsepower at				Minimum Pitch Diameter Inches	*Maximum Width Inches	Minimum Outside Diameter Inches	**Maximum Width Inches
	Synchronous Speed, RPM							
3600	1800	1200	900					
324T	...	40	25	20	6.0	10.25	6.0	5.25
326T	...	50	30	25	6.8	10.25	6.8	5.25
364T	40	30	6.8	11.5	6.8	5
364T	...	60	7.4	11.5	7.4	5.785
365T	50	40	8.2	11.5	8.2	5.785
365T	...	75	9.0	11.5	8.6	5.785
404T	60	...	9.0	14.25	8.0	7.25
404T	50	9.0	14.25	8.4	7.25
404T	...	100	10.0	14.25	8.6	7.25
405T	75	60	10.0	14.25	10.0	7.25
405T	...	100	10.0	14.25	8.6	7.25
405T	...	125	11.5	14.25	10.5	7.25
444T	100	...	11.0	16.75	10.0	8.5
444T	75	10.5	16.75	9.5	8.5
444T	...	125	11.0	16.75	9.5	8.5
444T	...	150	16.75	10.5	8.5
445T	125	...	12.5	16.75	12.0	8.5
445T	100	12.5	16.75	12.0	8.5
445T	...	150	16.75	10.5	8.5

*Max. Sheave width = $2(N-W) - .25$

**Max Sheave width = $N-W$

***Sheave ratios greater than 5:1 and center-to-center distance less than the diameter of the large sheave should be referred to TECO-Westinghouse.

POWER SUPPLY & CONNECTIONS

1. Wiring of motor and control, overload protection and grounding should be in accordance with National Electrical Code and all local safety requirements.
2. Nameplate voltage and frequency should agree with power supply. Motor will operate satisfactorily on line voltage within $\pm 10\%$ of nameplate voltage; or frequency with $\pm 5\%$ and with a combined variation not to exceed $\pm 10\%$. 230-volt motors can be used on 208-volt network systems, but with slightly modified performance characteristics as shown on the nameplate.
3. Dual voltage and single voltage motors can be connected for the desired voltage by following connection diagram shown on the nameplate or inside of the conduit box.
4. All Explosion Proof motors have Temperature Limiting Devices in the motor enclosure to prevent excessive external surface temperature of the motor in accordance with U/L standards. Terminals of thermal protectors (P1 & P2) should be connected to the motor control equipment, according to the connection diagram inside of the conduit box.
5. Standard connection diagram for three phase, not thermally protected, dual rotation motors are shown in diagrams A through E. **(Note: To change rotation, Interchange any two line leads)**

A. 3 Lead, Single Voltage



B. 6 Lead, Dual Voltage & Voltage Ratio 1 to 3

B-1 Across the Line Start & Run



B-2 Wye Start & Delta Run (Low Voltage only)



C. 9 Leads; Dual Voltage & Voltage Ratio 1 to 2, Wye Connected

C-1 Across the Line Start & Run



C-2 Part Winding Start (Low Voltage only)



D. 9 Leads; Dual Voltage & Voltage Ration 1 to 2, Delta Connected

D-1 Across the Line Start & Run



D-2 Part Winding Start (Low Voltage only)



E. 12 Leads, Dual Voltage

E-1 Across the Line Start & Run



E-2-1 Wye Start & Delta Run (Low Voltage only)



E-2-2 Wye Start & Delta Run (High Voltage only)



E-3 Part Winding Start (Low Voltage only)



*Important: For Part Winding Start, M2 contactor should be closed within two (2) seconds after M1 contactor is closed.
Only 4 pole and above (e.g., 6P, 8P...) motors are satisfactory for Part Winding Start at low voltage.

START UP

1. Disconnect load and start motor. Check direction of rotation. If rotation must be changed, ALLOW THE MOTOR TO STOP COMPLETELY. Interchange any two leads of a three-phase motor.
2. Connect load. The motor should start quickly and run smoothly. If no, shut power off at once. Recheck the assembly including all connections before restarting.
3. If excessive vibration is noted, check for loose mounting bolts too flexible motor support structure or transmitted vibration from adjacent machinery. Periodic vibration checks should be made; foundations often settle.
4. Operate under load for short period of time and check operating current against nameplate.

TESTING

If the motor has been in storage for an extensive period or has been subjected to adverse moisture conditions, it is best to check the insulation resistance of the stator winding with a megohmmeter. Depending on the length and conditions of storage it may be necessary to regrease or change rusted bearings.

If the resistance is lower than one megohm the windings should be dried in one of the following two ways:

1. Bake in oven at temperatures not exceeding 194°F until insulation resistance becomes constant.
2. With rotor locked, apply low voltage and gradually increase the current through windings until temperature measured with a thermometer reaches 194°F. Do not exceed this temperature.

MAINTENANCE

INSPECTION

Inspect motor at regular intervals. Keep motor clean and ventilation openings clear.

LUBRICATION

1. Frame 143T-256T: Double shielded and pre-lubricated ball-bearing motors without grease fittings and don't need re-lubrication, except on MAX-E1[®] and MAX-E2[®] products which have re-greasable features.
2. Frames 280TS, 320-449TZ(TS): Motors having grease fittings and grease discharge devices at brackets. Motors are shipped with grease for initial running. It is necessary to re-lubricate anti-friction bearing motors periodically, depending on size and type of service. See Table 2 to provide maximum bearing life. Excessive or too frequent lubrication may damage the motor.

TABLE 2

Horsepower	Standard Conditions	Severe Conditions	Extreme Conditions
1 Thru 30 Hp, 1800 rpm and below	7 years	3 years	180 days
40 Thru 75 Hp, 1800 rpm and below	210 days	70 days	30 days
100 Thru 150 Hp, 1800 rpm and below	90 days	30 days	15 days
1 Thru 20 Hp, 3600 rpm	5 years	2 years	90 days
25 Thru 75 Hp, 3600 rpm	180 days	60 days	30 days
100 Thru 150 Hp, 3600 rpm	90 days	30 days	15 days

Note:

- A. Standard conditions: 8 hours operation per day, normal or light loading, clear and 40°C ambient conditions.
 - B. Severe conditions: 24-hour operation per day or light shock loading, vibration or in dirty or dusty conditions.
 - C. Extreme conditions: With heavy shock loading or vibration or dusty conditions.
 - D. For double shielded bearings, above data (lubrication frequency) means that the bearing must be replaced.
3. Be sure fittings are clean and free from dirt. Using a low-pressure grease gun, pump in the recommended grease until new grease appears at grease discharge hole.
 4. Use the POLYUREA grease unless special grease is specified on the nameplate.
 5. If re-lubrication is to be performed with the motor running, stay clear of rotating parts. After re-greasing, allow the motor to run for ten to thirty minutes.

RENEWAL PARTS

1. Use only genuine TECO-Westinghouse renewal parts or as recommended by TECO-Westinghouse Motor Company.
2. When you order renewal parts please specify complete information to TECO-Westinghouse office/agent such as type, frame no., poles, horsepower, voltage, series no., quantity, etc.

**FOR FURTHER INFORMATION PLEASE CONTACT
TECO-WESTINGHOUSE MOTOR COMPANY**

Round Rock, TX

800-873-8326