

6

5

4

3

2

1

TYPE	OUTPUT		POLE	TIME RATING	VOLTAGE V	Hz	SYN. SPEED R.P.M
	HP.	kW.					
AEEH-ED	200	149	6	CONT	460	60	1200

TOTALLY ENCLOSED FAN-COOLED VERTICAL SOLID SHAFT TYPE, SQUIRREL CAGE ROTOR

NOTE:

1. DIMENSIONS IN INCH
2. FRAME NO.449VP
3. F CLASS INSULATION, S.F.: 1.15
4. FOR DIRECT COUPLING.
5. BEARING SIZE:
UPPER BEARING: 7326B (UNINSULATED)
LOWER BEARING: 6318C3 (UNINSULATED)
6. LUBRICATION:
UPPER BEARING USE OIL.
OIL VISCOSITY: ISO VG68 [300SSU AT 100°F]
OIL QUANTITY: 1.8 GAL.
LOWER BEARING USE GREASE.(MOBIL POLYREX EM)
7. ROTATION: COUNTER-CLOCKWISE [VIEW FROM TOP].
8. WITH NON-REVERSE RATCHET MECHANISM.
9. APPROXIMATE WEIGHT: 2920
10. REED FREQUENCY: 35 HZ
11. DOWNTHRUST: 11,400 LBS (L10-8800HRS)

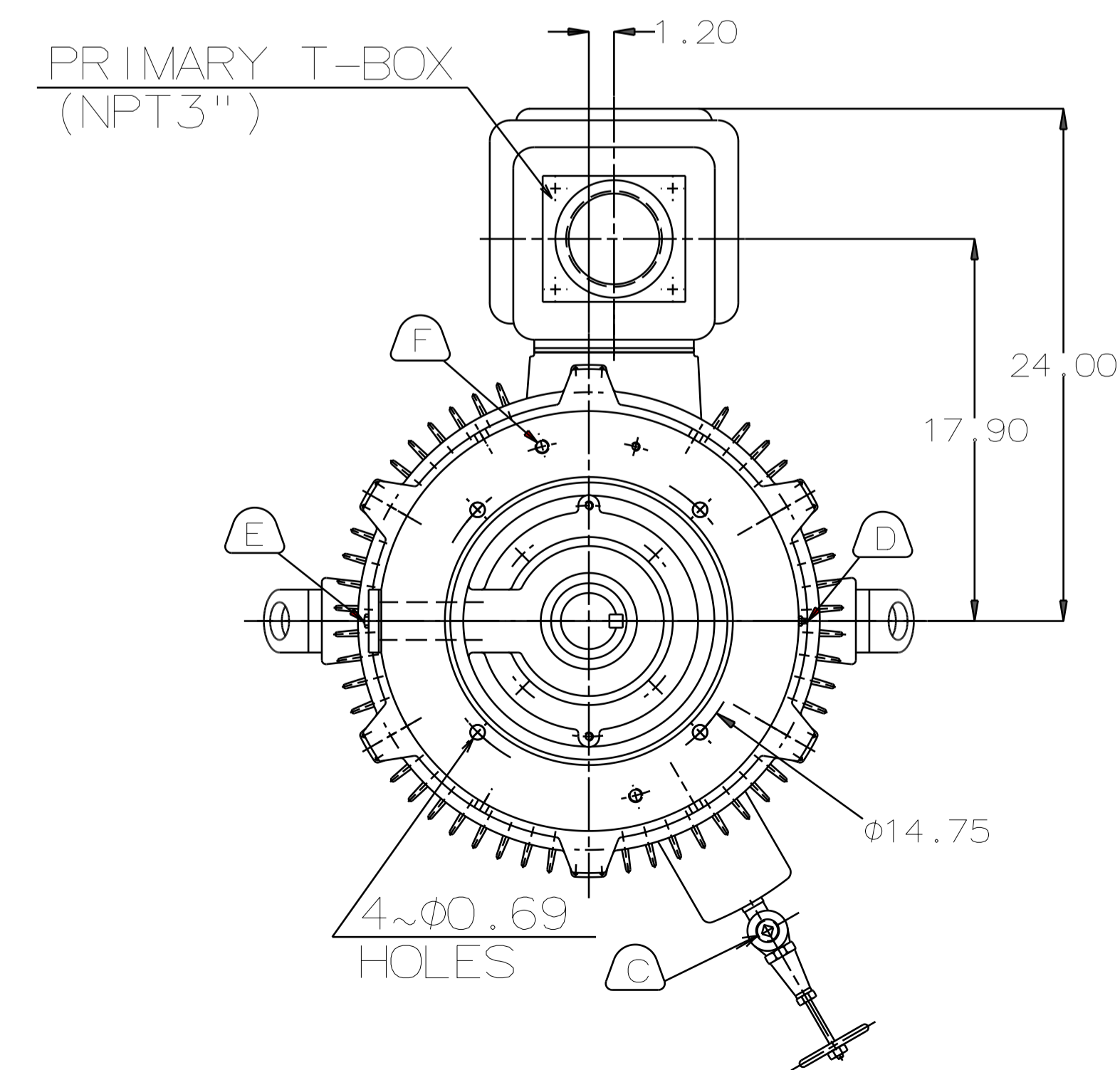
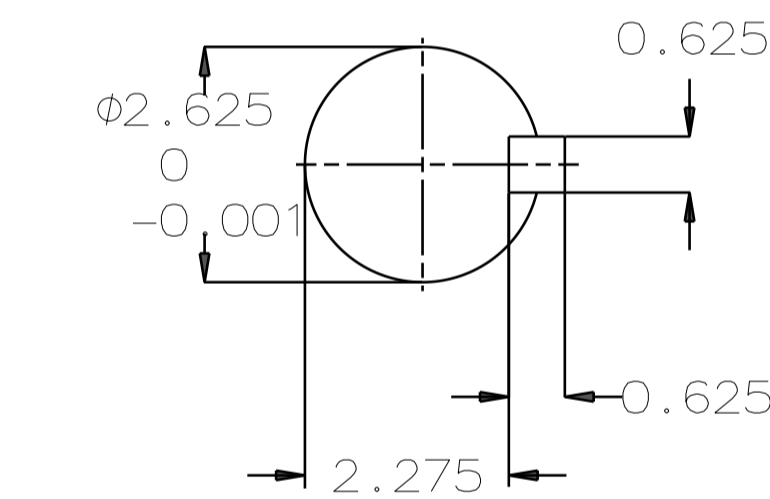
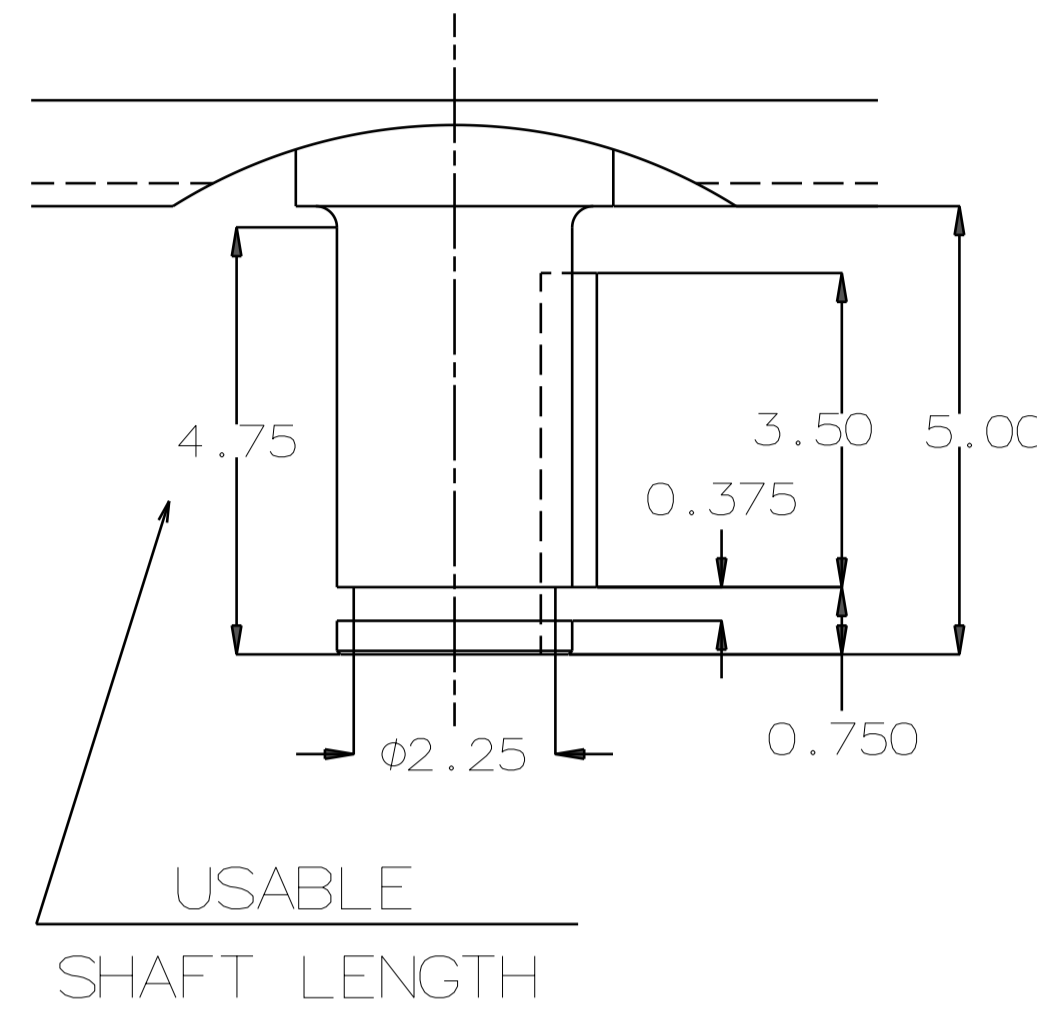
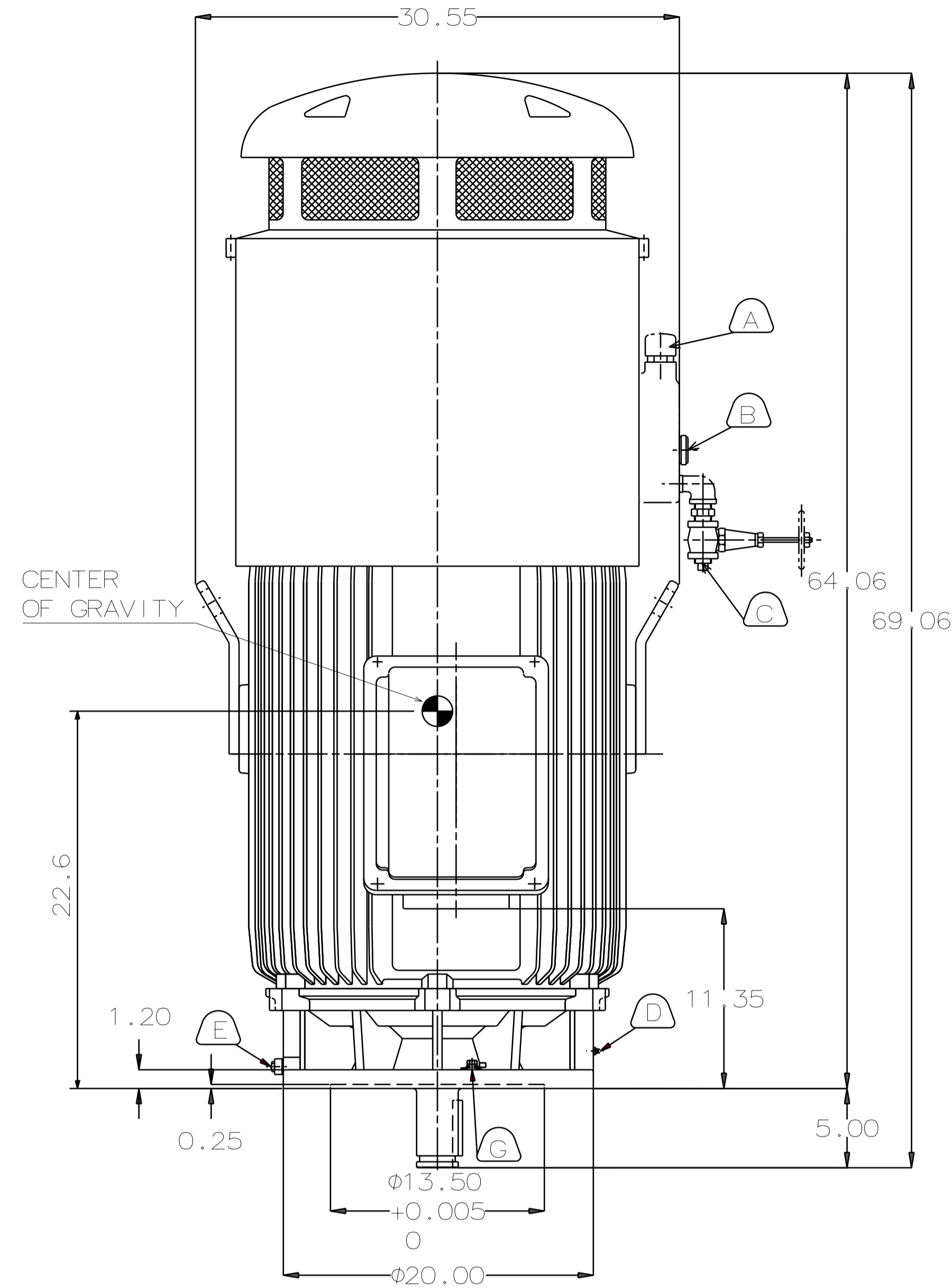

- A OIL FILLER [UPPER BEARING]
- B OIL GAUGE [UPPER BEARING]
- C OIL DRAIN [UPPER BEARING]
- D GREASE INLET [LOWER BEARING]
- E GREASE DISCHARGER [LOWER BEARING]
- F 2~M16 VERTICAL JACKING HOLES 180° APART IN MOTOR BASE.
- G M10 TAPPED HOLE IN MOTOR BASE WITH GROUNDING TERMINAL [R38-10] & BOLT LOCATED AS SHOWN.

DATE	DEC 08 2016	OUTLINE DIMENSIONS	
	VSTP2006	3-PHASE INDUCTION MOTOR	
DWN.	C.FU	APR.29.2015	DWG NO. REV:01
CHKD.	R.LEE	APR.29.2015	4B040L258
APPD.	C.LIU	APR.29.2015	



6

5

4

3

2

1

ISSUED APR. 30 2015	PERFORMANCE DATA HIGH THRUST HOLLOWSHAFT PUMP MOTORS LOW VOLTAGE SQUIRREL CAGE	MODEL AEEHED
REVISED		



TEFC, NEMA T-FRAME DESIGN B, CODE G, CLASS F, 40°C AMBIENT,
CONTINUOUS DUTY, 1.15 S.F. 230/460V 60HZ

ee C C 0 0 2 A

TYPICAL PERFORMANCE

(460V)

HP	FULL LOAD RPM	FRAME SIZE (EHV)	EFFICIENCY				POWER FACTOR			CURRENT		TORQUE			ROTOR WR ² lb-ft ²	DOWN THRUST LBS	APPROX. ROTOR WEIGHT LBS	APPROX. WEIGHT LBS	REED FREQ. Hz
			FULL LOAD %	3/4 LOAD	1/2 LOAD	FULL LOAD	3/4 LOAD	1/2 LOAD	FULL LOAD	LOCKED ROTOR	FULL LOAD	LOCKED ROTOR	BREAK- DOWN						
														NOM.					
			NOM.	MIN.	NOM.	NOM.	%	%	%	A	A	lb-ft	%FLT	%FLT					
100	1186	444VP	95.0	94.1	94.9	94.5	79.8	74.8	64.8	123	791	442.9	100	220	56.8	10000	550	1980	43
	890	447VP	94.5	93.6	94.4	94.0	76.0	71.0	61.0	130	791	590.2	100	220	119.6	12500	770	2450	44
125	1781	444VP	95.4	94.5	95.3	94.9	85.6	80.6	70.6	143	988	368.7	100	210	36.1	8800	460	1990	43
	1186	445VP	95.0	94.1	94.9	94.5	79.0	74.0	64.0	155	988	553.7	100	220	66.9	10000	610	2090	40
	889	447VP	95.0	94.1	94.9	94.5	76.2	71.2	61.2	161	988	738.6	100	220	140.4	12500	850	2640	42
150	1781	445VP	95.8	95.0	95.7	95.3	88.0	83.0	73.0	166	1186	442.4	100	210	47.9	8800	530	2050	40
	1188	447VP	95.8	95.0	95.7	95.3	77.2	72.2	62.2	189	1186	663.3	100	210	97.7	11400	720	2500	43
	890	449VP	95.0	94.1	94.9	94.5	76.6	71.6	61.6	192	1186	885.4	100	220	189.6	12500	1070	3060	35
200	1781	447VP	96.2	95.4	96.1	95.7	82.5	77.5	67.5	235	1581	589.9	100	200	62.2	10000	610	2480	44
	1188	449VP	95.8	95.0	95.7	95.3	76.6	71.6	61.6	254	1581	884.4	100	210	123.2	11400	850	2920	35
250	1783	449VP	96.2	95.4	96.1	95.7	83.1	78.1	68.1	292	1977	736.6	100	210	79.3	10000	730	2910	35
	1188	449VP	95.8	95.0	95.7	95.3	74.3	69.3	59.3	328	1977	1105.5	100	210	145.1	11400	940	3180	34
300	1783	449VP	96.2	95.4	96.1	95.7	83.1	78.1	68.1	351	2372	883.9	100	220	93.0	10000	790	3140	34

NOTE : 1. THE ABOVE ARE TYPICAL VALUES BASED ON TEST ACCORDING TO ANSI/IEEE STANDARD 112 METHOD B.

2. BREAKDOWN & LOCKED ROTOR TORQUES ARE SHOWN AS AVERAGE EXPECTED VALUES.

3. EFFICIENCY, POWER FACTOR, SPEED AND TORQUE ARE THE SAME FOR OTHER VOLTAGES. CURRENT VALUES VARY INVERSELY WITH VOLTAGE.

4. DECLARED EFFICIENCY HAVN'T TAKEN INTO ACCOUNT OF THRUST LOAD LOSSES

5. TOLERANCE ACCORDING TO NEMA MG1-12& IEC 34-1

6. THRUST LOAD LOSSES ESTIMATED OF ANGULAR CONTACT BALL BEARING AS FOLLOWS : (ACCORDING TO NEMA STANDARD MG1-12.7)

FRAME SIZE	LOSS HP /100 RPM	RPM/1000 LB THRUST
444VP~445VP		0.0180
447VP~449VP		0.0194

7. REDUCING THE THRUST LOAD WILL INCREASE BEARING LIFE AS FOLLOWS :

THRUST(%)	100	82	73	62	56	51
BEARING LIFE(Hrs.)	8800	15000	20000	30000	40000	50000

8. DATA SUBJECT TO CHANGE WITHOUT NOTICE

9. **ee** C C 0 0 2 A IS SUITABLE FOR 4, 6 POLE UP TO 200HP.

10. 230/460 V UP TO 125HP, 150HP AND ABOVE, APPLY 460/(800) V ONLY

APPD. M.Y.HSU	APR. 30 2015	TECO Electric & Machinery Co., Ltd.	DWG NO.
CHKD. H.Y.WANG	APR. 30 2015		3A057M071E
DWN. H.Y.WANG	APR. 30 2015		REV.00

TECO

CONNECTION DIAGRAM

MODEL

DATE :
DEC.04.'02

For Δ/Δ connection

DAC-1545-1

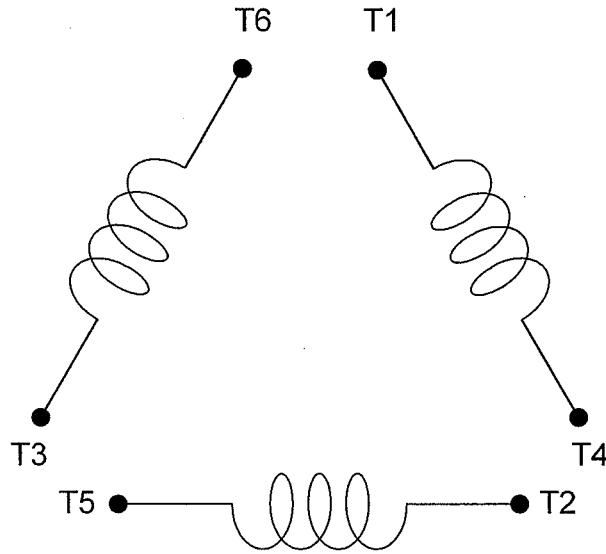

SCHEMATIC - Δ/Δ CONNECTION

ROTATION

(VIEWED FROM DRIVE END)



CONNECTION

$\Delta-\Delta$ START

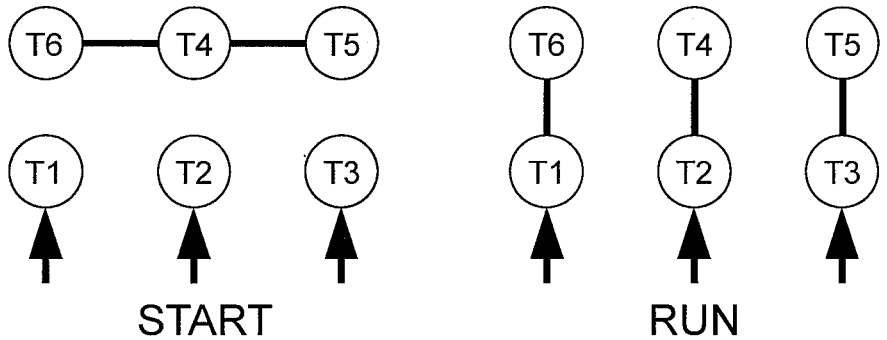

ACROSS-THE-LINE



承 認		
審 核	蔡	Dec.05.02
校 對	林	Dec.04.02
繪 製	林賢龍	DEC,04,'02

東元電機股份有限公司
TECO ELECTRIC & MACHINERY CO., LTD.
 TAIWAN R.O.C.

圖 號：
DAC-1545-1



**120 VOLT SINGLE PHASE POWER SOURCE
SHOULD BE DE-ENERGIZED WHEN MOTOR IS IN OPERATION**

Parallel

SPACE HEATER SCHEMATIC DIAGRAM



Instructions For Three Phase Induction Motors

**Vertical High Thrust Type
IEC Frame 112 (NEMA Frame 182) and above**



INDEX	Page
1. INTRODUCTION.....	3
1.1 General.....	3
1.2 Serial Number of the Machine	4
1.3 Mounting Position	4
1.4 Direction of Rotation	4
2. ACCEPTING, INSPECTION, STORAGE, TRANSPORTATION	5
2.1 Inspection Upon Receipt	5
2.2 Storage	5
2.3 Transportation	9
3. INSTALLATION.....	10
3.1 Site and Environment for Motor Installation.....	10
3.2 Foundation	11
3.3 Installation of Shaft Coupling	12
3.4 Electrical Connections.....	15
4. OPERATION.....	17
4.1 Examination Before Start.....	17
4.2 Starting Operation.....	21
5. MAINTENANCE	25
5.1 Major Points in Regular Inspection and Maintenance	25
5.2 Motor Windings	25
5.3 Clean the Interior of the Motor.....	26
5.4 Clean the Exterior of the Motor	27
5.5 Maintenance of Anti-friction Bearing	28
5.5.1 Frequency of Relubrication	28
5.5.2 Kinds of Grease	28
5.5.3 Grease Quantity	30
5.5.4 Re-Greasing.....	30
5.5.5 Oil Relubrication (For oil lubrication types only)	31
5.5.6 Cleaning and Installation of Bearings	32
5.6 Maintenance of Non-Reverse Ratchet Mechanism	32
5.7 Dismantling and Assembly Procedure	40
5.8 Records of Operation and Maintenance	42
6. FAULT FINDING AND RECOGNITION	37
7. RECYCLE.....	39
Appendix 1. Daily Inspection.....	42
Appendix 2. Monthly Inspection	43

Appendix 3. Regular Inspection	44
Appendix 4. Typical Motor Cross Sectional Drawings : SCIM, TEFC	47
Appendix 4-1. Typical Motor Cross Sectional Drawings : SCIM, TEFC	48
Appendix 4-2. Typical Motor Cross Sectional Drawings : SCIM, TEFC	49
Appendix 5. Typical Motor Cross Sectional Drawings : ODP	50
Appendix 5-2. Typical Motor Cross Sectional Drawings : ODP	52
Appendix 6. Typical Motor Cross Sectional Drawings : SCIM, TEWC.....	53
Appendix 7. Typical Ball Bearing Construction Drawing	54
Appendix 7-1. Typical Ball Bearing Construction Drawing	55
Appendix 8. Typical Roller Bearing Construction Drawing.....	56
Appendix 9. Typical Ball Bearing with Insulation Bushing Construction Drawing.....	57
Appendix 10. Typical Thrust Bearing Assembly Drawing (Vertical Machine).....	58
Appendix 11. Shaft Earth Brush Assembly Drawing (TAC)	59
Appendix 12. Shaft Earth Brush Assembly Drawing (TECO).....	60
Appendix 13. Bolt Torque (kg-cm)	61
Appendix 14. TECO Worldwide Operations	62

1. INTRODUCTION

1.1 General

TECO-Westinghouse high thrust vertical motors covered in this instruction manual are high quality materials and designed to give long and trouble free service when properly installed, maintained and operated in strict accordance with the outline drawing, motor nameplates and this instruction manual. These motors, including both hollow shaft and solid shaft, are generally used to drive pumps and must not be altered or modified in any unauthorized manner.

High voltage and rotating machinery could cause serious injury or loss of life. Installation, operation, and maintenance must be performed by qualified and competent personnel only.

Since this instruction manual cannot cover every eventuality of installation, operation and maintenance, the following points should however be considered and checked.

- Technical data and information on permissible use such as assembly, connection, ambient, area classification and operating conditions given in the related catalogue, operating instructions, nameplates and other production documentation.
- General assembly/installation and safety regulations
- Local (job site) and plant-specific specifications and requirements
- Proper use of transport, lifting devices and tools
- Use of personal protective equipment

The following safety indications should be observed when reading these instructions:



Electric Hazard.



Danger.

ATTENTION !

Warning of possible damage to the motor or installation.

This instruction manual is for **TECHNICAL USE ONLY, NOT FOR COMMERCIAL PURPOSE**. The warranty is limited to coverage expressed in your sales contract. Documentation of storage, transportation, installation and examination, if required, shall be obtained from TECO-Westinghouse service centers before start and maintenance.

1.2 Serial Number of the Machine

Each electric motor is identified with a serial number. Serial number is stamped on a main name plate which is attached to the frame by rivets.

1.3 Mounting Position

All vertical motors covered in this instruction manual, shall be arranged vertically as shown below during storage, transportation, handling and installation.



IM3011

Vertical flange mounting (VFM)

Fig. 1 Mounting Arrangement

1.4 Direction of Rotation

The arrow on the direction nameplate indicates the direction of the rotation, view from Non Drive End (or top). The motor must be operated in the direction shown.



Fig. 2 Direction nameplate

ATTENTION !

Operating the motor in the incorrect direction may cause serious damage to both the motor and driven equipment.

2. ACCEPTING, INSPECTION, STORAGE, TRANSPORTATION

2.1 Inspection Upon Receipt

Check the following upon receipt:

- Is there any visible damage to the motor or case? Any damage should be photographed, documented and reported to the carrier and TECO-Westinghouse immediately.
- Are the nameplate ratings identical with your confirmed order ?
- Are dimensions and color in compliance with your specifications ?
- Are the nameplate ratings for heater, thermal protector, temperature detector, etc. identical with your confirmed order ?
- Are all accessories and accompanying instruction manuals in good order ?
- Does the arrow head indicate the correct direction of rotation?
- If there are any specific requirements, please ensure they are in conformity with your specification.
- Motor stator housing may be outfitted with condensation drain holes that are either open holes, drain holes with plugs or drain holes with breather drains. For horizontally mounted motors position the drain holes at the lowest point possible to allow for the egress of condensation. For vertical shaft installations the lower end bracket must be outfitted with drains at the lowest point possible. Prior to installation remove drain plugs if fitted.

2.2 Storage

2.2.1 General

When motors are not in operation, the following precautionary measures must be taken to insure the motors do not suffer deterioration or damage from moisture, dust and dirt, or careless handling. The climate, length of time the equipment is to be stored, and the adequacy of the storage facilities will determine the storage precautions required.

Any deterioration or damage of the motors due to customer's incorrect storage of the motors is not covered by the warranty. This includes all periods of time when the motor is installed on site but has not been placed into operation.

The following procedures must be followed and a maintenance log must be kept to keep from voiding factory warranty. The records are also useful to decide if a motor is suitable or not to be put into service.

2.2.2 Location

The ideal storage area is a clean, heated, and well-ventilated building.

- (a) High and dry, well-ventilated indoor, without exposure to direct sun lights, free from dust, corrosive gas (such as chlorine, sulfur, dioxide, and nitrous oxides) and fumes, and infestation by vermin or insects.
 - (b) The ideal storage temperature range is from 10°C to 50°C (50°F to 125°F), and relative humidity is $\leq 60\%$.
 - (c) Not close to a boiler or freezer.
 - (d) Precautions should be taken to prevent rodents, snakes, birds or other small animals from nesting inside the motors. In area where they are prevalent, precautions must be taken to prevent insects, such as dauber wasps, from gaining access to the interior of motors.
-

- (e) Entirely free from vibration. Vibration levels above 3.8 mm/s (0.15 in/sec) velocity could damage the bearings and cause “false brinelling” of the bearing races.
- (f) Motors should be put on pallets to prevent moisture from accumulating underneath.
- (g) Motors should be stored in a heated building, outdoor storage is not suitable for motors.
- (h) If motors have to be stored outdoors for some reasons, they should be well covered with a tarpaulin and protected from contamination and moisture. The cover should extend to the ground however it should not tightly wrap the motor. This will allow the captive air space to breath, minimizing formation of condensation. Motors should be well shielded from dust, but under well-ventilated conditions. Outdoor storage should be for a very short period of time (less than one month) only and the risk of deterioration is the responsibility of the users.

2.2.3 Motor Position

Motors must be stored in vertical position. Where motors are mounted to machinery, the mounting must be such that drains and breathers are fully operable and are at the lowest point of the motor.

2.2.4 Moisture Prevention

Since moisture can be very detrimental to electrical components, the motor temperature should be maintained about 5°C above the dew point temperature by providing either external or internal heat. If the motor is equipped with space heaters, they should be energized at the voltage shown by the space heater nameplate attached to the motor. Check weekly that the space heaters are operating. Incandescent light bulbs can be placed within the motor to provide heat, if the anti-condensation space heaters are not fitted. However, if used, incandescent bulbs must not be allowed to come in contact with any parts of the motor because of the concentrated hot spot that could result.

2.2.5 Prevent Corrosion and Frost Damage

When motors are shipped from the factory, external machined surfaces, including the shaft extension and bearing journals on sleeve bearing motors, are covered with a protective coating. This coating should be examined periodically to make sure that it has not been accidentally removed. If necessary, re-coat the surfaces with a rust inhibiting material, such as Rust Veto No.342 or an equivalent. Care should be taken to keep parts such as fitted surface, key, shaft extension, mounting feet or face, and axial central hole from any collision with foreign matters, and to have rust preventative in place. It is a good practice to seal any shaft openings with silicone, rubber caulking, or tape. If any rust is observed, measures should be taken to remove the rust and protect against it. Grease or anti-corrosion agent should also be generously applied to prevent rusting.

ATTENTION !

Immediately remove any shrink wrap that may have been used during shipping. Never wrap any motor in plastic for storage. This can turn the motor into a moisture trap causing severe damage.

For water-cooled motors or motors using bearings with water-cooling coils, please make sure the water is dried off of the coils to prevent tube corrosion or frost damage.

TECO-Westinghouse reserves the right to void warranties based upon evidence of rust or other indications of moisture inside the motor that indicate that the motor was improperly stored.

2.2.6 Insulation Resistance Test

Even during storage, the insulation resistance should be kept above the specified values.

- (a) For measurement of insulation resistance and acceptable standard values, please refer to measures stated in 4.1.2 "Measurement of insulation resistance".
- (b) Insulation resistance test should be performed once every three months.
- (c) Resistance measurement of each temperature detector (ex. PT $100\Omega/^{\circ}\text{C}$) is necessary once every three months.

2.2.7 Long Period of Idle (storage)

If the motor is not in operation for a long period of time (one week and above) after installation or has been in operation but stopped for a period of time, the following precautions must be taken.

- (a) Protect the motor as stated in 2.2.4 and 2.2.5.
- (b) Insulation resistance test should be performed as stated in 2.2.6.
- (c) Bearing Protection per 2.2.8.
- (d) Operation test should be performed once every three (3) months.
- (e) If external vibration is present, the shaft coupling should be opened.
- (f) If motors are equipped with drain plugs, they should be removed.
- (g) When motors equipped with brushes, the brushes should be lifted in the brush holder, if there is no protective strip (such as MYLAR) between the brushes and collector rings.
- (h) For water-cooled motors or motors using bearings with water-cooled coils, ensure the water is dried off the coils to prevent tube corrosion or frost damage.
- (i) Storage maintenance must be documented for warranty and reference purposes.

2.2.8 Bearing Protection

- (a) If the motor has been provided with a shaft shipping brace to prevent shaft movement during transit, it must be removed before operating the motor. It is very important that this brace be reinstalled exactly as it was originally, before the motor is moved from storage or any time when the motor is being transported. This prevents axial rotor movement that might damage the bearings.



Fig. 3-1

Fig.3-2

Shaft Shipping Brace

- (b) Motors equipped with oil lubricated bearings are shipped from the factory with the bearing oil reservoirs drained. In storage, the oil reservoirs should be properly filled to the center of the oil level gauge with a good grade of rust inhibiting oil. To keep the bearing well oiled and prevent rusting, the motor shaft should be rotated several revolutions every month ensuring the shaft does not come to rest in its original position. If the motor is not in operation for over six months, dismantle the upper cover of the bearing housing and check the anti-corrosion protection.



Fig. 4 Upper and lower bearing



Motor must not be moved with oil in reservoir. Drain oil before moving to prevent sloshing and possible damage. Refill oil when motor has been moved to the new location.

- (c) Motors with anti-friction bearings are properly lubricated with the correct grade of grease at the factory and no further greasing is required in storage. If the motor is not in operation for over three months, add grease to each bearing per lubrication nameplate. The shaft should be rotated at least 15-20 revolutions every month to maintain proper distribution of the grease within the bearings.
- (d) If the storage is over two years, it is recommended that the bearing assembly be dismantled and that the bearing parts are inspected before commissioning. Any corrosion has to be removed with fine emery cloth.

2.2.9 Removal From Storage

After long period of idle or storage, and, prior to energizing the motor, a thorough inspection and megger test of windings is required. The bearings should be inspected for corrosion, false brinelling and deformation.

If any of the following conditions exist, then re-conditioning may be required before putting a motor into service.

- (a) Winding resistance is less than recommended.
- (b) Evidence of rust or other indications of moisture inside the motor.
- (c) Corrosion or false brinelling or deformation occurred in bearings.
- (d) Idle or storage longer than the warranty period.
- (e) Idle or storage in dirty or damp surroundings.
- (f) Storage in unheated area where the temperature and humidity fluctuate.
- (g) Idle or storage where it has been subject to vibration, such as from nearby machinery or passing traffic.
- (h) Outdoor storage.
- (i) No maintenance records showing that the storage procedures have been followed.

Any reconditioning required, as noted by the inspections after removal from storage, should be performed prior to putting the motor into service. Such inspection and testing or re-conditioning are available from local TECO-Westinghouse service/facilities. Reconditioning after idle or storage is not covered by factory warranty. Any parts that must be replaced due to damage or deterioration will be at customer's cost.

2.3 Transportation

ATTENTION !

To keep the rotating parts of motors from moving, thus preventing damage and scratching during transportation, they should be held securely with a locking device. Ensure all locking devices are removed before operating the motor. This device must be reinstalled, exactly as it was originally, before the motor is moved from storage or any time when the motor is being transported.

Vertical mount type motors should be transported in a safe stable and vertical position only.



Do not use the hoisting hook/eyebolts to lift more than the motor itself. They are designed to support the motor only.

Make sure the hoisting hook is correctly attached to the eyebolt(s) or lug(s) of the motor and that the eyebolt(s)/lug(s) are fully threaded in before hoisting. Also note such parts as fan cover, ventilation box, bracket, slip-ring covers, etc. may have their own hoisting lugs which can only carry their own weight. Nothing extra should be attached while hoisting.

Do not twist or cross the steel cables. Make sure the eyebolts have been securely threaded with the shoulder flush and the sling angle is correct.



Fig. 5

3. INSTALLATION

3.1 Site and Environment for Motor Installation

3.1.1 General

Standard environment and site conditions for the installation of motors are usually set as follows:

- (a) Ambient temperature: $-20 \sim +40$ °C
- (b) Humidity: Relative humidity shall be below 95%RH for totally-enclosed types, and below 80%RH for semi-enclosed types.
- (c) Elevation: Below 1000 meters.
- (d) Harmful gases, liquids, dusts and high moisture levels should be absent.
- (e) Foundations should be strong and free of vibration.

For water-cooled motors or motors using bearings with water-cooling coils, the ambient temperature must not drop below 5°C (41°F) to prevent frost damage. If lifting a motor under -20°C

is required, or there are any special environmental conditions, please inform us at time of order.

3.1.2 Ventilation and Space

- (a) Installation area should be well-ventilated.
- (b) The installation space should be large enough to facilitate heat dissipation and maintenance.

3.2 Foundation

Motor manufacturer is not responsible for the foundation design. Motor weight, thrust load, twisting moments, seismic forces and other external applied loads must be considered in foundation design by others.

3.2.1 Reactions of Vertical Motor

For a vertical motor with N pcs hold down bolts, the reactions necessary for foundation design are as follows – kgs per bolt at centerline of hold down bolt holes:

(a) Rated motor torque (T_R), reactions = $T_R / \text{bolt number} / (\text{PCD}/2)$

(b) Maximum motor torque (T_{\max}),

$$\text{Reactions} = T_{\max} / \text{bolt number} / \text{PCD}/2$$



Fig. 6

3.2.2 The foundation of vertical induction motor (Also the foundation of pump)

- (a) Foundation of motor/pump must be rigid and secure to provide adequate support. There must be no vibration, twisting, misalignment etc. due to inadequate foundations.
- (b) A massive concrete foundation is preferred in order to minimize vibration. Rigidity and stability are enhanced by prop plate and foundation bolt. As shown in Fig.7 and Fig.8.



Fig. 7



Fig. 8

3.2.3 Installation of vertical motor

- (a) All mounting surfaces must be clean and level.
- (b) Foundation must be leveled at least at 4 points and guaranteed to be below 0.04mm flat and level.
- (c) Make sure the mortar and concrete are completely dry, and the precision of the level is acceptable, then set the motor on the mounting foundation.
- (d) Accurately install shaft couplings.

3.3 Installation of Shaft Coupling

3.3.1 General

ATTENTION !

Motors must always be accurately aligned, and this applies especially where they are directly coupled.

Incorrect alignment can lead to bearing failure, vibration and even shaft fracture. As soon as bearing failure or vibration is detected, the alignment should be checked.

3.3.2 Mounting procedure

Field installation of a coupling to the motor shaft should follow the procedures recommended by the coupling manufacturer. The motor shaft extension must not be subjected to either extreme heat or cold during coupling installation.

3.3.3 Alignment

The motor shaft and the driven shaft should be aligned within the following tolerances in both angular and parallel alignment:

TIR	Range of rotating speed	Solid coupling	Flexible coupling
C	2500rpm and above	0.03	0.03
	Below 2500rpm	0.04	0.05
A	2500rpm and above	0.03	0.03
	Below 2500rpm	0.03	0.04

Unit : mm

Angular misalignment is the amount by which the centerlines of driver and driven shaft are skewed. It can be measured using a dial indicator set up as shown in Fig.9. The couplings are rotated together through 360 degrees so that the indicator does not measure run out of the coupling hub face. The shafts should be forced against either the in or out extreme of their end float while being rotated.

Parallel misalignment is the amount by which the centerlines of the driver and driven shafts are out of parallel. It can be measured using a dial indicator set up as shown in Fig.10. Again, the couplings are rotated together through 360 degrees so that the indicator does not measure runout of the coupling hub outside diameter.

TIR = Total indicator reading (by dial indicator)



Fig. 9



Fig. 10

ATTENTION !

Measurements should be made only after shimming and with hold-down bolts properly tightened.

3.3.4 Dowel for Motor

After the motor has been properly aligned with the driven equipment and the hold-down bolts have been installed and tightened, for motors with fabricated frame, at least two dowel pins should be installed in two diagonally opposite motor feet.

3.3.5 Installation of Shaft Coupling (Vertical Hollow Shaft Motor Only)

Bolted coupling as Fig.11

- Bearings are provided to absorb some upward shaft thrust when the coupling is fitted.
- The coupling is fastened with bolts.

(c) This coupling type is not auto-release type.

Note : Standard high thrust motors can absorb momentary up thrust load up to 30% of the standard down thrust load. If the up thrust is long duration (over 10 seconds) and/or exceeds 30% of the standard high thrust rating, special design arrangements are required and a standard motor is not suitable.



Fig. 11

3.3.6 Non-Reverse Ratchet/Coupling, as Fig. 11 (If fitted)

The non-reverse coupling is also a bolted type and,

- (a) It prevents the pump and motor from rotating in the reverse direction.
- (b) It also prevents damage from over speeding and damage to pump shaft and bearings.
- (c) The ratchet pins or balls are lifted by the ratchet teeth and are held clear by centrifugal force and friction as the motor comes up to speed.
- (d) When power is removed, speed decreases, and the pins or balls fall. At the instant of reversal, a pin or ball will catch in a ratchet tooth and prevent backward rotation.
- (e) When installing the non-reverse coupling, do not use lubricant. Lubrication will interfere with proper operation. The top half of the coupling should seat solidly on the lower half and the pins or balls should touch the bottom of the pockets between the teeth in the plate.
- (f) As with the bolted coupling, the up thrust capabilities are 30% of the standard high thrust rating for down thrust.

ATTENTION !

Do not apply non-reverse ratchets on applications in which the pump reversal time from shutdown (the instant the stop button is pressed) to zero speed is less than one second.

3.3.7 Manual Rotation of Large Vertical Rotor with Sleeve Bearing During Alignment

- (a) If there is a thread in the non-drive end shaft center, the breakaway torque can be overcome by the use of torque wrench provided there is no ratchet. Remove the top cover, insert a bolt in the threaded shaft center and use a torque wrench to apply the rotating force. The breakaway torque value will determine the size of torque wrench required.

$$\text{Torque [kg-mm]} = \text{Rotor Wt [kg]} * \text{Thrust Pad Center Radius [mm]} * 0.4$$

0.4 = coefficient of friction for dry lubrication

- (b) An alternate is to use a long bar bolted to the coupling to apply the torque.
- (c) If the rotor can be lifted either from above using a crane attached to the top of the rotor or from below using a jack, then the rotor weight is reduced and the torque needed to breakaway is much less. This does not always work, as sometimes the pads adhere to the thrust collar face due to cohesion.

There is no danger of Babbitt damage due to breakaway because it only takes a small revolution of the rotor to lubricate all shoe surfaces.

3.3.8 Removal of Redundant Shaft Key

When the length of coupling hub is different from the length of shaft key, the motor may have a high vibration level due to this unbalance condition. The removal of redundant shaft key is necessary, shown as Fig.12.

Method (1):

After installing the coupling, use a grinding wheel to remove the redundant key (hatch area).

Method (2):

Before installing the coupling, calculate the different length between coupling hub and shaft key, then cut the half of this different value (hatch area) to achieve approximate-balance condition.



Fig. 12

3.4 Electrical Connections

All interconnecting wiring for controls and grounding should be in strict accordance with local requirements such as the USA National Electrical Code and UK IEE wiring regulations.

Wiring of motor and control, overload protection and grounding should follow the instructions of connection diagrams where provided.

3.4.1 Power

The rated conditions of operation for the motor are as shown on the nameplate. Within the limits, given below, of voltage and frequency variation from the nameplate values, the motor will continue to operate but with performance characteristics that may differ from those at the rated conditions :

+/- 10% of rated voltage

+/- 5% of rated frequency

+/- 10% combined voltage and frequency variation so long as frequency variation is no more than +/- 5% of rated

ATTENTION !

Operating the motor at voltages and frequencies outside of the above limits can result in both unsatisfactory motor performance and damage to or failure of the motor.

3.4.2 Main Lead Box

The main lead box furnished with the motor has been sized to provide adequate space for the make-up of the connections between the motor lead cables and the incoming power cables.



The bolted joints between the motor lead and the power cables must be made and insulated in accordance with the best industry practices.

3.4.3 Grounding

Both fabricated steel motors and fan cooled cast frame motors are provided with grounding pads or bolts.



The motor must be grounded by a proper connection to the electrical grounding system.

3.4.4 Rotation Direction

The rotation direction of the motor will be as shown by a nameplate on the motor, specification table or the outline drawing. The required phase rotation of the incoming power for this motor rotation may also be stated. If either is unknown, the correct sequence can be determined by the following method.

Make sure the motor is uncoupled and the non-reverse ratchet (if installed) has been disabled according to 5.6.3., start the motor and observe the direction of rotation. Allow the motor to achieve full speed before disconnecting it from the power source. Refer to the operation section of this manual for information concerning initial start-up. If resulting rotation is incorrect, it can be reversed by interchanging any two (2) incoming cables.

3.4.5 Auxiliary Devices

Auxiliary devices such as resistance temperature detectors, thermocouples, thermoguards, etc., will generally terminate on terminal blocks located in the auxiliary terminal box on the motor. Other devices may terminate in their own enclosures elsewhere on the motor. Such information can be obtained by referring to the outline drawing. Information regarding terminal designation and the

connection of auxiliary devices can be obtained from auxiliary drawings or attached nameplates.

If the motor is provided with internal space heaters, the incoming voltage supplied to them must be exactly as shown by either a nameplate on the motor or the outline drawing for proper heater operation.

ATTENTION !

Caution must be exercised anytime contact is made with the incoming space heater circuit as space heater voltage is often automatically applied when the motor is shutdown.

4. OPERATION

4.1 Examination Before Start

4.1.1 Wiring Check

For proper motor installation, ensure the wiring diagram is followed and the points below are adhered to:

- (a) Make sure all wiring is correct.
- (b) Ensure the sizes of cable wires are appropriate and all connections are well made for the currents they will carry.
- (c) Ensure all connections are properly insulated for the voltage and temperature they will experience.
- (d) Ensure the capacity of fuse, switches, magnetic switches and thermo relays etc. are appropriate and the contactors are in good condition.
- (e) Make sure that frame and terminal box are grounded.
- (f) Make sure the starting method for the motor in question is followed correctly.
- (g) Make sure switches and starters are set at the correct positions.
- (h) Motor heaters must be switched off when the motor is running.

4.1.2 Measurement of Insulation Resistance



During and immediately after measuring, the terminals must not be touched as they may carry dangerous residual voltages. Furthermore, if power cables are connected make sure that the power supplies are clearly disconnected and there are no moving parts.

- (a) For rated voltage below 1000V, measure with a 500VDC megger.
For rated voltage above 1000V, measure with a 1000VDC megger.
- (b) In accordance with IEEE 43-2000, there are three recommendation minimum insulation resistance values. These values corrected to 40°C are :
 - (1) $kV+1$ in Megohms for most windings made before 1970, all field windings and windings not otherwise described.
 - (2) 100 Megohms for most DC armatures and AC windings built after about 1970 with form

wound coils.

- (3) 5 Megohms for machines with random wound stator coils and for form wound coils rated below 1kV.

ATTENTION !

After measurement the winding must be grounded or shunted to discharge residual voltages.

- (c) On a new winding, where the contaminant causing low insulation resistance is generally moisture, drying the winding through the proper application of heat will normally increase the insulation resistance to an acceptable level. The following are several accepted methods for applying heat to a winding :

- (1) If the motor is equipped with space heaters, they can be energized to heat the winding.
- (2) Direct current (as from a welding equipment) can be passed through the winding. The total current should not exceed approximately 20% of rated full load current. If the motor has only three leads, two must be connected together to form one circuit through the winding. In this case, one phase will carry the full applied current and each of the others, one-half each. If the motor has six leads (3 mains and 3 neutrals), the three phases should be connected into one series circuit.



Ensure there is adequate guarding so live parts cannot be touched.

- (3) Heated air can be either blown directly into the motor or into a temporary enclosure surrounding the motor. The source of heated air should preferably be electrical as opposed to fueled (such as kerosene) where a malfunction of the fuel burner could result in carbon entering the motor.

ATTENTION !

Caution must be exercised, when heating the motor with any source of heat other than self contained space heaters, to raise the winding temperature at a gradual rate to allow any entrapped moisture to vaporize and escape without rupturing the insulation. The entire heating cycle should extend over 15-20 hours.

Insulation resistance measurements can be made while the winding is being heated. However, they must be corrected to 40°C for evaluation since the actual insulation resistance will decrease with increasing temperature. As an approximation for a new winding, the insulation resistance will be approximately halved for each 10°C increase in insulation temperature above the dew point temperature.

- (d) Should the resistance fail to attain the specified value even after drying, careful examination should be undertaken to eliminate all other possible causes, if any.

4.1.3 Power Source

-
- (a) Ensure the capacity of the power source is sufficient.
 - (b) Ensure the supply voltage and frequency ratings are identical to those on the nameplate.
 - (c) Voltage variation should be confined to $\pm 10\%$ of the rated value and the phase to phase voltages should be balanced.

4.1.4 Bearing Lubrication

- (a) For oil lubricated bearing motors, the oil reservoir must be filled with oil to the correct level. On self-lubricated bearings, the standstill oil level will be at the center of the oil gauge. The proper oil is a rust and oxidation inhibiting, turbine grade oil. Refer to the lubrication nameplate for the recommended viscosity.
- (b) Motors which are supplied with provision for flood lubrication have an inlet regulator to meter the oil flow to the bearing. Refer to the outline drawing for this accessory. If the supply oil quantity does not match that stated on the outline, the oil regulator must be adjusted to the specified flow rate. In line with operation conditions (degree of contamination of the oil) filters must be cleaned according to the instructions of the manufacturer. The recommendation mesh size of the filters is 15~20 μ m.

Oil inlet temperature :

Normal	20°C (70°F) ~ 49°C (120°F)
Alarm	60°C (140°F)
Trip	65°C (150°F)

- (c) If the motor is in storage for over three (3) months, refilling of some new oil should be undertaken before operation to prevent bearing damage due to dry friction. The oil level should be kept at the center of the oil gauge. If necessary, drain some oil after refilling.
- (d) Grease lubricant type
 - (1) The bearings have been well greased at factory before delivery. However, regreasing is required if a significant period has elapsed between manufacture and use or in storage. Fill new grease until it overflows and the old grease is entirely replaced.
 - (2) Unless otherwise specified and shown on nameplate, ExxonMobil Polyrex EM is the standard applied to TECO-Westinghouse motors.
 - (3) If roller bearing is used, add a small amount of grease if abnormal sound occurs in the bearings. If this sound, disappears temporarily after regreasing, it is a normal condition and can operate as it is, as long as the temperature rise of the bearing is normal.

4.1.5 Cooling Water for the Cooler on Water-Cooled Motors

Make sure the quality, volume and inlet temperature of cooling water for the motors are normal before the machine is in operation.

Water : General tower water or industrial water, the suspended solid shall be below 20 μ m/l

Volume : Please see outline drawing

Inlet temperature : Normal below 30°C (86°F) ; above 5°C (41°F)

Alarm 35°C (95°F)

Trip 40°C (104°F)

Special temperature settings will be noted in outline drawings.

4.1.6 For Motors Equipped with Independent Force-Ventilating Blower Unit

- (a) Ensure the voltage and frequency of the power source are identical to the ratings shown on blower motor name plate.
- (b) Ensure the wiring to blower motor is according to the connection diagram.
- (c) Test run the blower motor to ensure the phase currents are within the tolerance limits.
- (d) Ensure the cooling air flow direction is correct. Refer to motor outline for cooling air flow direction.
- (e) Blower motor should be started prior to operating the main motor.
- (f) Do not switch off the blower motor immediately after the main motor is shut off. It must be left running for 15 minutes after the main motor is shut down.
- (g) For small blower motor, double shield and pre-lubricated ball bearings are used and re-lubrication is not necessary.

4.1.7 Remove All Locks

ATTENTION !

Make sure all locks which fasten the movable parts of the motor during transportation are dismantled and removed so the shaft can rotate freely.

4.1.8 Clean Before Starting

ATTENTION !

Ensure there are no foreign objects or tools inside the motor before starting.

4.1.9 Transmission System Check

Make sure the transmission system, including belts, screws, bolts, nuts and set pins are in good condition.



The keys fitted to the shaft extensions are held by plastic tape only to prevent them from falling out during transportation or handling. The shaft key shall be removed to prevent it from flying out when the motor is operated prior to the couplings being fitted to the shaft extension.

4.1.10 Test Run

Make sure the items above are examined. Test the motor running with or without load. Record and check according to the statement of 5.8 "Records of operation and maintenance" at 15 minute intervals during the first three hours of operation. Then regular examinations should take place at longer intervals. If everything goes well, the motor can be classified as "in good order".

ATTENTION !

To avoid the abnormal bearing temperature and vibration level increases, it is not recommended to run a vertical high thrust motor continuously without load.

4.2 Starting Operation

4.2.1 Starting Load

Initially run the motor unloaded prior to coupling to the driven machine. Unless otherwise specified, a motor usually starts with light load which is then gradually increased proportional to the square of speed and at last reaches 100% load at full load speed.

4.2.2 Starting

Too frequent starts can harm the motors. The following restrictions should be observed :

- (a) Motor can be restarted should the initial start fail. Two starts are generally permissible when the motor is cold.
- (b) Motor can be started only once when it is at normal running temperature.
- (c) Should additional starts be necessary beyond the conditions stated above, the following restrictions should be noted :
 - (1) Let the motor cool down for 60 minutes before restarting, fully loaded.
 - (2) Let the motor cool down for 30 minutes before restarting, unloaded.
 - (3) Two inching starts can be regarded as one normal start.

ATTENTION !

**If the motor rotor fails to start turning within one or two seconds, shut off the power supply immediately.
Investigate thoroughly and take corrective action before attempting a restart.**

Possible reasons for not starting are :

- (1) Voltage drop at the motor terminals is more than allowed (look to confirmed data sheet).
- (2) The counter torque is too large to accelerate the rotor.
- (3) The driven machine is stuck, jammed or blocked.
- (4) The electrical connections have not been made according to drawings and standards.
- (5) One phase is missing or single phase power has been applied.
- (6) Any combination of the above.

4.2.3 Rotating Direction

- (a) Most TECO-Westinghouse motors can be operated in bi-directional rotation. However, when some special types, such as high speed 2P, certain large capacity motors, those with a non-reverse ratchet etc. should rotate in one direction, please ensure the rotation is in conformity with the directional arrow-mark shown on the attached nameplate.
 - (b) To reverse a bi-directional motor, cut the power and wait until the motor stops. Then interchange any two of the three phases.
-

4.2.4 Power Source, Voltage, Current

- (a) Ensure the voltage and frequency of the power source are identical to the ratings shown on the nameplate.
- (b) Voltage variation should be confined to $\pm 10\%$ of the rating and the three phase voltages should be in full balance.
- (c) Ensure the motor phase currents in no-load condition could be variably, within $\pm 5\%$ of the average values.

4.2.5 Power Source, Frequency

The variation of the frequency should be confined to $\pm 5\%$ of the rating. The aggregate variation of voltage and frequency should be confined to $\pm 10\%$ of the absolute value of the ratings.

4.2.6 Starting Time and Unusual Noises

ATTENTION !

Starting time is longer for the motors with large inertia. However, if starting time is longer than usual or if there is difficulty in starting, or there is abnormal noise, do not run the motor and refer to TECO-Westinghouse.

4.2.7 Bearing Temperature Rise

Following the initial start-up, the bearing temperatures should be closely monitored. The rise rate of bearing temperature is more indicative of impending trouble than is the actual temperature.

ATTENTION !

If the rise rate of the temperature is excessive; the motor exhibits excessive vibration and/or unusual noise, shut down the motor immediately. Before starting up the motor again a thorough investigation must be made to determine the cause.

If the bearing temperature rise and motor operation appear to be normal, operation should continue until the bearing temperature is stabilized.

Recommended limits on bearing temperature are as follows :

Alarm	Trip
95°C (203°F)	100°C (212°F)

When special synthetic lubrication oil was used under high ambient temperature case, such as 50~55°C, above temperature setting could be adjusted to alarm 110°C & trip 115°C after checking with factory engineers.

ATTENTION ! (For sleeve bearing)

- (1) Flood lubrication sleeve bearings without external lubrication supply, the bearing temperature must not be allowed to exceed 85°C in total.
- (2) Self-lube bearing or self-lube with water cooled, the rate of temperature rise should be from 11K to 14K for the first ten (10) minutes after starting up and approximately 22K at thirty (30) minutes. The rate of bearing temperature rise is a function of the natural ventilation and operating conditions.
- (3) When the rate of bearing temperature rise is less than $\pm 1\text{K}$ per (30) minutes, the bearing temperature is considered to steady conditions.
- (4) If the total bearing temperature exceeds 95°C, the motor should be shut down immediately and a thorough investigation must be made to determine the cause.

ATTENTION !

If the rise rate of the temperature is excessive; the motor exhibits excessive vibration and/or unusual noise, shut down the motor immediately. Before starting up the motor again, a thorough investigation must be made to determine the cause.

4.2.8 Noise and Vibration**ATTENTION !**

Any abnormal noise or vibration should be immediately investigated and corrected. Increased vibration can be indicative of a change in balance due to mechanical failure of a rotor part, a stator winding problem or a change in motor alignment.

(a) NEMA MG1, vibration limits at no load

Unfiltered Vibration Limits		
Speed, rpm	Rotational Frequency, Hz	Velocity, in./s peak (mm/s)
3600	60	0.15 (3.8)
1800	30	0.15 (3.8)
1200	20	0.15 (3.8)
900	15	0.12 (3.0)
720	12	0.09 (2.3)
600	10	0.08 (2.0)

(b) ISO 10816, overall vibration severity chart for customer's reference

Machine		Class I Small machine	Class II Medium machine	Class III Large rigid foundation	Class IV Large soft foundation	
in/s	mm/s					
Vibration Velocity (r.m.s.)	0.01	Unacceptable	Unacceptable	Unacceptable	Unacceptable	
	0.02					
	0.03					
	0.04					
	0.07					
	0.11					Satisfactory
	0.18					
	0.28					Unsatisfactory
	0.44					
	0.70					Unacceptable
	0.71					
	1.10					

4.2.9 Recommended Winding Temperature Settings

An electric motor normally has built in “over temperature protection devices” such as thermistors and RTD’s. They are set to trip at levels dependent upon the Class of Insulation of the motor windings. Motors designated Class F insulation have an allowable total temperature of 155°C in total. For those motors, the recommended alarm and trip settings are as below:

Alarm	Trip
140°C (284°F)	155°C (311°F)

4.2.10 Additional Points to Note

- The motor characteristic data includes values for the acceleration and safe stall times, when specified by the customer. If the motor fails to reach full speed, shut off the power immediately. Investigate thoroughly and take corrective action before attempting to restart.
- Each start of an induction motor subjects the motor to full inrush current with resulting heating of the stator and rotor windings. Each acceleration and repeated start can produce more heat than that produced and dissipated by the motor under full load.

The starting duty for which the motor is designed is shown by a nameplate mounted on the motor and must not be exceeded, if long motor life is expected. Abnormally terminal voltage drop and/or excessive load torque during motor start-up can cause extended acceleration time during which rotor speed is reduced and ventilation is minimized. This can cause rotor destroying or can lead to extreme shortening of the rotor life.

- The temperature rating of the motor is shown on the main nameplate as a temperature rise above an ambient temperature. If there is a service factor, it is also shown.

If the motor does not have stator winding temperature detectors and abnormal winding temperatures (as might be indicated by high discharge air temperature, odor, etc.) are suspected, the motor should be shut down immediately and an investigation made before further operation is attempted.

5. MAINTENANCE

5.1 Major Points in Regular Inspection and Maintenance



Maintenance and repairs must only be carried out by properly trained personnel.



Some testing, such as insulation resistance, usually requires the motor to be stopped and isolated from power supply(ies).

Routine inspection and maintenance are usually performed visually, audibly, by odor, and by means of simple meters.



High temperatures may arise under normal operating conditions on the motor surfaces, so touching should be prevented or avoided.

Keep away from moving and live parts.

Unless deemed necessary, do not remove guards while assessing the motor.

Timely replacement of worn parts can assure longevity and prevent breakdown.

Routine and regular inspection and maintenance are important in preventing breakdown and lengthening service life.

Owing to the varied time and circumstances in which motors are used, it is difficult to set the items and periods for regular inspection and maintenance. However, as a guide, it is recommended to be performed periodically according to factory maintenance program. Generally, the inspection scope is determined by the following factors:

- (a) Ambient temperature and ambient conditions (dust, humidity, other contamination).
- (b) Starting and stop frequency.
- (c) Troublesome parts usually affect motor operation.
- (d) Easily worn parts (ground brushes).
- (e) The importance of motors in the operational system should be duly recognized. Therefore, regular inspection and maintenance will prolong the life of the motor, especially when it is operating in severe conditions.

5.2 Motor Windings

- (a) Measurement of insulation resistance and standards to determine quality of insulation resistance, please refer to measures stated in 4.1.2 "Measurement of insulation resistance".
 - (b) Inspection of coil-ends:
 - (1) Grease and dust accumulated on coils may cause insulation deterioration and poor cooling effect.
 - (2) Moisture must not accumulate. Keep coils warm when motor is not in use (use space heater, if it's installed).
 - (3) Discoloring. This is mainly caused by overheating.
 - (c) Ensure no untoward change of wedges from original position occurs.
 - (d) Ensure the binding at the coil end is in its normal position.
-

5.3 Clean the Interior of the Motor

- (a) After a motor has been in operation for some time, accumulation of dust, carbon powder and grease etc., on the inside is unavoidable, and may cause damage. Regular cleaning and examination is necessary to assure top performance.
- (b) Points to note during cleaning:
- (1) If using compressed air or a blower:
 - a) Compressed air should be free of moisture. Be sure, that the dust and other materials can come out of motor housing, iron core and windings.
 - b) Maintain air pressure below 4 kg/cm², since high pressure can cause damage to coils.
 - (2) Vacuum

Vacuum cleaning can be used before and after other methods of cleaning, to remove loose dirt and debris. It is a very effective way to remove loose surface contamination from the winding without scattering. Vacuum cleaning tools should be non-metallic to avoid any damage to the winding insulation.
 - (3) Wiping

Surface contamination on the winding can be removed by wiping using a soft, lint-free wiping material. If the contamination is oily, the wiping material can be moistened (not dripping wet) with a safety type petroleum solvent.

In hazardous locations, a solvent such as inhibited methyl chloroform may be used, but must be used sparingly and immediately removed. While this solvent is non-flammable under ordinary conditions, it is toxic and proper health and safety precautions should be followed while using it.

ATTENTION !

Solvents of any type should never be used on windings provided with abrasion protection. Abrasion protection is a gray, rubber-like coating applied to the winding end-turns.



Adequate ventilation must always be provided in any area where solvents are being used to avoid the danger of fire, explosion or health hazards. In confined areas (such as pits) each operator should be provided with an air line respirator, a hose mask or a self-contained breathing apparatus. Operators should wear goggles, aprons and suitable gloves. Solvents and their vapors should never be exposed to open flames or sparks and should always be stored in approved safety containers.

- (4) Keep core ducts completely clean. The difference in temperature rise could be around 10°C before and after cleaning.



Fig. 14

5.4 Clean the Exterior of the Motor

- (a) On open ventilated motors, screens and louvers over the inlet air openings should not be allowed to accumulate any build-up of dirt, lint, etc. that could restrict free air movement.

ATTENTION !

Screens and louvers should never be cleaned or disturbed while the motor is in operation because any dislodged dirt or debris can be drawn directly into the motor.

- (b) If the motor is equipped with air filters, they should be replaced (disposable type) or cleaned and reconditioned (permanent type) at a frequency that is dictated by conditions. It is better to replace or recondition filters too often than not often enough. The Permanent type air filters can be cleaned with fresh water, make sure to let them dry before reinstalling.



Disposable type filter fitted into two filter supports.

Fig. 15



Permanent type filter.

Fig. 16

- (c) Totally enclosed air-to-air cooled and totally enclosed fan cooled motors require special cleaning considerations. The external fan must be cleaned thoroughly since any dirt build-up not removed can lead to unbalance and vibration. All of the tubes of the air-to-air heat exchanger should be cleaned using a suitable tube brush having synthetic fiber bristles (not wire of any type).
- (d) It is important to keep the external surfaces of any motor clean and free from buildup of dirt and debris as this can function as an insulating blanket causing the motor to overheat drastically and could reducing the life of the motor. Methods of cleaning external surfaces are: Scraping, brushing, dry ice blasting etc.

5.5 Maintenance of anti-friction bearing

5.5.1 Frequency of relubrication

The life of grease varies greatly as a result of types of model, revolution speed, temperature, operational conditions etc. It is, therefore, impossible to be precise about replenishment intervals. However, for normal direct coupling transmission, the periods shown in Table 1 may be used as a guide.

Remarks:

- (a) The periods shown in Table 1 should be halved where bearings are used for belt drive and/or in dirty, high ambient temperature or high humidity environments.
- (b) Please refer to the lubrication nameplate, if attached to the motor.
- (c) For bearing numbers outside the range of Table 1, please contact TECO-Westinghouse.
- (d) If the periods referred to Table 1 for drive-end bearing and opposite drive-end bearing are different, for the convenience of maintenance operation, one could take the shorter one for re-greasing schedule.

5.5.2 Kinds of grease

ExxonMobil Polyrex EM grease is standard for TECO-Westinghouse motors except some special models for which special grease will be shown on the lubrication nameplate. Please use identical grease or its equivalents when maintaining.

ATTENTION !

Do not mix different kinds of grease.

Mixing grease with different types of thickeners may destroy its composition and physical properties. Even if the thickeners are of the same type, possible differences in the additive may cause detrimental effects.

Table 1

Bearing number		600 RPM	720 RPM	750 RPM	900 RPM	1000 RPM	1200 RPM	1500 RPM	1800 RPM	3000 RPM	3600 RPM
62XX	6206~10										
63XX	12									2000Hrs	
72XX	13										
73XX	14									1000Hrs	
	15										
	16									720 Hrs	
	17									2000Hrs	
	18	3000Hrs								500 Hrs	
	20										
	22										
	24									1500Hrs	
	26										
	28									2000Hrs	
	30									1000Hrs	
	32									500 Hrs	
	34									1500Hrs	
	36										
	38	2000Hrs								1000Hrs	

Bearing number		600 RPM	720 RPM	750 RPM	900 RPM	1000 RPM	1200 RPM	1500 RPM	1800 RPM
NU2XX	NU214								
NU3XX	15								
	16								
	17								
	18	3000Hrs							
	20								
	22								
	24								
	26								
	28								
	30								
	32								
	34								
	36								
	38	2000Hrs							
	40								
	44								
	48	1000Hrs							

Bearing number		600 RPM	720 RPM	750 RPM	900 RPM	1000 RPM	1200 RPM	1500 RPM	1800 RPM
222XX	22220								
223XX	22								
	24	1000Hrs							
	26								
	28								
	30								
	32	500 Hrs							
	34								
	36								
	38	500 Hrs							
	40	300 Hrs							
	44								
	48	300 Hrs							

5.5.3 Grease quantity

The amount of grease per replenishment depends on the type, size and construction of the bearings. The minimum amount for replenishment of each bearing is shown in Table 2. **This replenishment amount is also the amount used at the time the motor is initially started.**

Table 2

Bearing No.		Amount of replenishment	Bearing No.		Amount of replenishment
62XX	6209~6210	30g	63XX	6308~6311	40g
72XX	6212	40	73XX	6312	60
NU2XX	6213	50	NU3XX	6313	80
222XX	6214	50	223XX	6314	80
	6215	60		6315	100
	6216	60		6316	100
	6217	80		6317	120
	6218	80		6318	120
	6220	100		6320	160
	6222	120		6322	220
	6224	120		6324	270
	6226	140		6326	300
	6228	160		6328	400
	6230	180		6330	450
	6232	200		6332	500
	6234	250		6334	600
	6236	300		6336	700
	6238	350		6338	800
	6240	400		6340	900
6244	450	6344	900		
6248	500	6348	900		

Suggested fill desirable, however, regrease until it replaces and the old grease entirely. The temperature of the bearing will initially increase because of the excess grease. After a few hours, the excess grease will be expelled through the exit tube and the bearing temperature will return to normal.

See Additional Greasing Information in Addendum A.

5.5.4 Re-Greasing



If relubrication is to be performed when the motor is running, stay clear of rotating parts.

It is advisable to re-grease while the motor is running to allow the new grease to be evenly distributed inside the bearing.

Before re-greasing, the inlet fitting should be thoroughly cleaned to prevent any accumulated dirt from being carried into the bearing with the new grease. The outlet or grease drain should be opened to allow the proper venting of old grease.

Use a grease gun to pump grease through grease nipple into bearings slowly. After re-greasing, operate the motor for 10-30 minutes to allow any excess grease to vent out.

5.5.5 Oil Re-lubrication (For oil lubrication types only)

Maintain proper lubrication by checking the oil level periodically and adding oil when necessary. Because of the initial clearing action of the bearing and the expansion of the oil as it comes up to operating temperature, the oil level will be higher after the motor has been in operation for a while than it is with the motor at standstill.

Overfilling should be avoided not only because of the possibility that expansion may force the oil over the oil sleeve and on to the rotor, but also because too high an operating oil level prevents the bearing from clearing itself of excess oil. The resultant churning can cause extra loss, high temperatures, and oxidized oil. If, the oil level goes above the maximum shown on the sight gauge during operation, drain enough oil to bring the level back within the recommended operating range.

Do not permit the operating level to fall below the minimum shown on the sight gauge.

ATTENTION !

Should it ever become necessary to add excessive amount of make-up oil, investigate immediately for oil leaks.

Change the oil at regular intervals. The time between oil changes depends upon the severity of operating conditions and, hence, must be determined by the motor user. Two or three changes a year is typical, but special conditions, such as high ambient temperature, may require more frequent changes. Avoid operating the motor with oxidized oil.

Use only good quality, oxidation-corrosion-inhibiting turbine oils produced by reputable oil companies. The viscosity of the oil to be used depends upon the type and size of the bearing, its load and speed, the ambient temperature, and the amount and temperature of the cooling water (if used). The lubrication nameplate or instructions with each motor specifies the viscosity range of oil suitable for average conditions. The usual oil viscosity recommendations are summarized in Table 3. Operation in ambient temperatures that are near or below freezing may require preheating the oil or the use of special oil. Whenever the motor is disassembled for general cleaning and reconditioning, the bearing housing may be washed out with a suitable cleaning solvent. Be sure that the oil metering hole is clear, and then dry the housing thoroughly before reassembly, and ensure all traces of cleaning solvent has been removed.

Table 3 oil viscosity for vertical motors**

Bearing Type	Oil viscosity	Range of pole
Angular contact ball (72XX , 73XX)	ISO VG32 (150 SSU/100°F)	2 pole
	ISO VG68 (300 SSU/100°F)	4 pole and above
Spherical roller (293XX , 294XX)	ISO VG68 (300 SSU/100°F)	4 , 6 pole
	ISO VG150 (700 SSU/100°F)	8 pole and above

**Note: Where a lubrication nameplate is attached to the motor, use the lubrication oil it stipulates.

5.5.6 Cleaning and Installation of Bearings

- (a) Apply the proper amount of grease to disassembled parts of the bearing after they have been thoroughly cleaned with high quality cleaning oil. Then protect them from contamination before and during assembly.
- (b) Bearing installation

ATTENTION !

Before installing the bearings, make sure that the shaft mounted parts behind the bearings are in place before installation.

Since the bearing is a high precision component, it is important to avoid ingestion of dust and foreign matter and hammering during cleaning and installation. Be extremely careful and ensure clean conditions exist during installation and assembly.

ATTENTION !

The best way for bearing installation is heat shrinking. Knocking and hammering during installation should be absolutely avoided.

The bearing should be heated in a bath of clean oil to a temperature of approx. 80°C or using an induction bearing heater with a temperature probe. After warming, slide the bearings in place quickly and nimbly so that it does not shrink onto the shaft before being fully in position. Take care to keep the bearing straight during installation and ensure it is properly seated against the shoulder. Maintain pressure against the shoulder for several seconds to ensure it does not slide back from the shoulder, or become “cocked” on the journal.

Grease the bearing after the temperature returns to normal, and then reassemble the motor.

5.6 Maintenance of Non-Reverse Ratchet Mechanism

5.6.1 Non-Reverse Ratchet Mechanism

In the pump piping system, a check valve and a stop valve should be installed in the discharge line. The check valve, placed between the pump and the stop valve, is to protect the pump from reverse flow and excessive back pressure. The stop valve is used in priming, starting and when shutting down the pump. It is advisable to close the stop valve before stopping the pump. This is especially important when the pump is operated against a high static head.

TECO-Westinghouse vertical high thrust motors are equipped with non-reverse ratchet (N.R.R.) mechanism only when requested by the pump manufacturer. The NRR may consist of a pin type assembly – see illustration (A), or a ball type assembly – see illustration (B). Typical construction of N.R.R. mechanism is shown as Fig.19 below.



ITEM	NAME
104	RATCHET
214	BEARING SEAT
402	EXTERNAL FAN
704	RATCHET PIN CARRIER
816	RATCHET PIN(BALL)

Fig. 19

The N.R.R. mechanism keeps the pump and motor from rotating in the reverse direction. Thus prevents damage from over speeding and damage to water-lubricated pump shaft bearings when, on shutdown, the falling water column tends to drive the pump in the reverse direction.

In normal operation, the ratchet pins or balls are lifted by the ratchet teeth and are held clear by centrifugal force and friction as the motor comes up to speed. When power is removed, the speed decreases and the pins or balls fall. At the instant of reversal, a pin or ball will catch in a ratchet tooth and prevent backward rotation.

5.6.2 Service Life

The service life of ratchet pins or balls depends not only on the reverse shock load between the pin or ball and ratchet tooth when pump stopped but also the frequency of pump starting and stop in application.

Over time pins specifically can become deformed due to this reverse shock load, causing the up and down motion of ratchet pins to become sluggish or jammed and unusual noises will arise.

The recommended replacement period for these ratchet pins is every three (3) years. If the reverse shock load is greater than 30% of motor rated torque or the starting frequency is more than twice

per day, then the replacement period is to be halved.

ATTENTION !

The check valve and stop valve in the discharge line should be regularly inspected and maintained to ensure the normal operation of these valves. This is important to protect the pump and motor from damage and increase the service life of the N.R.R. mechanism.

5.6.3 Disable the N.R.R. mechanism

Motor with N.R.R. mechanism only can run in uni-direction. The motor can change to suitable for bi-directions by disabling the N.R.R. mechanism. The N.R.R. mechanism can be disabled in the following manner:

- (a) Remove the fan cover or weather cover on the top of motor.
- (b) Remove the external fan or cover on the top of ratchet pin carrier.
- (c) Take out the ratchet pin or ball.
- (d) Replace the external fan or cover
- (e) Replace the fan cover or weather cover

ATTENTION !

The N.R.R. mechanism is refine-balanced by adding weights to the external fan or cover. Before removing the external fan or cover, it should be marked and replaced in the same position to retain proper balance.

5.7 Dismantling and Assembly Procedure

5.7.1 Dismantling and Assembly Procedure

Please see the drawing in Appendix 4.

Brackets w/anti-friction bearing	Dismantling brackets	Assembly
TEFC	<p>(一) Upper bearing</p> <ol style="list-style-type: none"> 1. Remove the fan cover (01) & external fan (02). 2. Remove LK nut (18) and pull out ratchet pin carrier (17) . 3. Remove ratchet (16),then you can pull out bearing seat(15). 4. Take off bearing(13) from bearing seat by Remove outside retaining ring. <p>(二) Lower bearing</p> <ol style="list-style-type: none"> 1. Remove LK nut(18) and out bearing cover-outer(21) and grease flinger(20) ,then remove flange bracket(11) bolts and pull out 2. Pull out from bearing cover-inner(22),then lower bearing come out from shaft. 	<ol style="list-style-type: none"> 1. Check the bearing assembly. Keep each part very clean. 2. Tighten securing bolts by reverse step of dismantling. 3. Refer to 5.7.2 to adjust the endplay.



5.7.2 Endplay Adjustment

Endplay is defined as the total axial float of the rotor. When motor is dismantled for any reason, the rotor endplay must be adjusted. During reassemble the bearing, it is necessary to make sure that endplay must be within the proper range.

In order to adjust the endplay setting correctly, a dial indicator should be used to read the axial float of rotor. The upper bearing lock nut should be turned until no further upward movement of the shaft is indicated. Then loosen the lock nut until 0.005" to 0.008" endplay is shown. Finally, lock the lock nut with lock washer.

5.8 Records of Operation and Maintenance

5.8.1 Objective

- (a) Fully understand the purpose of the motors in operation and discover any abnormalities in advance.
- (b) Prevent negligence and omissions in maintenance.
- (c) Map pertinent maintenance plans after fully understanding the operation of the motor.
- (d) Know the lifespan of the depreciating parts to determine the amount of spare parts to be kept.
- (e) Plan the amount of spare motors and replacement parts to repair the motors in operation according to actual situation and schedule.

5.8.2 Records of Operation

- (a) It is advisable to use a primed form with yes/no or right/wrong selections for the operator to easily fill out.
- (b) Principle contents :
 - (1) Serial number of machine.
 - (2) Load machine type.
 - (3) Models and specifications of motors.
 - (4) Three-phase voltage.
 - (5) Three-phase current.
 - (6) Temperature of a motor and bearings when in operation.
 - (7) Ambient temperature, humidity, weather, date and time.
 - (8) Time of start and stop.
 - (9) Special remarks.
 - (10) Operator's name.

5.8.3 Records of Maintenance

- (a) It is advisable to use a primed form with yes/no or right/wrong selections for the operator to easily fill out.
 - (b) Principle contents :
 - (1) Serial number of machine.
 - (2) Load machine type.
 - (3) Models and specifications of motors.
 - (4) Ordinary operating conditions and data.
 - (5) Cause, date and disposition measures at breakdown.
-

- (6) Quantity and name of replaced spare parts.
 (7) Date of maintenance and initial operation.
 (8) Items and date of maintenance.
 (9) Special remarks.
 (10) Name of maintenance personnel.

6. FAULT FINDING AND RECOGNITION

Type of Breakdown	Symptoms	Possible causes	Remedies
Fail to start without load	Motionless and soundless	Power-off	Consult power company
		Switch-off	Switch-on
		No fuse	Install fuse
		Broken wiring	Check wiring and repair
		Broken lead	Check wiring and repair
		Broken windings	Check windings and repair
	Fuse blowing. (Automatic switch trips off, slow start with electromagnetic noise)	Short circuit of circuit switches	Check circuit switches and replace
		Incorrect wiring	Check wiring according to nameplate
		Poor contact at terminals	Lock tightly
		Windings grounded	Factory repair
		Broken windings	Factory repair
		Poor contact of circuit switches	Check and repair
		Broken wiring	Check and repair
		Poor contact of starting switches	Check and repair
Loading after start	Fuse blowing. Fail to restart due to trip-off of automatic switch	Insufficient capacity of fuse	Replace fuse if wiring permits
		Overload	Lighten load
		High load at low voltage	Check circuit capacity and reduce load
	Overheating motor	Overload or intermittent overload	Lighten load
		Under-voltage	Check circuit capacity and power source
		Over-voltage	Check power source
		Ventilation duct clogged	Remove the foreign matter in the duct
		Ambient temperature exceeds 40°C	Correct insulation class F, or lower ambient temperature.
		Friction between rotor and stator	Factory repair
		Fuse blown (Single-phase rotating)	Install the specified fuse
		Poor contact of circuit switches	Check and repair
		Poor contact of circuit starting switches	Check and repair
		Unbalanced three-phase voltage	Check circuit or consult power company

Kinds of Breakdown	Symptoms	Possible causes	Remedies	
Loading after start	Speed falls sharply	Voltage drop	Check circuit and power source	
		Sudden overload	Check machine	
		Single-phase rotating	Check circuit and repair	
	Switch overheat	Insufficient capacity of switch	Replace switch	
		High load	Lighten load	
	Bearing overheating	Lack of oil	Add oil	
		Lack of grease	Add grease	
		Misalignment between motor and machine shafts	Re-align	
		Over speed of bearing outer-ring	Adjust bracket	
		High bearing noise	Replace the damaged bearing	
Noise	Electromagnetic noise induced by electricity	Occurrence from its first operation	May be normal	
		Sudden sharp noise and smoking	Short circuit of windings Should be repaired at factory	
	Bearing noise	Churning sound	May be normal noise from grease circulating through the bearing	
		Rattling noise as result of poor lubrication	Add Grease	
		Larger noise	Inspect cause -replace the damaged bearing	
	Mechanical noise caused by machinery	Loose belt sheave	Adjust key and lock the screw	
		Loose coupling or skip	Adjust the position of couplings, lock key and screw	
		Loose screw on fan cover	Lock fan cover screw tightly	
		Fan rubbing	Adjust fan position	
		Rubbing as a result of ingress of foreign matters	Clean motor interior and ventilation ducts	
		Wind noise	Noise induced by air flowing through ventilation ducts	
		Induced by conveyance machine	Repair machine	
	Vibration	Electromagnetic vibration	Short circuit of windings	Factory repair
			Open circuit of rotor	Factory repair
		Mechanical vibration	Unbalanced rotor	Factory repair
Unbalanced fan			Factory repair	
Broken fan blade			Replace fan	
Unsymmetrical centers between belt sheaves			Align central points	
Central points of couplings not in alignment			Adjust the alignment between motor and driven equipment	
Improper mounting installation			Check mounting and alignment	
Motor mounting bed is not strong enough			Reinforce mounting bed	
Mounting bed vibration caused by near machines			Eliminate the vibration source near motor	
Remarks:				
(1) Circuit switches: These include knife switches, electromagnetic switches, fuse and other connection switch etc.				
(2) Starting switches: These include Delta-Star starters, compensate starters, reactance starters, resistor starters, starting controllers etc.				

7. RECYCLE

7.1 Introduction

TECO-Westinghouse obeys its environmental and protection policies. TECO-Westinghouse has always been committed, through the use of recyclable and life cycle analysis of the results, to improve environmental protection products. Products, production processes or flow designs all reflect the concept of environmental protection. TECO-Westinghouse's environmental management system through the ISO 14001 certification is used to implement an environmental policy tool.

The following guidelines only deal with the suggestions of environmental treatment on the equipments. Customer shall be responsible for compliance with local regulations. This manual may not include some of the customer's specific content. Project document provides additional documentation.

7.2 Materials Average Content

When producing electrical equipments, the average material content used are as follows:

Material	Die-casting frame Induction machinery	Steel plate frame Induction Machinery
Steel	45 – 56 %	79 - 83 %
Copper	8 – 10 %	12 – 14 %
Cast iron	32 – 43 %	1 – 3 %
Aluminum	0 – 5 %	0 - 1 %
Insulation materials	1 - 2 %	2 – 4 %
Stainless steel	Below 1 %	Below 1 %
Other	Below 1 %	Below 1 %

7.3 Packing Materials Recycling

When the equipment arrives to the site/destination, the packing materials should be removed.

- All wood-made packing materials can be burned.
- The packing materials used in sea shipping (impregnated wood) if applicable, must be recycled according to local regulations.
- The plastic materials around equipments can be recycled.
- The anticorrosive agent covering the surface of equipment can be cleaned by gasoline-based cleaner or wipers. Treating the wipers must comply with local regulations.

7.4 Disassembly of Equipment

Disassembling equipment is a basic operation because equipment is assembled by bolts. However, due to the heavy weight of equipment, the operator must be required to have received training in handling the transportation of heavy loads to avoid any danger.

7.5 Classification of Different Materials

7.5.1 Frame, Bracket (bearing housing), Cover and Fan

These parts are made of structural steel and can be recycled according to local regulations. All of auxiliary equipment, cables and bearings must be removed before melting.

7.5.2 Parts with Electrical Insulation

The stator and rotor are the main part of machinery that include electrical material. Some auxiliary parts also include similar materials and should use the same methods of disposal. These materials include each insulator in outlet box, exciter, transformer with adjustable voltage and current function, cables, wires, corona discharger and capacitor. Some parts are used for synchronous machinery and some are used for other equipment.

All of these parts are in an inert state when equipments are completed.

Some parts (especially stator and rotor components) include a large amount of copper and can be separated by appropriate heat treatment. The organic adhesive materials in insulation materials can be gasified. In order to ensure proper gas combustion, burner should provide an appropriate supplementary burner. In the combustion process of heat treatment, the following conditions are recommended to minimize the material distributed processing:

Temperature of Heat treatment : 380- 420°C (716- 788°F)

Duration : Processing object should be kept at that temperature for at least 5 hours when reaching to 90% of target temperature.

Supplementary gas combustion temperature for adhesives smoke begin between: 850-920 ° C (1562-1688 ° F) Flow rate: adhesives smoke in the combustion chamber should be kept at least three seconds.

Note: The distribution of substances include O₂, CO, CO₂, NO_x, C_xH_y gas and micro-particles. The user shall be responsible to make ensure that the process complies with local regulations.

Note: You should pay particular attention to thermal processes and heat treatment equipment maintenance, so as not to cause a fire or create an explosion hazard. Since this work will use a variety of devices, TECO-Westinghouse cannot provide a detailed maintenance guideline for treatment process or equipment. Customers will be responsible for dealing with these issues.

7.5.3 Permanent Magnet

If permanent magnet synchronous machineries will be totally melted, it's not necessary to deal with the permanent magnets.

In order to achieve a more complete recovery and removal of equipment or if the rotor will be sent out after recovery, we suggest doing permanent magnet demagnetization. Rotor can be heated in the furnace until the temperature of a permanent magnet reaches 300 °C (572 °F) to achieve degaussing purpose.



Opening or disassembly of permanent magnet synchronous machinery or removal of the rotor of such equipment will produce stray magnetic fields. This may interfere with or damage other electrical or electromagnetic devices and components, such as cardiac pacemakers, credit cards, etc.

7.5.4 Hazardous Waste

The grease in the oil lubrication system is hazardous waste and must be treated by local regulations.

7.5.5 Buried Waste

All insulation materials can be treated as landfill waste.

Appendix 1. Daily Inspection

Checking Point	Checking Item	Description or inspection parts	Method	Criteria or Notes
1. Bearing	Oil supply	Oil quantity	Check oil level from oil sight gauge.	In the middle of oil sight gauge.
		Oil pressure (forced oil lubrication only)	Check oil supply pressure gauge near inlet pipe or supply unit.	Within $\pm 20\%$ of specified pressure.
		Oil ring rotation (horizontal sleeve bearing only)	Check oil ring from window at 12 o'clock.	Rotating smoothly
	Oil leakage	Shaft · labyrinth seal · piping connection · parting line of housing	Inspect by eye and touch by hand.	Dampness around housing is normal. But oil accumulation on floor should be checked.
	Temperature	Bearing temperature detector	Check the value is the same as normal.	Recommendation : See 4.2.8
	End play	Axial fluctuation of shaft	Inspect by eye.	The shaft shoulder should not touch the liner.
		Magnetic center	Inspect the magnetic center pointer on drive end.	$\pm 3\text{mm}$
	Vibration	Ref to 4.2.9	If the vibration level is higher than normal, please measure the spectrum by instrument.	Analyze the spectrum.
Noise	Ref to 4.2.9	Listen for unusual noise	Assess noise, stop and inspect if necessary	
2. Stator	Temperature	Winding temperature detector	Check the value is the same as normal.	Recommendation : See 4.2.10
	Load	Voltage · current	Check the value from control panel	Voltage variation $< 10\%$ Current $<$ rated current
3. Cooler	Water supply	Water quantity	Check the water flow relay or indicator & temperature.	The water flow rate and temperature limitations are shown on outline drawing.
4. Filter	Dust or pollution	Clean filter	Clean by fresh water	Clean filter
5. Others	Odor	Windings & Bearings	Check winding and bearing temperature monitors	Check load / cooling air flow, oil condition.

Appendix 2. Monthly Inspection

Checking Point	Checking Item	Description or inspection parts	Method	Criteria or Notes
1. Bearing	Oil supply	Oil quantity	Check oil level from oil gauge.	In the middle of oil gauge. If the oil quantity is low , please add oil and check for leaks
	Oil leakage	Shaft 、 labyrinth seal 、 piping connection 、 parting line of housing	Inspect by eye and touch by hand.	If oil is leaking, it is important to find the root cause.
2. Stator	Temperature	Winding temperature detector	Check the value if the same as normal.	Recommendation : See 4.2.10
	Appearance	Bolts/nuts for bracket or frame etc.	Inspect by eye and touch by hand.	Re-tighten all loose.
	Resistance	Winding	500VDC/1000VDC megger. Once every three months at least.	Ref to “Operation” 4.1.2 measurement of insulation resistance.
3. Cooler	Water supply	Water quantity	Check the water flow relay or indicator & temperature.	The water flow rate and temperature limitations are shown on outline drawing.
4. Coupling	Appearance	Bolts/nuts	Inspect by eye and touch by hand.	Re-tighten all loose bolts.
5. Space Heater	Resistance	Heater wire	500VDC megger.	Ref to “Operation” 4.1.2 measurement of insulation resistance.

Appendix 3. Regular Inspection

Item	Checking Point	Description	Regular Inspection			
			In situ Exterior surface inspection	In situ Open inspection	Removed for Disassembly inspection	
1. Inspection before disassembly	(1)	Vibration	Measure and record the vibration levels for reference	○	○	○
	(2)	Temperature	Record bearing, winding & ambient temperature for reference.	○	○	○
	(3)	Coupling	Measure the mounting and shaft end dimensions. Check if any bolts are loose. Check if there are any mounting hole, key & keyway deformation.			○
	(4)	Alignment	Check and record the alignment for reference			○
	(5)	Anchor bolt, mounting bolt & nut	Check if there are any parts loose. Check condition of all nuts , bolts, Replace if defective.		○	○
	(6)	Adjusting shims	Check if rusty, damaged and replace if damaged.			○
	(7)	Shaft vibration	Measure the shaft vibration value and record.			○
	(8)	Foundation level	Check for any deformation that may have occurred.			○
	(9)	Air gap	Measure this value and record in 3 places at least for each end.			○
2. Sleeve bearing inspection	Sleeve bearing	According to RENK "Instructions for Maintenance and Inspection".		○	○	
3. Stator inspection	(1)	Winding resistance	Use 500VDC/1000VDC megger to measure and record results.	○	○	○
	(2)	Winding appearance	Check if any dust or oil contamination on winding coil			○
	(3)	Coil end	Check coils for loose blocking, lashings, end rings.			○
	(4)	Coil insulation	Check coil insulation material for wear, discolouration or damage			○
	(5)	Cable lead	Check if lead insulation broken, cracked or damaged.			○
	(6)	Terminal lug	Check for loose or damaged lugs or terminals.			○
	(7)	Coil wedge	Check for loose or damaged slot wedges.			○
	(8)	Air guide	Check each bolt & nut to see if any is loose.			○

Appendix 3. Regular Inspection (continue)

Item	Checking Point	Description	Regular Inspection			
			In situ Exterior surface inspection	In situ Open inspection	Removed for Disassembly inspection	
4. Rotor inspection	(1)	Rotor appearance	Check if any dust or oil contamination is on rotor.			<input type="radio"/>
	(2)	Rotor bar	Check for loose or damaged bars Check rotor bar end ring welds.			<input type="radio"/>
	(3)	Rotor core	Check for loose or damaged laminations.		<input type="radio"/>	<input type="radio"/>
5. Fan	Fan	Check welded portions for cracks, bolts & nuts, any built up dirt or rust.				<input type="radio"/>
6. Inspection before operation	(1)	Winding resistance	Use 500VDC/1000VDC megger to measure, record results.	<input type="radio"/>	<input type="radio"/>	<input type="radio"/>
	(2)	Supply lead connection	Check all incoming supply leads correctly connected.		<input type="radio"/>	<input type="radio"/>
	(3)	Protection relay	Check protection relay in normal operation.	<input type="radio"/>	<input type="radio"/>	<input type="radio"/>
	(4)	Lubrication oil	Oil level at the middle of oil gauge. Oil inlet pressure correct and oil drains smoothly.	<input type="radio"/>	<input type="radio"/>	<input type="radio"/>
	(5)	Alignment	Check and record the alignment.			<input type="radio"/>
	(6)	Anchor bolt & mounting bolt	Check all mounting bolts are securely tightened.		<input type="radio"/>	<input type="radio"/>
	(7)	Driven equipment	Check if all driven equipment is ready for operation.	<input type="radio"/>	<input type="radio"/>	<input type="radio"/>
	(8)	Cooling water	Check cooling water flow rate & quantity.	<input type="radio"/>	<input type="radio"/>	<input type="radio"/>
7. Inspection before starting	(1)	Rotational direction	Check rotational direction.	<input type="radio"/>	<input type="radio"/>	<input type="radio"/>
	(2)	Oil ring	Check if oil ring runs smoothly.	<input type="radio"/>	<input type="radio"/>	<input type="radio"/>
	(3)	Noise	Check there is no abnormal noise.	<input type="radio"/>	<input type="radio"/>	<input type="radio"/>
	(4)	Vibration	Check if vibration is normal.	<input type="radio"/>	<input type="radio"/>	<input type="radio"/>
	(5)	Bearing temperature	For test run, please keep monitoring for 2hrs at least.	<input type="radio"/>	<input type="radio"/>	<input type="radio"/>
	(6)	Oil level	Check oil level.	<input type="radio"/>	<input type="radio"/>	<input type="radio"/>
	(7)	Current	Make sure current is below rated value shown on nameplate.	<input type="radio"/>	<input type="radio"/>	<input type="radio"/>

Note :

- (a) Disassembly inspection : removing the rotor to inspect the stator & rotor.
Recommendation : every four (4) years, but depends on operation environment conditions & machine type.
 - (b) Open inspection : inspect the maximum possible portions without removing rotor.
Recommendation : every two (2) years, but depends on operation environment conditions & machine type.
 - (c) Exterior surface inspection
Recommendation : every year.
-

Appendix 4. Typical Motor Cross Sectional Drawings: SCIM, TEFC



Item	Name	Item	Name
01	FAN COVER(N.D.E)	14	OIL SEPARATOR
02	EXTERNAL FAN	15	BEARING SEAT
03	VERTICAL PLASH COVER	16	RATCHET
04	PLUG	17	RATCHET PIN OR BALL CARRIER
05	COVER	18	LK NUT
06	INSULATION BRACKET		
07	INNER FAN		
08	HOOK		
09	ROTOR		
10	S CORE		
11	FLANGE BRACKET		
12	LOWER BEARING		
13	UPPER BEARING		

Appendix 4-1. Typical Motor Cross Sectional Drawings: SCIM, TEFC



Appendix 4-2. Typical Motor Cross Sectional Drawings: SCIM, TEFC



35	TERMINAL BOX
34	SHAFT
33	GREASE FLINGER
32	BEARING COVER-OUTER
31	BEARING
30	STOP RING-BEARING
29	FLANGE BRACKET
28	GREASE NIPPLE
27	PRE-LOAD SPRING
26	BEARING COVER-INNER
25	OUTSIDE RETAINING RING
24	FRAME
23	ROTOR ASSY
22	STATOR
21	HOOK
20	BRACKET
19	PLUG BOLT
18	SERRET ELBOW
17	OIL GAUGE
16	O RING
15	PLUG
14	BEARING
13	OIL BAFFLE
12	OIL BAFFLE
11	RATCHET
10	BEARING SEAT
09	RATCHET PIN
08	EXTERNAL FAN
07	COUPLING
06	LK NUT
05	LK WASHER
04	OIL BAFFLE
03	OIL SEPARATOR
02	OUTSIDE RETAINING RING
01	WEATHER COVER
ITEM	NAME

Appendix 5. Typical Motor Cross Sectional Drawings: ODP



Item	Name	Item	Name
01	FAN COVER	13	FLANGE BRACKET
02	EXTERNAL FAN	14	AIR GUIDE
03	RATCHET	15	GREASE NIPPLE
04	PLUG	16	BEARING SEAT
05	BRACKET	17	OIL BAFFLE
06	OIL GAUGE	18	COVER
07	WINDOW COVER	19	UPPER BEARING
08	SCREWED GLOBE VALVE	20	OIL SEPARATOR
09	S CORE	21	LOWER BEARING
10	ROTOR	22	OIL DRAIN COVER ASSY
11	WINDOW	23	COUPLING
12	INNER FAN	24	LK NUT

Appendix 5-1. Typical Motor Cross Sectional Drawings: ODP



ITEM	NAME
01	WEATHER COVER
02	COUPLING
03	LK NUT
04	LK WASHER
05	BEARING
06	STOP RING-BEARING
07	HOOK
08	TERMINAL BOX
09	SHAFT
10	OUTSIDE RETAINING RING
11	SCREEN
12	STOP RING-BEARING
13	FLANGE BRACKET
14	OUTSIDE RETAINING RING
15	SHAFT SLEEVE
16	BEARING
17	SCREEN
18	BEARING COVER-INNER
19	ROTOR
20	STATOR
21	FRAME
22	BEARING COVER-INNER
23	BRACKET
24	OIL SEAL
25	GREASE NIPPLE
26	BEARING COVER-OUTER
27	GREASE FLINGER
28	EXTERNAL FAN
29	RATCHET PIN(BALL TYPE)

Appendix 5-2. Typical Motor Cross Sectional Drawings: ODP



ITEM	NAME
01	WEATHER COVER
02	COUPLING
03	LK NUT
04	LK WASHER
05	BEARING SEAT
06	BEARING
07	OUTSIDE RETAINING RING
08	HOOK
09	OIL SEPARATOR
10	TERMINAL BOX
11	SHAFT
12	SCREEN
13	FLANGE BRACKET
14	STOP RING-BEARING
15	OUTSIDE RETAINING RING
16	GREASE FLINGER
17	OIL SEAL
18	BEARING COVER-OUTER
19	BEARING
20	GREASE NIPPLE
21	SCREEN
22	BEARING COVER-INNER
23	ROTOR
24	STATOR
25	FRAME
26	O-RING
27	AIR GUIDE
28	PLUG
29	SEREET ELBOW
30	OIL GAUGE
31	BRACKET
32	PLUG
33	RATCHET
34	OIL SEAL
35	EXTERNAL FAN
36	RATCHET PIN(BALL TYPE)
37	COVER

Appendix 6. Typical Motor Cross Sectional Drawings: SCIM, TEWC



Item	Name	Item	Name
01	FAN COVER	12	LOWER BEARING
02	EXTERNAL FAN	13	OIL DRAIN COVER ASSY
03	OIL BAFFLE	14	LK NUT
04	COVER	15	RATCHET PIN OR BALL CARRIER
05	BEARING HOUSING	16	RATCHET
06	BRACKET	17	BEARING SEAT
07	SCORE	18	SPRING
08	COOLER	19	OIL SEPARATOR
09	ROTOR	20	UPPER BEARING
10	FLANGE BRACKET	21	SCREWED GLOBE VALVE
11	GREASE PIPE		

Appendix 7. Typical Ball Bearing Construction Drawing



Item	Name	Item	Name
1	Ball Bearing	6	Grease Nipple & Pipe
2	Grease Flinger-Inner	7	Shaft
3	Bearing Cover-Inner	8	Bracket
4	Grease Flinger-Outer	9	Dust Flinger
5	Bearing Cover-Outer		

Please be noted :

1. Use sealing compound on screws (A) and the surface between parts (B).
2. In order to avoid abnormal bearing noise, please fill new grease as full as possible between races during the change process of bearing.

Appendix 7-1. Typical Ball Bearing Construction Drawing



Appendix 8. Typical Roller Bearing Construction Drawing



Item	Name	Item	Name
1	Roller Bearing	5	Bearing Cover-Outer
2	Grease Flinger-Inner	6	Grease Nipple & Pipe
3	Bearing Cover-Inner	7	Shaft
4	Grease Flinger-Outer	8	Bracket

Please be noted :

1. Use sealing compound on screws (A) and the surface between parts (B).
2. In order to avoid abnormal bearing noise, please fill new grease as full as possible between races during the change process of bearing.

Appendix 9. Typical Ball Bearing with Insulation Bushing Construction Drawing



Item	Name	Item	Name
1	Ball Bearing	7	Shaft
2	Grease Flinger-Inner	8	Bracket
3	Bearing Cover-Inner	9	Insulation Plate
4	Grease Flinger-Outer	10	Insulation Bushing
5	Bearing Cover-Outer	11	Dust Flinger
6	Grease Nipple & Pipe		

Please be noted :

1. Use sealing compound on screws (A) and the surface between parts (B).
2. In order to avoid abnormal bearing noise, please fill new grease as full as possible between races during the change process of bearing.

Appendix 10. Typical Thrust Bearing Assembly Drawing (Vertical Machine)



Item	Name	Item	Name
1	Thrust Bearing	8	Ratchet Pin Carrier
2	Ball Bearing	9	Ratchet Pin or Ball
3	Spring	10	Lock Nut
4	Insulation Bushing	11	External Fan
5	Oil Standpipe	12	Oil Lever Gauge
6	Upper Bearing Runner	13	Upper Bracket
7	Non-Reverse Ratchet		

Please be noted :

Use sealing compound on spigot of oil tank (A), between non-reverse ratchet (item 7) and upper bracket (item 13).

Appendix 11. Shaft Earth Brush Assembly Drawing (TAC)



Item	Name	Item	Name
010	Brush	030	Plain Washer
020	CR C SCREW	040	T Lock Washer

Appendix 12. Shaft Earth Brush Assembly Drawing (TECO)



Item	Name	Item	Name
010	Support	060	Plain Washer
020	Hex Bolt	070	S Washer
030	S Washer	080	Hex Nut
040	Brush Holder	090	Brush Spring Assembly
050	Hex Bolt	100	Brush

Please be noted :

Directly connect grounding by a separate wire between one of M6 tap holes (A) on brush holder (item 040) and earth is highly recommended.

Appendix 13. Bolt Torque (kg-cm)

BOLD SIZE	THREAD PITCH	MILD STEEL (property class 4.6 or 4.8)		BRASS
		WITHOUT SPRING WASHER	WITH SPRING WASHER	WITHOUT SPRING WASHER
M4	0.7	25~34	10~13	8.4~11.3
M5	0.8	38~52	20~25	16.2~22.0
M6	1.0	68~97	40~50	28~38
M8	1.25	161~230	90~110	68~91
M10	1.5	288~416	180~230	125~183
M12	1.75	462~660	320~400	230~310
M16	2.0	1010~1440	800~1000	560~760
M20	2.5	2100~3000	1600~2000	1090~1470
M24	3.0	3800~5400	2800~3500	1870~2500
M30	3.5	8000~11500	5800~7250	3800~5100
M36	4.0	14000~20000	10000~12500	6500~8800

Appendix 14. TECO Worldwide Operations**HEAD OFFICE**

Teco Electric & Machinery Co. Ltd
10F. No. 3-1 Yuan Cyu St.
Nan-Kang, Taipei 115
Taiwan R.O.C.
Tel: +886 2 6615 9111
Fax: +886 2 6615 2253
www.tecomotor.com.tw

UNITED STATES

Teco-Westinghouse Motor Company
PO Box 227 (78680-0277),
5100 N.IH35 Round Rock Texas 78681 USA
Tel: +1 512 255 4141
+1 800 873 8326
www.tecowestinghouse.com

CANADA

Teco-Westinghouse Motors Inc. (Canada)
18060-109th Ave
Edmonton, Alberta T5S 2K2 Canada
Tel: +1 780 444 8933
Fax: (780) 486-4575
24 HR Emergency Pager: (780) 419-7734
Toll Free: 800-661-4023
Fax Toll Free: 888-USE-TWMI
www.twmi.com

MEXICO

TECO-Westinghouse Motor Company, S.A. de
C.V.
CIRCUITO MEXIAMORA PONIENTE 321
PARQUE SANTA FE GUANAJUATO
PUERTO INTERIOR
SILAO, GUANAJUATO CP 36275, Mexico
E-mail: ventas@tecowestinghouse.com
Tel: +52 (472) 748 9016 al 20

CHINA

Suzhou Teco Electric & Machinery Co., Ltd
No. 1 Changjiang W.Rd.South-Dam
Industrial Park Liuhe Zhen, Taicang City,
Suzhou
Jiangsu Province, PRC
Tel: +86 512 5361 9901
Fax: +86 512 5396 1058

Wuxi Teco Electric & Machinery Co., Ltd.
No. 9 South Of Changjiang Road, New Zone,
Wuxi
Jiangsu Province. PRC
Tel: + 86 510 8534 2005
Fax: +86 510 8534 2001
www.wuxiteco.com

Jiangxi Teco Electric & Machinery Co., Ltd.
1328 Jinggangshan Rd., Nanchang
Jiangxi, PRC
Tel:+86 791 641 3690
Fax:+86 791 641 4228

Shanghai Office: Rm 321 Building No.6
Lane 1279 Zhongshan W. Rd.
Shanghai P.R.C
Tel: +86 21 5116 8255
Fax: +86 21 6278 8761

HONG KONG

Tecoson Industrial Development (HK) Co., Ltd.
Rm 3712 Hong Kong Plaza
186-191 Connaught Rd West, Hong Kong
Tel: +852 2858 3220

SINGAPORE

Teco Electric & Machinery (PTE) Ltd.
18 Chin Bee Drive
Singapore 619865
Tel: +65 6 265 4622
Fax: +65 6265 7354
www.teco.com.sg

JAPAN

Sankyo Co., Ltd.
26th fl. World Trading Center Bldg.
2-4-1 Hamamatsucho Minato-ku
Tokyo Japan 105-6126
Tel: +81 3 3435 9729
Fax: +81 3 3578 8381

INDONESIA

P.T. Teco Multiguna Elektro
JL Bandengan Utara No. 83/1-2-3
Jakarta Utara-14400 Indonesia
Tel: +62 21 662 2201
Fax: +62 21 6697029

MALAYSIA

STE Marketing Sdn Bhd.
Plo 52, Jalan Firma 2/1 Kawasan Perind.
Tebrau 1, 81100 Johor Bahru Johor Malaysia
Tel: +60 7 351 8862
Fax: +607 354 6107

THAILAND

Teco Electric & Machinery (Thai) Co. Ltd.
128/1 Soi Watsrivareenoi
Moo 7 Bangna-Trad Road Km 18
Bangchalong Bangplee
Samuthprakarn 10540 Thailand
Tel: +662 3371630-1

VIETNAM

TECO(Vietnam)Electric & Machinery Co., Ltd.
KCN LONG Thanh, Huyen Long Thanh, Tinh
Dong Nai.
Tel: 84-061-3514108
Fax: 84-061-3514410

AUSTRALIA

Sydney Office
Teco Australia Pty Ltd.
335-337 Woodpark Road
Smithfield NSW 2164 Australia
Tel: +61 2 9765 8118
www.teco.com.au

Melbourne Office
Teco Australia Pty Ltd.
16 Longstaff Road
Bayswater VIC 3153 Australia
Tel: +61 3 9720 4411

Brisbane Office
Teco Australia Pty. Ltd.
50 Murdoch Circuit,
Acacia Ridge QLD 4110 Australia
Tel: +61 7 3373 9600

Perth Office
Teco Australia Pty Ltd.
28 Belgravia Street,
Belmont WA 6104 Australia
Tel : +61 8 9479 4879

NEW ZEALAND

Teco New Zealand Pty Ltd.
Unit 3 / 477 Great South Road
Penrose Auckland New Zealand
Tel: +64 9 526 8480

MIDDLE EAST

Teco Middle East Electric & Machinery Co.,
Ltd.
Kingdom of Saudi Arabia Dammam City
P.O. Box 708 - Dammam 31421
Tel: +966 3 835 2619
Fax: +966 3 834 1678
www.teco-me.com

NETHERLANDS

Teco Electvic & Machinery B.V.
Teco's European Head Office
Rivium 3e Straat 27
2909 LH Capelle a/d Ijssel
Netherlands
Tel: +31 10 266 6633
Fax: +31 10 202 6415

UNITED KINGDOM

Teco Electric Europe Limited
7 Dakota Avenue, Salford. M50 2PU England
Tel: +44 161 877 8025
Fax: +44 161 877 8030
www.teco.co.uk

GERMANY

Teco Electvic & Machinery B.V.
Niederlassung Deutschland
Marktstrasse 69
37441 Bad Sachsa Germany
Tel: +49 5523 95340
Fax: +49 5523 953424
www.teco-westinghouse.de

SPAIN

Teco Electric & Machinery B.V.
Spain Office
C/Apostol Santiago, 38, 1º-1
28017 Madrid, Spain
Tel: +34 91 326 3091
Fax: +34 91 326 3091

TECO Worldwide Operations - Agents**KOREA**

Seorim Corporation
#915, Woolim Lion's Valley I,
311-3, Sangdaewon-dong,
Jungwon-gu, Seongnam-city,
Gyeonggi-do, Korea
Tel: 82-31-737-2311
Fax: 82-31-737-2312
www.seorimcorp.co.kr

PHILIPPINES

Trade One
No. 56 Aragon Street San Francisco
Del Monte 1170 Quezon City Metro Manila,
Philippines
Tel: (632) 371-3032
Fax: (632) 371-1175
www.tradeoneinc.com

TAIAN.(SUBIC)

Phase I, Subic Bay Industrial Park Argonaut
Highway Corner Brave Heart St., Subic Bay
Freeport Zone Philippines 2222.
Tel: 63-47-252-1668
Fax: 63-47-252-3234
www.taian.com.ph

SOUTH AFRICA

ArmCoil Afrika (Pty) Ltd.
Unit 3 Prestige Park 127 Main Reef Road
Technikon Roodepoort
PO Box 500 Maraisburg 1700
Gauteng South Africa
Tel: +2711 763 2351
Fax: +086 502 0086
www.armcoil.co.za

TUNISIA

AFRICA COMPANY
RUE ENNASRIA, IMM. NAFOURA BLOC
A-2-1 SFAX EL JADIDA 3027 SFAX -
TUNISIE (TUNISIA)
Tel: +216 74 40 28 85
Fax: +216 74 4028 84

SAUDI ARABIA

Al-Quraishi Electrical Services of Saudi Arabia
P.O.Box 7386-Dammam 31462
Kingdom of Saudi Arabia
Phone : +966-3-857-2537
Fax : +966-3-857-2541
www.aqesa.com

EGYPT

Automation Management Solutions
38 Mossadak Street, Dokki, Giza, Egypt
Tel: +202 333 79 774
Fax: +202 376 20 307

JORDAN

Sham Project's Solutions
P.O. Box 2001
Amman 11821-Jordan
Tel: 962-6-5526-227
Fax: 962-6-5526-228



For more information, please contact your local agent
or branch office of TECO-Westinghouse.



BRG#	d	D	B	G	Full Qty
	mm	mm	mm	grams	grams
2 SERIES					
NU205/6205	25	52	15	4	15
NU206/6206	30	62	16	5	15
NU207/6207	35	72	17	6	15
NU208/6208	40	80	18	7	20
NU209/6209	45	85	19	8	25
NU210/6210	50	90	20	9	30
NU211/6211	55	100	21	11	35
NU212/6212	60	110	22	12	40
NU213/6213	65	120	23	14	50
NU214/6214	70	125	24	15	50
NU215/6215	75	130	25	16	60
NU216/6216	80	140	26	18	60
NU217/6217	85	150	28	21	80
NU218/6218	90	160	30	24	80
NU219/6219	95	170	32	27	90
NU220/6220	100	180	34	31	100
NU221/6221	105	190	36	34	110
NU222/6222	110	200	38	38	120
NU224/6224	120	215	40	43	120
NU226/6226	130	230	40	46	140
3 SERIES					
NU305/6305	25	62	17	5	17
NU306/6306	30	72	19	7	25
NU307/6307	35	80	21	8	25
NU308/6308	40	90	23	10	30
NU309/6309	45	100	25	13	35
NU310/6310	50	110	27	15	40
NU311/6311	55	120	29	17	50
NU312/6312	60	130	31	20	60
NU313/6313	65	140	33	23	80
NU314/6314	70	150	35	26	80
NU315/6315	75	160	37	30	100
NU316/6316	80	170	39	33	100
NU317/6317	85	180	41	37	120
NU318/6318	90	190	43	41	120
NU319/6319	95	200	45	45	140
NU320/6320	100	215	47	51	160
NU321/6321	105	225	49	55	190
NU322/6322	110	240	50	60	220
NU324/6324	120	260	55	72	270
NU326/6326	130	280	58	81	300

d = Bore (mm)
D = OD (mm)
B = Width (mm)
G = Grease Qty (g)

$$G = D*B*0.005$$

Grease Type
Polyrex EM